

RCM-101

Relay Current-trip Module

The Peaktronics RCM-101 Relay Current-trip Modules are DC actuator motor controllers that shutdown the motor upon detecting an excessive motor current. Reversible DC motors, rated up to 10A locked rotor, can be easily controlled by an external circuit (such as a relay, switch, or transistor) by connecting either the OPEN or CLOSE input to the negative terminal of the battery. The unit includes on-board *open* and *close* switches, eliminating the need for an external signal during installation or servicing. The *open* input will activate the motor by applying a positive polarity to the MOTOR 1 output, while the *close* input will activate the motor with a positive polarity to the MOTOR 2 output.

The unit monitors the motor current and compares it to an adjustable trip current setting. Whenever the motor current exceeds the trip setting, the motor is shutdown from further operation - normal operation is resumed after the *open* and *close* inputs are deactivated. Since motor current is a function of the load on the motor, the trip setting is useful in protecting the actuator from excessive load conditions. The unit includes an on-board LED to indicate when the trip setting has been exceeded, and a set of form-C contacts (rated for 0.5A @ 117VAC or 1A @ 36VDC) are provided to control an external alarm or indicator.

The RCM-101B and RCM-101C units also include a 1-5mA position feedback output. By connecting a 1K ohm feedback potentiometer to the unit, the actuator position can be monitored from a remote location via the 1-5mA signal. All the units include an LED power indicator, an on-board fuse, and removable screw terminal strips (for easy servicing). The units also provide inputs for low current limit switches, eliminating the need for switching the motor current.

The RCM-101 and RCM-101B are mounted on Snaptrack®. To allow the units to be mounted directly to the actuator housing or bracket, the RCM-101A, RCM-101C, and RCM-101D are available with standoff mounts only - a mylar insulating sheet is included with these units.

Snaptrack® is a registered trademark of Augat/RDI.

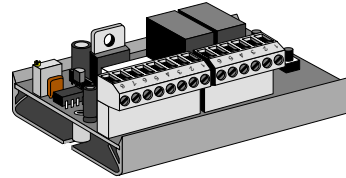

RCM-101

RCM-101A
RCM-101D

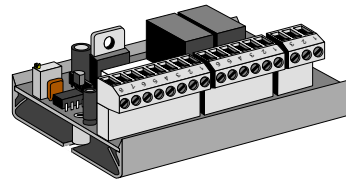
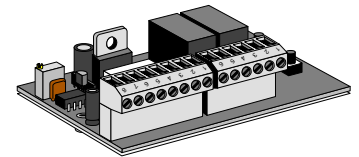

RCM-101B

RCM-101C

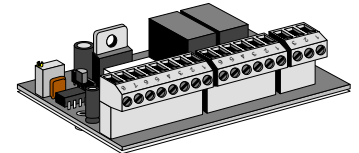

ADDITIONAL FEATURES

- Dynamic braking that minimizes motor coasting.
- Wide operating voltage of 10.25 VDC to 30 VDC.
- Low standby current (typically 23mA) when motor is not in operation.
- Non-interactive zero and span adjustments for 1-5mA output on RCM-101B and RCM-101C.
- -40 °C to 65 °C operating temperature range
- 0 to 90% relative humidity (non-condensing)

OUTLINE

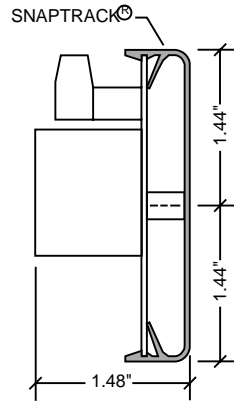
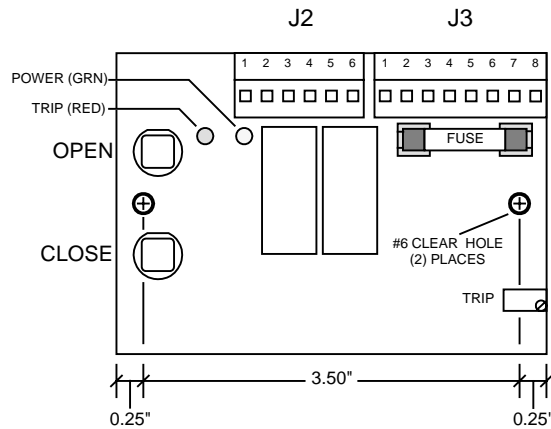

RCM-101

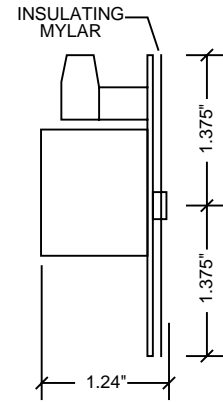

RCM-101A
RCM-101D

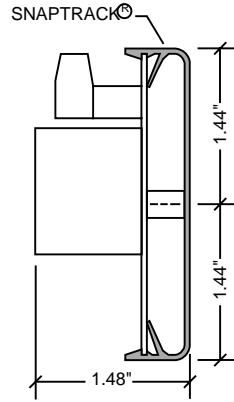
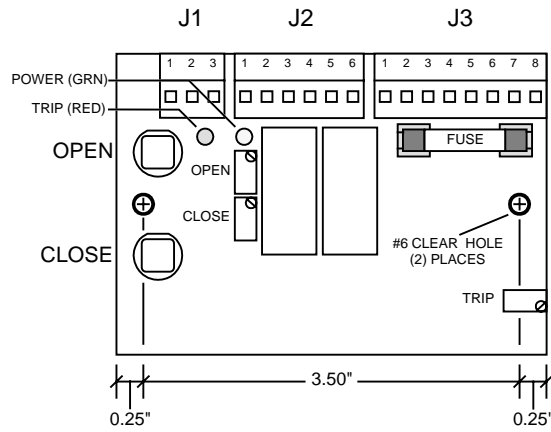

RCM-101B

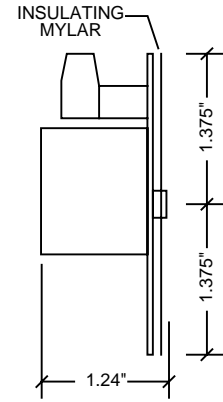

RCM-101C

ELECTRICAL CONNECTIONS

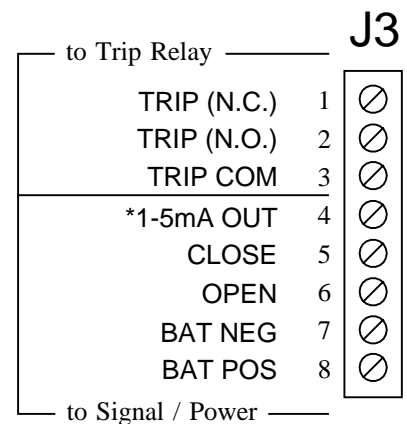
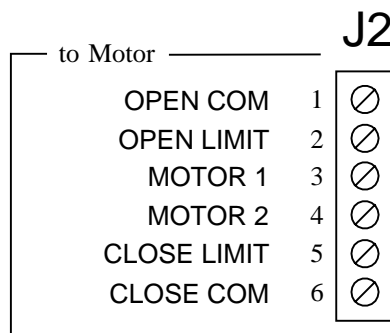
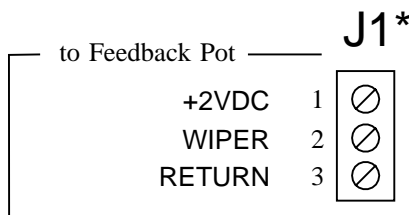

* RCM-101B and RCM-101C only.

BLOCK DIAGRAM

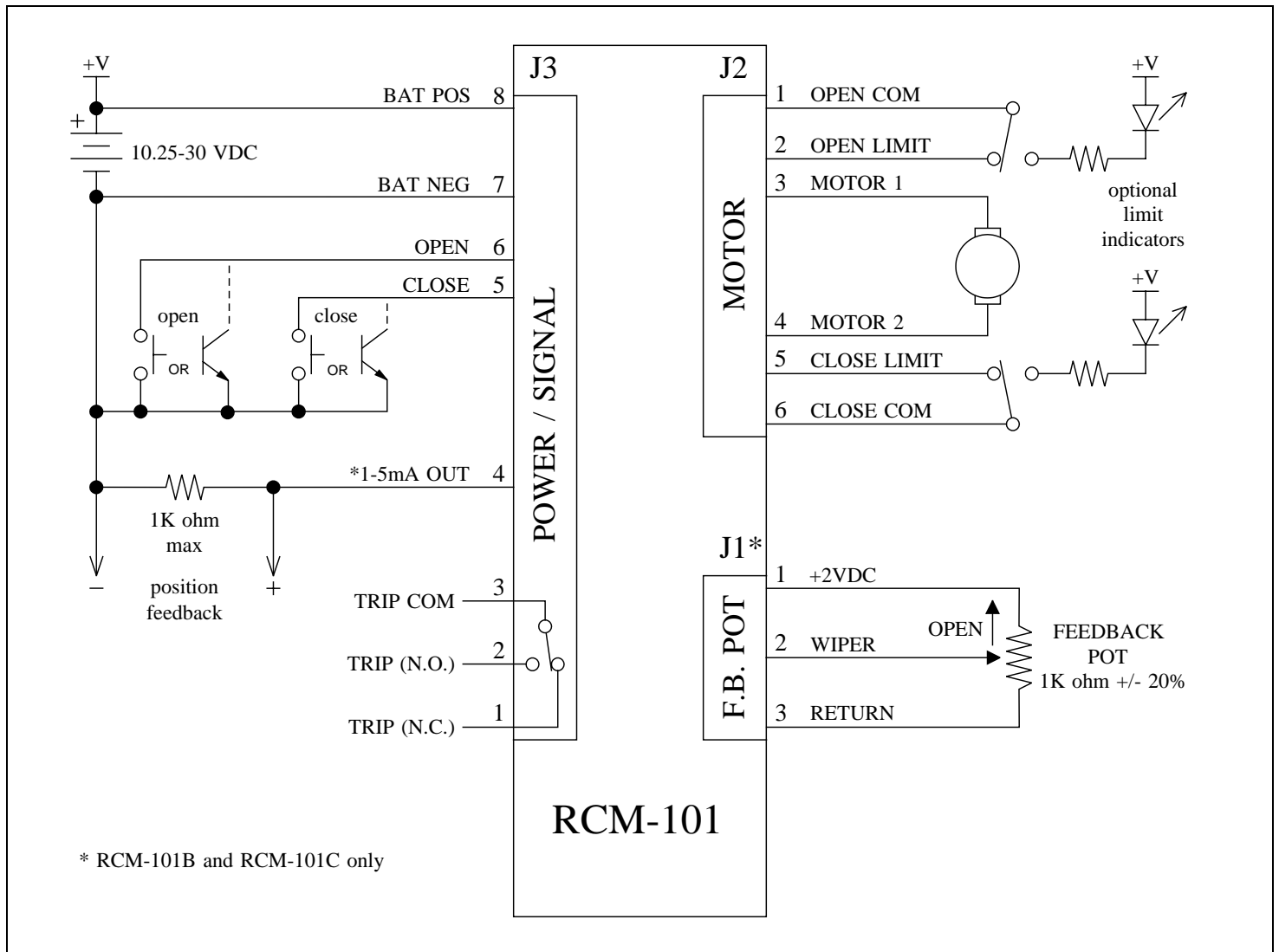

DESCRIPTION

The RCM-101 Relay Current-trip Modules come in different configurations to accommodate various applications. Basically three parameters should be considered in selecting the appropriate model: motor current trip range, position feedback, and package configuration (see Outline information).

The RCM-101D unit has a current trip setting range up to 10A. The other models have a current trip setting range up to 5A.

The RCM-101B and RCM-101C units have inputs to accept a 1K ohm position feedback potentiometer. These units provide a 1-5mA output signal that can be used to monitor the actuator position.

The RCM-101 and RCM-101B come mounted on snaptrack, while the RCM-101A, RCM-101C, and RCM-101D have standoffs for direct mounting to a bracket (insulating mylar is included).

NOTE: These units are intended for battery powered applications. Some DC power supplies may experience voltage drops during motor starts and stalls. If used, DC power supplies should be rated to handle the motor stall current.

POWER / SIGNAL (J3)

Battery power is connected to pins 7 (negative) and 8 (positive) as shown in the block diagram; the green LED power indicator will be on whenever battery power is applied. The fuse installed on the unit is a 10A time delay fuse (Littelfuse No. 314010P). The maximum current that can be safely delivered by the output is 10A. To prevent damage to the unit, replacement fuses should not exceed the 10A rating. Smaller fuse sizes can be used with smaller motors - consult the actuator manufacturer for appropriate fuse size and type.

The control inputs, pin 6 (*open*) and pin 5 (*close*), are easily driven by a relay or transistor. The input is activated by connecting the desired input to the negative battery terminal (pin 7). Each input draws only 10 mA and pulls up to a regulated 10V source.

Pins 1, 2, and 3 provide a form-C contact arrangement with pin 3 as the common terminal. During normal operation, pin 1 is normally closed and pin 2 is normally open. Upon detecting a motor current above the trip setting, pin 2 will be closed while pin 1 is opened, and the on-board red LED will be turned on to indicate the tripped condition. The unit remains in the tripped condition until it is reset by deactivating the *open* and *close* inputs. Note, the on-board *open* and *close* switches must also be deactivated to reset the unit.

The RCM-101B and RCM-101C also provide a 1-5mA output at pin 4 that represents the actuator position when a feedback potentiometer is connected to J1. Pin 4 has no internal connection on the other models.

MOTOR (J2)

The actuator motor is connected between pin 3 (MOTOR 1) and pin 4 (MOTOR 2). The motor should be wired so that the proper direction of motion coincides with the motor output polarity:

ACTIVE INPUT	MOTOR 1 J2-3	MOTOR 2 J2-4
none	NEG	NEG
<i>open</i>	POS	NEG
<i>close</i>	NEG	POS
both	POS	POS

The actuator limit switches should be wired so that the open limit switch connects pins 1 and 2 together while the close limit switch connects pins 5 and 6 together (see Block Diagram). When the actuator reaches full open, the open limit switch should disconnect pins 1 and 2; this in turn will disable the *open* input and the on-board *open*

switch. Likewise, upon reaching full closed, the close limit switch disconnects pins 5 and 6, and the *close* input and the on-board *close* switch are disabled. Pins 1 and 6 are internally connected to BAT NEG (J3-7). Note that the limit switches must be connected for normal operation.

FEEDBACK POT (J1)

The RCM-101B and RCM-101C also provide this three terminal connector for wiring a 1K ohm feedback potentiometer. When a feedback potentiometer is connected, the actuator position can be monitored from a remote location via the 1-5mA output at J3-4.

The potentiometer wiper must be connected to pin 2 of J1. One end of the potentiometer is connected to pin 1 (+2VDC), and the other is connected to pin 3 (RETURN). The potentiometer should be connected so that its resistance increases between pins 2 and 3 when the actuator moves toward open; correspondingly, the 1-5mA output will increase toward 5 mA. For best results, position the actuator to the midway point between the open and closed positions; then adjust the feedback potentiometer for approximately 1VDC (or 1/2 of the potentiometer's resistance) between pins 2 and 3 of J1.

TRIP SETTING

Adjusting the "Trip" adjustment (see Outline drawing for location) clockwise will allow higher motor currents (up to 5A, or 10A for the RCM-101D) before tripping. The trip limit can be set by applying the maximum normal load to the actuator, and then adjust the "Trip" adjustment until the unit trips.

1-5mA OUT CALIBRATION

The non-interactive adjustments for the 1-5mA output allow for easy calibration. After insuring that the feedback potentiometer and motor outputs are wired to provide a proper feedback signal, move the actuator to its full closed position (note, the feedback pot must be at 0 to 50 % of its value). Adjust the "Close" adjustment (see Outline drawing for location) to achieve 1 mA at the 1-5mA output. Then move the actuator to its full open position (note, the feedback pot must be greater than its value at close), and adjust the "Open" adjustment to achieve 5 mA at the output.