

# Wellmark Series 6900

## Cantilever liquid level control

### Application

The Cantilever Liquid Level Control Series offers design simplicity, easy installation, adjustment, and reliable liquid level monitoring. It is a highly efficient device for the control of liquid level in oil and gas production equipment such as: separators, dehydrators, and treaters, as well as in manufacturing plants, hazardous waste disposal, food processing, water treatment, petro-chemical facilities, or wherever fluid levels need to be monitored or controlled. The sensing element design, with no moving parts exposed to the tank or vessel fluid, makes the simple installation of the control possible in various standard pipe closures such as: ANSI flanges and grooved, or union, connections. The sensing element has a selection of three control head options that control pneumatic supply to control valves, alarm systems, pressure switches, solenoids, and relays, all of which may be used in response to liquid level changes. These control options are:

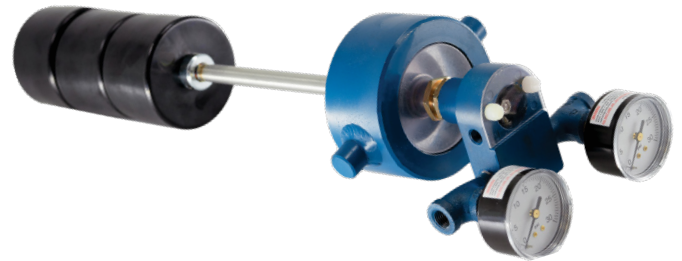

**Snap action**



**Throttling**

### Throttling

This throttling control head assembly provides a proportional output pressure signal as changes in vessel liquid levels are sensed by the displacers and transmitted by the sensing rod. Constant vessel liquid level can be maintained when the control outlet is connected with a properly sized pneumatic, diaphragm activated control valve. Sensing adjustment is controlled by an external adjusting screw.

### Snap action

The snap action control head assembly provides on/off supply pressure at a specific liquid level set point established by the displacer setting. This on/off signal can be used to power pressure switches, start-up or shut-down controls, alarms, or pneumatic diaphragm activated control valves to open or close system flow lines.

### Features

- Industry Standard
- Design Simplicity
- Optional Pilot Head
- Throttle or Snap Acting
- Optional Process Connections – See Chart
- Optional Choice of Sensing Rod– See Chart
- Optional Choice of Displacer – See Chart
- Optional Low-Bleed MIZER®– See Chart

### Specifications

Max. Working Pressure . . . . .	1500 psi
Operating Temperature . . . . .	-20°F or +200°F (higher temperature available)
Process Connections . . . . .	See Chart
Pilot Connections . . . . .	1/4" FNPT
Supply Pressure . . . . .	20 psi Minimum-30 psi Maximum (limited by pressure gauge)
Output Pressure . . . . .	3-15 psi – Throttle 0-Full Supply– Snap (Pilot good to 75 psi)

### Materials

Displacer . . . . .	See Chart
Process Connection . . . . .	Carbon Steel
Sight Glass . . . . .	Polycarbonate
Sensing Rod . . . . .	316 S.S.
Seals . . . . .	Buna-N Standard (others available)
Hammer Union Ring . . . . .	4" and 5" WCB Others Fabricated Carbon Steel

### WARNING

If supply gas is flammable or noxious, this product **MUST** be located in a well ventilated non-hazardous area or sealed and vented to a non-hazardous area.

# Series 6900

---

## Principle of Operation

This liquid level control operates on the basis of two basic physical laws:

1. "A solid, heavier than a fluid (a displacer/s) will, if placed in it, descend to the bottom of the fluid, and the solid will, when weighed in the fluid, be lighter than its true weight by the weight of the fluid displaced."  
–Archimedes' Principal
2. A Cantilever beam (sensing rod) projecting outward, anchored at one end, will flex in proportion to the weight applied, or removed, at the free end.

Therefore, following Archimedes' Principal, a body (displacer or float) immersed in a fluid experiences a buoyant, or lift force equal to the weight of the displaced fluid. This static lift force acts vertically through the center of gravity of the displaced volume.

Applying the above fundamentals to this liquid level control, we can sense and regulate levels of most gas to fluid interface applications as well as many fluid to fluid interfaces.

By attaching a displacer to the free end of the sensing rod, vertical movement is achieved. The rising and lowering of the fluid gives the static lift force—either up or down, which is transferred along the rod to an actuator pad extending out past the anchored end. As the actuator pad moves to the nozzle, supply pressure is diverted to output, opening a diaphragm-operated motor valve. As fluid is drained, and fluid level declines, the actuator pad moves away from the nozzle and supply pressure is relieved from the diaphragm operated motor valve, and valve closes, allowing the cycle to repeat.

In a throttling mode, this procedure will continually throttle the valve to maintain the fluid level at a desired set point.

In a snap-acting mode, a shuttle pilot is attached to the throttling head converting the throttling output pressure to pilot signal pressure, tripping the shuttle pilot to either full supply pressure, opening valve quickly, or to zero supply pressure, allowing valve to close.

## Installation

Before installing this control, inspect the unit for any shipment damage or any foreign material. Visually observe that the actuator pad and rod-end are centered in the sensing rod connector. If not, the unit has been distorted and should be returned to center before placing the control in service.

Check for mechanical clearance of displacer for free movement by flicking the actuator pad after installation of the unit. If vibration is observed, unit is free to work as intended.

Connect suitable supply gas line to the 1/4" FNPT connection stamped "IN". 20 to 30 psi is recommended for proper operation (Filtered gas or air is strongly recommended for better and longer maintenance-free operation.)

Connect "output" port, stamped "OUT" to unit to be controlled.

## Start-up procedure

Energize the control by opening the supply gas to pilot head (20 to 30 psi recommended).

Adjust the nozzle upward toward the actuator pad, by loosening nozzle lock nut and turning nozzle clockwise, until output pressure gauge starts to indicate a reading (1-3 psi).

Observing the fluid level through the level glasses for desired level, adjust the nozzle up or down to actuate the diaphragm-operated motor valve when desired level is obtained. When satisfactory fluid level is obtained, tighten nozzle lock nut to secure setting.

Observe several cycles to assure that the system is properly functioning.

**NOTE:** To increase fluid level set-point, adjust the nozzle counterclockwise away from the actuator pad. To decrease fluid level setpoint, adjust nozzle counter-clockwise toward actuator pad.

Normal pilot installation is direct acting, rise in fluid level resulting in an increase of output. For indirect acting, rise in fluid level resulting in a decrease of output, simply loosen 3/4 -16 jam nut behind pilot head, and rotate pilot head 180° and retighten 3/4 -16 jam nut.

# Model codes

Chart 1: Determining the model code



**A CONNECTION SIZE OPTIONS**

Code	Size	Available Connections
2	2"	Screwed, Flanged
3	3"	Hammer Union only
4	4"	Hammer Union, Flanged, Grooved
5	5"	Hammer Union only

Note: 3" and 5" sizes not available with Flanged connections

**B TYPE OF CONTROL**

Code	Type
C	Cantilever

**C TYPE OF CONNECTION**

Code	Style
F	Flanged (Specify Rating)
G	Grooved
S	Screwed Bushing (2" Sizes only)
U	Hammer Union STD Thd. – Blind Flange
SU	Hammer Union STD Thd. – Sight Glass
SUA	Hammer Union ACME Thd. – Sight Glass

**D PILOT HEAD**

Code	Type
LC	Pneumatic Throttling
RLC	Pneumatic Snap
LMZ	Mizer Throttling Action
RMZ	Mizer Snap Action

**E ROD ASSEMBLY TYPE**

Code	Size Type	Length
A	Short (Dumpy)	8-3/16"
M	Medium	12-3/8"
L	Long Straight	19"

**F PRESSURE RATING BY CONNECTION**

Code	Connection Type	ANSI Class	Max Pressure
1	Flanged	150#	285 PSIG @ 100F
2	Flanged	300#	740 PSIG @ 100F
6	Flanged	600#	1480 PSIG @ 100F
0	Other Connections	-	1500 PSIG @ 100F

**G DISPLACERS**

Code	Size	Material	Type
1	2" x 10"	Delrin®	Screw-on
2	2" x 12"	Delrin®	Screw-on
3	2" x 10"	Phenolic	Screw-on
4	2" x 12"	Phenolic	Screw-on
5	2.5" x 8"	Delrin®	Screw-on
7	2.5" x 8"	Delrin®	Slide-on
8	3.25" x 2.75"	Phenolic	Slide-on
9	3.25" x 2.75"	Phenolic	Slide-on
0	2.75" x 10"	PVC	Screw-on
X	Other Options (Consult Factory)		

# Model codes

## Cantilever displacers

Displacer Size	Material	Part No.	Max. Temp. Continuous
2" DIA. X 10" SCREW-ON	DELRIN®	1123146	200
2" DIA. X 12" SCREW-ON	DELRIN®	1126093	200
2" DIA. X 10" SCREW-ON	PHENOLIC	1125674	275
2" DIA. X 12" SCREW-ON	PHENOLIC	1119060	275
2 ½" DIA. X 8" SCREW-ON	DELRIN®	1120155	200
2 ½" O.D. X 8" SLIDE-ON	DELRIN®	1124006	200
3 ¼" O.D. X 2 ¼" SLIDE-ON*	PHENOLIC	1126242	400
2 ¾" DIA. X 10" SCREW-ON**	PVC	1123178	165

\*3 Displacers Required for Liquid Gas Interface

\*4 Displacers Required for Liquid Liquid Interface

\*\*2 ¾" x 10" Displacer Applicable for Either Liquid Gas or Liquid Liquid Interface



**Delrin® & phenolic screw-on displacers  
(medium and short rods)**

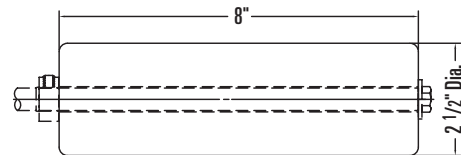

**Delrin® slide-on displacers  
(long straight rod only)**

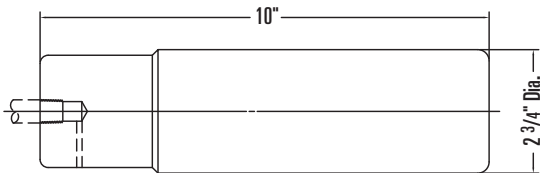

**Pvc screw-on displacer  
(medium and short rods)**

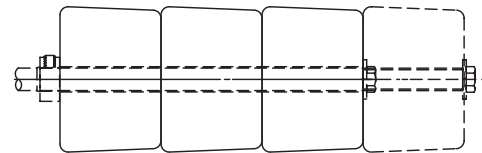

**Phenolic slide-on displacers (long str. & Offset rod)  
3 Req'd liquid-gas interface  
4 req'd liquid-liquid interface**

# Parts list

## Parts list for cantilever snap acting pilot head

Item	Description	Qty.	Part No.
1	PILOT HOUSING, ALUM. ALLOY 383	1	1125144
2	STREET "L", MALLEABLE	2	1123001
3	PRESSURE GAUGE	2	1121596
4	ADJUSTING SCREW, 303 S.S.	1	1122112
5	NOZZLE, 303 S.S.	1	1123122
6	O-RING, NITRILE	2	1040267
7	JAM NUT, 18-8 S.S.	1	1117799
8	O-RING, NITRILE	1	1117796
9	COVER PLATE, POLYCARBONATE	1	1121506
10	COVER SCREW, NYLON	2	1119982
11	O-RING, NITRILE	2	1156179
12	BOOSTER BODY, ALUMINUM	1	1122596
13	COVER, ALUMINUM	1	1119307
14	LOWER SEAT, ALUMINUM	1	1121558
15	UPPER SEAT, ALUMINUM	1	1126355
16	CONNECTOR, ALUMINUM	1	1122595
17	SCREW, STEEL PLATED	1	1124234
18	SPRING, ASTM A-313	1	1124573
19	DIAPHRAGM, FAIRPRENE	1	1126243
20	GASKET, FAIRPRENE	1	1125280
21	FILLSTER HD. SCREW, STEEL	4	1125137
22*	DAMPNER, STAINLESS STEEL	1	1122588

\*Not shown

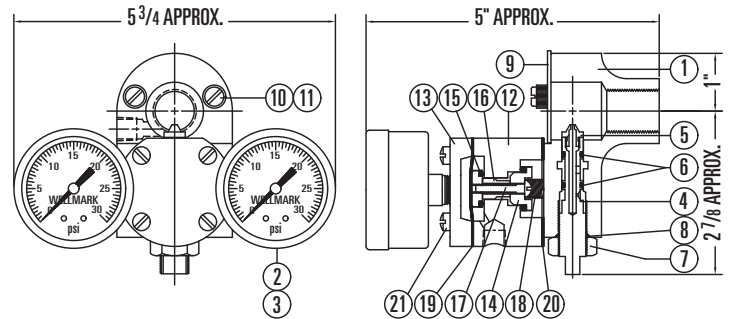

## Parts list for cantilever throttling pilot head

Item	Description	Qty.	Part No.
1	PILOT HOUSING, ALUM. ALLOY 383	1	1121551
2	STREET TEE, MALLEABLE	2	1125628
3	PRESSURE GAUGE	2	1121596
4	ADJUSTING SCREW, 303 S.S.	1	1122112
5	NOZZLE, 303 S.S.	1	1123122
6	O-RING, NITRILE	2	1040267
7	JAM NUT, 18-8 S.S.	1	1117799
8	O-RING, NITRILE	1	1117796
9	COVER PLATE, POLYCARBONATE	1	1121506
10	COVER SCREW, NYLON	2	1119982
11	O-RING, NITRILE	2	1156179

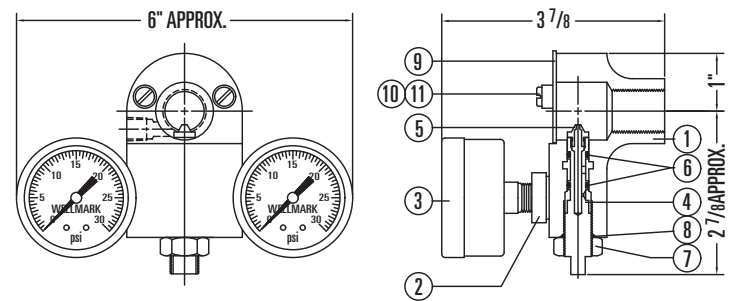

# Cantilever rods and additional components

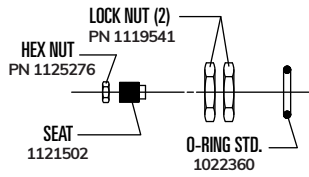

**Additional components  
for all rods**

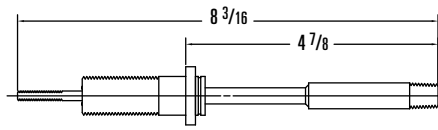

**Short rod assembly**

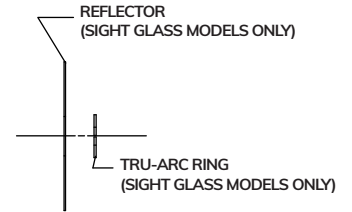

**Additional components  
for all rods**

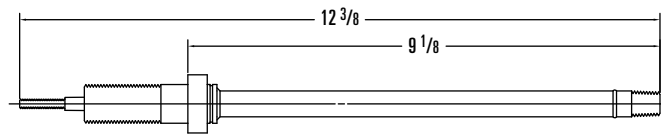

**Medium rod assembly**

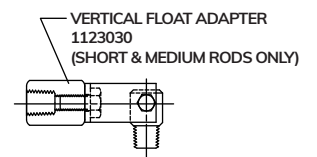

**VERTICAL FLOAT ADAPTER  
1123030  
(SHORT & MEDIUM RODS ONLY)**

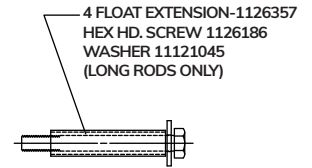

**4 FLOAT EXTENSION-1126357  
HEX HD. SCREW 1126186  
WASHER 11121045  
(LONG RODS ONLY)**

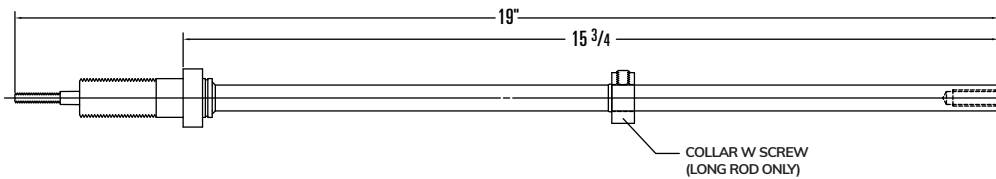

**Long rod assembly**

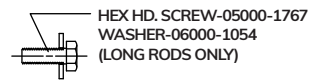

**HEX HD. SCREW-05000-1767  
WASHER-06000-1054  
(LONG RODS ONLY)**

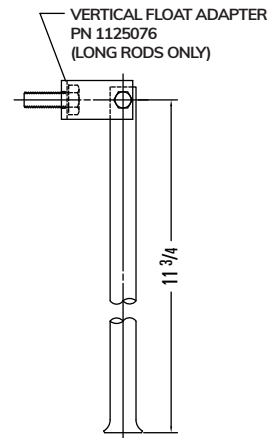

**VERTICAL FLOAT ADAPTER  
PN 1125076  
(LONG RODS ONLY)**

# Typical assembly

**WARNING**  
 If supply gas is flammable or noxious, this product MUST be located in a well ventilated non-hazardous area or sealed and vented to a non-hazardous area.

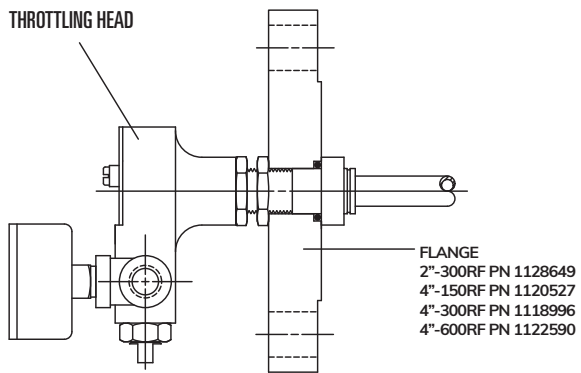
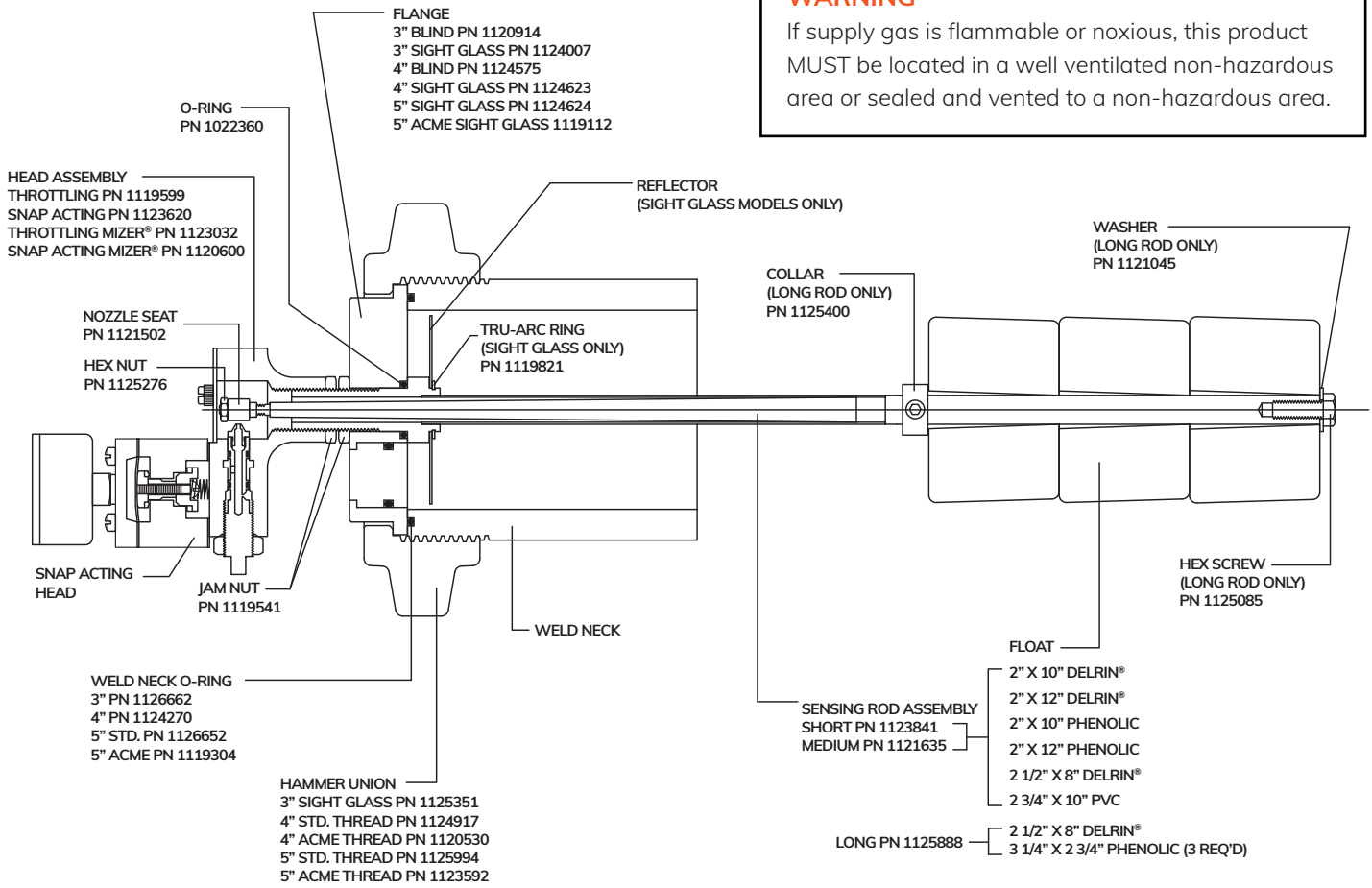

ANSI raised face flanges  
 2" And 4"

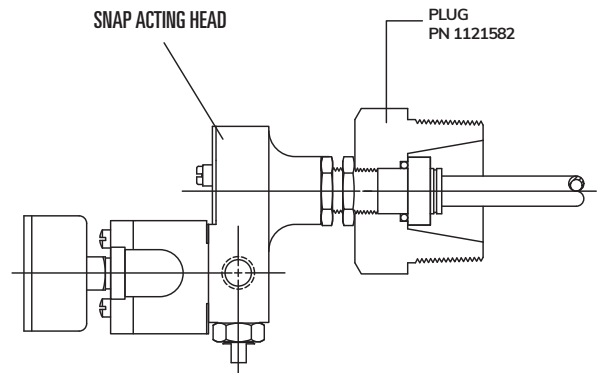

2" MNPT plug

---

## Why you can depend on genuine Norriseal-Wellmark products

- In-house engineering and technical support
- In-depth applications experience
- Award-winning innovation and ongoing product development
- ISO 9001 certified manufacturing
- Over five decades of industry service
- Compliance with all industry standards and specifications
- Responsive service and prompt delivery
- Field support available worldwide

Contact Norriseal-Wellmark for more information about our products and services.

### Texas

Houston . . . . . 713-466-3552

### Oklahoma

Oklahoma City . . . . . 405-672-6660

### Louisiana

Broussard . . . . . 337-837-3223



Follow us on LinkedIn.

### Request for Quote

NRS\_RFQ@championx.com



[NorrisealWellmark.com](https://NorrisealWellmark.com)

---

**Norriseal-Wellmark** | 11122 W Little York Rd | Houston, TX 77041

This document is provided on an "as is" basis without warranties of any kind. Norriseal-Wellmark DISCLAIMS ALL WARRANTIES, EXPRESS OR IMPLIED, INCLUDING, BUT NOT LIMITED TO, IMPLIED WARRANTIES OF MERCHANTABILITY, FITNESS FOR A PARTICULAR PURPOSE OR SUITABILITY FOR ANY PURPOSE, TITLE, AND NON-INFRINGEMENT. While reasonable care has been taken in the preparation of this document, Norriseal-Wellmark does not represent or warrant that the contents of this document are accurate, complete, reliable, current or error-free.