

# Norriseal Series 2200 and 2220 Control Valves

Space-saving solution: Yokeless design fits tight separator and scrubber applications



Norriseal Series 2200 and 2220 control valves have been the standard for controlling fluids in the oil and gas industry since 1966. The hammer nut entry into the valve body allows quick access for trim inspection. Both the 2200 and 2220 valves can be furnished with a variety of trims and end connections (see table 5 on page 3 and table 7 on page 4).

The 2200 has an open yoke which allows for the mounting of positioners, limit switches and other devices. It is also used in applications that require an exposed stem for accurate travel indication. The yoke allows the valve to be used for higher temperature ranges.

The 2220 is the close-coupled or yokeless, space saving version of the 2200. This series is ideal for controlling liquids on compressor scrubbers and housed production separators where space is at a premium.

## Features

- Patented spherical plug and matching seat gives precision seating alignment
- Two types of throttling trim for precision control: modified percentage and equal percentage

- Hammer nut has extra thread engagement on the valve body to release any pressure within the body and allow safe removal of the bonnet/actuator during disassembly
- Integral flange is provided on the bonnet to secure the hammer nut/bonnet to the valve body, improving safety when used in a corrosive atmosphere
- Carbide, Stellite and soft seats are available for corrosion and high/low temperatures; other materials are available for NACE applications

## Body styles and dimensions

### Globe, “T” styles and angle bodies

The 1.00-inch comes in two styles: globe and T-body, allowing fluid to flow straight through the body in a globe pattern or angle flow pattern by repositioning the pipe plug (which comes in the bottom port) and replacing it in the upper port. Norriseal popularized the T-body in 1950 and it still is the most popular style in the industry.

The 2.00-inch body comes in two styles, globe and angle.

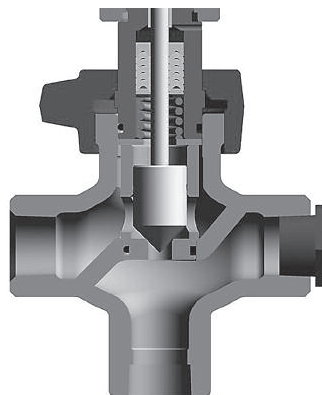

1.00-inch T-body plug for angle flow with quick opening carbide trim.

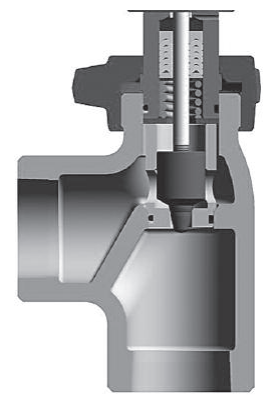

2.00-inch angle body with equal percentage 17-4 PH SST trim.

# Body styles and dimensions

TABLE 1: VALVE DIMENSIONS														
Body Size		Connection Type	Face to Face "F"										"G"	
			ANSI Rating											
			150		300		600		900/1500		2500			
inches/mm		inches	mm	inches	mm	inches	mm	inches	mm	inches	mm	inches	mm	
1.00	25	NPT**	-	-	-	-	-	-	6.25	159	6.25	159	4.88	124
		RF	7.25	184	7.25	197	8.25	210	9.38	238	11.38	289		
		RTJ	7.75	197	8.25	210	8.25	210	9.38	238	11.38	289		
2.00	50	NPT**	-	-	-	-	-	-	7.50	191	7.50	191		
		RF	10.00	254	10.50	267	11.25	286	12.88	327	16.25	413		
		RTJ	10.50	267	11.13	283	11.38	289	13.00	330	16.48	418		

\* Angle 2.00" screwed body not shown. "F" dimension = "F"/2.  
 \*\* Standard NPT body is rated to ANSI 1500.

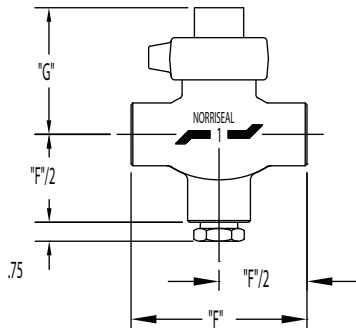

1.00" NPT Connection

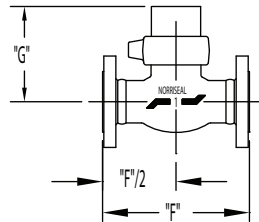

1.00" Globe Body

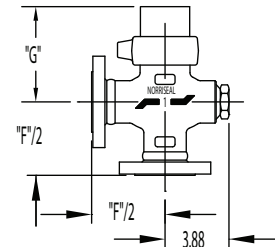

1.00" "T" Body  
(configured for angle flow)

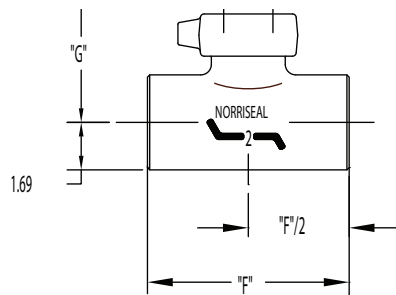

2.00" NPT Connection

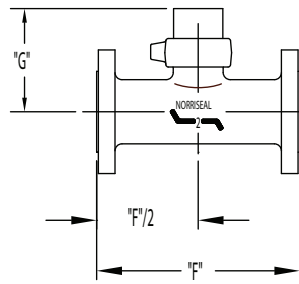

2.00" Globe Body

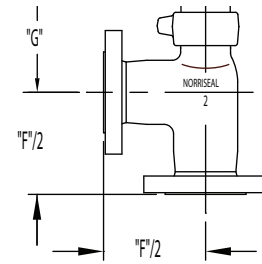

2.00" Angle Body

# Specifications

**TABLE 2: MATERIALS OF CONSTRUCTION**

Valve Component	Options	
<b>Body</b>	ASTM A216 Gr. WCC ASTM A351 Gr. CF8M	ASTM A352 Gr. LCC
<b>Bonnet</b>	ASTM A696/C	316 SST
<b>Hammer Nut</b>	ASTM A105 ASTM A350 Gr. LF2	316 SST
<b>Stem</b>	Nitronic 50	
<b>Packing</b>	TFE V Ring Viton / TFE	Fabric V Ring
<b>Packing Spring</b>	316 SST	Inconel X750
<b>Packing Washer</b>	CSTL	17- 4 PH
<b>Packing Retainer</b>	17- 4 PH	
<b>O-Ring Wetted</b>	Nitrile Aflas	Viton HSN
<b>Diaphragm</b>	Buna / Nylon	Neoprene / Nylon
<b>O-Ring Non Wetted</b>	Viton	HSN
<b>Actuator Spring</b>	Steel	
<b>Adjust. Screw</b>	CSTL / PLtd.	316 SST
<b>Diaphragm Housing</b>	CSTL	
<b>Diaphragm Plate</b>	CSTL	
<b>Travel Indicator</b>	303 SST	
Actuator pressure connection size – 1/4" – 18 NPT thread		

**TABLE 3: OPERATING TEMPERATURE\***

<b>2200/2220</b>	Std. WCC Mtl.	-20 to 180°F (-29 to 82°C)
<b>2200/2220</b>	Std. LCC Mtl.	-40 to 180°F (-40 to 82°C)
<b>2200</b>	Opt. Mtl.	-50 to 400°F (-45 to 204°C)
<b>2200</b>	Opt. Mtl.	-50 to 300°F (-45 to 149°C)

\* Optional seal material built valves can cover high or low temperature ranges, but not necessarily both.

**AVAILABLE ACCESSORIES TO MOUNT**

- Positioners (electro-pneumatic, pneumatic and digital)
- Limit switches
- Solenoid valve
- Filter regulators
- I/P transducers
- Pressure controllers

**TABLE 4: ACTUATOR**

Actuator Number	Maximum W. P.		Size/Eff. Area		Travel	
	psig	bar	sq. ins	cm. sq.	ins.	mm
9	55	3.8	35	226	0.625	15.9
12	55	3.8	70	452	0.625	15.9

**TABLE 5: BODY END CONNECTIONS AND PRESSURE RATINGS\***

Body Size		Pressure Rating		NPT	ASME Flanged RF and RTJ				Body Style
					150/300	600	900/1500	2500	
Inches/mm		psig	bar						
1.00	25	3750	259	X	X	X	X	Globe/"T"	
1.00	25	6250	431	X			X	"T"	
2.00	50	3750	259	X	X	X	X	Globe/Angle	
2.00**	50	6000	414	X			X	Globe/Angle	

\* Pressure ratings are based on temperatures of -20 to 100° F (-29 to 38° C) with standard material. Consult factory for pressure ratings for temperatures other than those shown.

(X) indicates end connections  
\*\* 2" 2500# is not available in CF8M available.

# Valve trim

**TABLE 6: FLOW COEFFICIENT (CV) VALUES - UNBALANCED PLUG CONTROL TRIMS**

Body Size		Trim Size		Modified Percentage Trim (Flow Up)										Quick Open Trim (Flow Down)
				% Valve Opening - % of Travel										100
inches	mm	inches	mm	10	20	30	40	50	60	70	80	90	100	100
1.00	25	0.25	6.4	.284	.506	.657	.767	.875	.989	1.10	1.20	1.32	1.43	1.68
1.00	25	0.38	9.5	.311	.621	.942	1.28	1.64	2.07	2.51	2.93	3.35	3.70	3.82
1.00	25	0.50	12.7	.557	1.11	1.68	2.26	2.92	3.62	4.30	4.98	5.43	5.60	5.60
1.00	25	0.75	19.1	.752	1.57	2.43	3.42	4.58	6.08	7.93	9.71	10.6	11.0	11.6
1.00	25	1.00	25.4	.983	2.01	3.40	6.12	8.90	11.7	13.5	14.4	15.1	15.4	15.4
2.00	50	0.25	6.4	.284	.506	.657	.767	.875	.989	1.10	1.20	1.32	1.43	1.68
2.00	50	0.38	9.5	.311	.621	.942	1.28	1.64	2.07	2.51	2.93	3.35	3.70	3.75
2.00	50	0.50	12.7	.592	1.17	1.76	2.34	2.95	3.70	4.57	5.50	5.95	6.08	6.08
2.00	50	0.75	19.1	.882	1.76	2.76	3.82	5.05	6.57	8.49	10.8	12.2	12.9	13.0
2.00	50	1.00	25.4	1.01	2.02	3.58	6.45	9.38	12.32	13.7	15.4	16.7	17.1	18.0
2.00	50	1.25	31.8	N/A										20.6

\*Consult factory for equal percentage trim  $C_v$  values.

**TABLE 7: PLUG TYPES AND SIZES**

Size		Quick Opening	Modified Percentage	Equal Percentage
inches	mm			
0.19	4.7	-	-	X
0.25	6.4	X	X	X
0.38	9.4	X	X	X
0.50	12.7	X	X	X
0.75	19.1	X	X	-
1.00	25.4	X	-	-
1.25	31.75	X	-	-

Note: (X) indicates sizes available

**TABLE 8: PLUG MATERIAL**

Standard	Optional
17- 4 SST	316 SST
	Carbide
	Stellite 6/316SS
	UHMW 3/4" and 1" only

**FIG. 9:**  
1.00" 2220 Valve

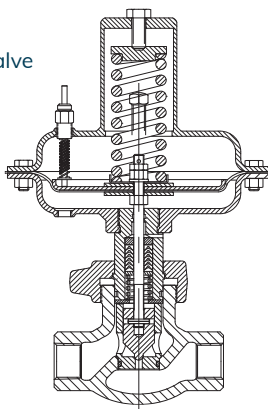

**FIG. 10:**  
1.00" 2200 Valve with a no. 9 direct (spring opening) actuator. Throttle trim, flow up.

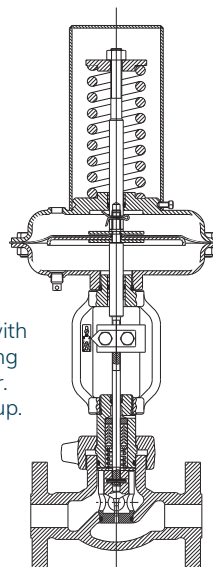

**FIG. 11:**  
Hammer nut / bonnet body engagement

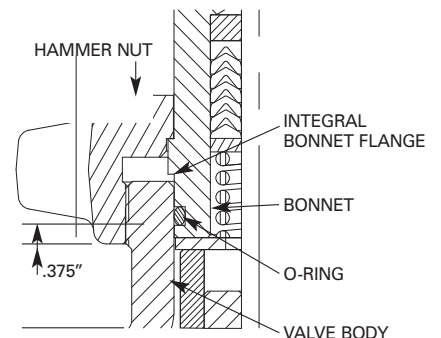

# Valve trim continued

**TABLE 9: MAXIMUM DIFFERENTIAL PRESSURE (3-15 PSI)**

Trim Size		Actuator Size	Gas Supply Pressure		Flow Under Seat				Flow Over Seat			
					Throttle				Quick Opening			
					Direct		Reverse		Direct		Reverse	
inches	mm	Number	psig	bar	psig	bar	psig	bar	psig	bar	psig	bar
.25	6.4	9	20	1.4	2610	180	4750	327	6250	431	6250	431
			30	2.0	6250	431	6250	431	6250	431	6250	431
		12	20	1.4	6250	431	6250	431	6250	431	6250	431
			30	2.0	6250	431	6250	431	6250	431	6250	431
.38	9.5	9	20	1.4	1050	72	1975	136	6250	431	6250	431
			30	2.0	4220	291	5150	355	6250	431	6250	431
		12	20	1.4	3695	255	5550	383	6250	431	6250	431
			30	2.0	6250	431	6250	431	6250	431	6250	431
.50	12.7	9	20	1.4	530	36	1050	672	6250	431	6250	431
			30	2.0	2315	160	2850	197	6250	431	6250	431
		12	20	1.4	2015	139	3060	211	6250	431	6250	431
			30	2.0	5580	385	6250	431	6250	431	6250	431
.75	19.1	9	20	1.4	180	12	420	29	2400	166	1700	117
			30	2.0	975	67	1210	83	3460	239	1700	117
		12	20	1.4	840	58	1315	91	4520	312	2975	205
			30	2.0	2415	167	2900	200	6250	431	6250	431
1.00	25.4	9	20	1.4	70	5	205	14	1215	84	780	54
			30	2.0	515	35	650	45	1730	119	780	54
		12	20	1.4	440	30	710	49	2255	155	175	12
			30	2.0	1330	92	1600	110	3290	227	2330	161

**TABLE 10: MAXIMUM DIFFERENTIAL PRESSURE (6-30 PSI)**

Trim Size		Actuator Size	Gas Supply Pressure		Flow Under Seat				Flow Over Seat			
					Throttle				Quick Opening			
					Direct		Reverse		Direct		Reverse	
inches	mm	Number	psig	bar	psig	bar	psig	bar	psig	bar	psig	bar
.25	6.4	9	33	2.3			6250	431	6250	431		
		12			6250	431	6250	431	6250	431	6250	431
.38	9.5	9	33	2.3			3300	228	6250	431		
		12			3955	273	5855	404	6250	431	6250	431
.50	12.7	9	33	2.3			1804	124	6250	431		
		12			2165	149	3200	221	6250	431	6250	431
.75	19.1	9	33	2.3			751	52	3165	218		
		12			905	62	1210	83	6250	431	285	20
1.00	25.4	9	33	2.3			393	27	1525	105		
		12			480	33	745	51	3600	248	175	12

# Actuators

TABLE 11: SPRING DESCRIPTION			
Actuator Number	Spring Rate	Range	Table No.
9	AA	3 – 11 psi	9
	HA	6 – 30 psi	10
12	HA	3 – 15 psi	9
	WM	6 – 30 psi	10

TABLE 12: SHUTOFF CLASSIFICATION	
<b>Metal Seats</b>	ANSI Class IV (ANSI/FCI 70-2-1998) Leakage less than 0.01% of maximum valve capacity
<b>Soft Seats</b>	ANSI Class VI (ANSI/FCI 70-2-1998) Leakage less than one bubble per minute. (3/4" and 1" only)

TABLE 13: ACTUATOR DIMENSIONS															
Body Size		Actuator Number	Spring Description	A		B								Direct* Spring Cover	
				Actuator Diameter		Reverse				Direct					
				inches	mm	2200		2220		2200		2220			
inches	mm			inches	mm	inches	mm	inches	mm	inches	mm	inches	mm	inches	mm
1.00	25	9	AA	9.5	241	15.38	391	9.75	248	15.88	403	10.25	260	5.50	140
2.00	50		HA			17.13	435	11.50	292	17.38	441	11.75	298	7.00	178
1.00	25	12	HA	12.5	318	16.50	419	10.88	276	17.38	441	11.75	298	7.00	178
2.00	50		WM			20.25	514	14.62	371	20.50	521	14.38	365	10.00	254

\*Clearance required for "Direct Actuator" cover removal.

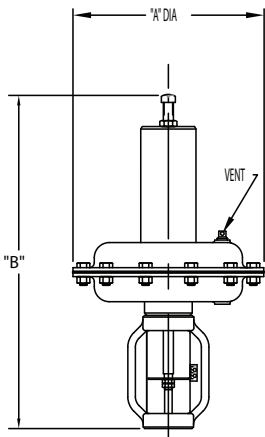

**FIG. 12:**  
Reverse Actuator

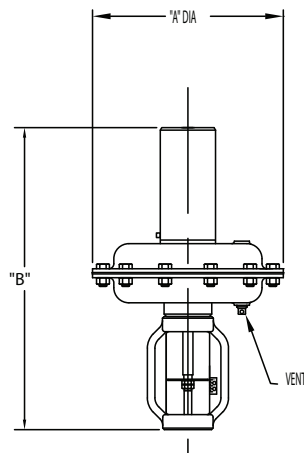

**FIG. 13:**  
Direct Actuator

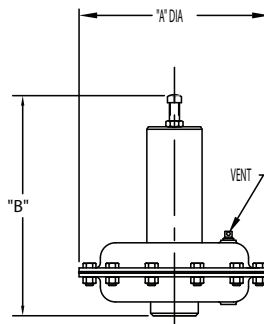

**FIG. 14:**  
Reverse Actuator

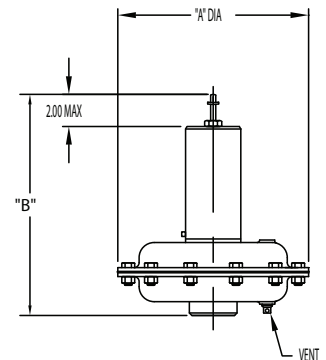

**FIG. 15:**  
Direct Actuator

# Model code

## 10-2220S-36TGA-9AA 0.38AQCARB



**A**

BODY SIZE	
Code	Size (Inches)
1	1
2	2
2.06	2.06"
2.56	2.56"

\*Sizes used with API Conn RTJ only.

**B**

VALVE SERIES	
Code	Series
2200	Open Yoke
2220	Close Coupled

For electric actuated valve, use 2200 open yoke

**C**

BODY END CONNECTIONS	
Code	Type
RF	Flanged Raised Face
RJ	Flanged Ring Type Joint
S	Threaded - NPT Female
AJ	API Conn (RTJ)

**D**

SPECIAL COMPONENTS	
Code	Body/Bonnet Material
-	WCC/A696
N <sup>(1)</sup>	WCC/A696
P <sup>(1)</sup>	LCC/A350 LF2
Q	LCC/A350 LF2
S <sup>(1)</sup>	CF8M/316

(1) Suitable for NACE

**E**

BODY RATING	
Code	Working Pressure Class
02	ANSI 150
07	ANSI 300
14	ANSI 600
21	ANSI 900
36	ANSI 1500
50	API 5000*
60	ANSI 2500*

\*Ratings only available in 4B/A487 carbon steel material.

**F**

ACTUATOR ACTION	
Code	Type
T	Pneumatic Reverse Acting (Fail Closed)
B	Pneumatic Direct Acting (Fail Open)
E	Electric (Fail in Last Position)

**G**

BODY STYLE	
Code	Type
A <sup>(2)</sup>	Angle
G	Globe
T <sup>(3)</sup>	"T"

(2) 2" only (3) 1" only

**H**

SEAL MATERIAL		
Code	Diaphragm	Wetted O-ring
A	Buna	Low Temp. Buna
M	Viton	Low Temp. Buna
V <sup>(1)</sup>	Buna	Viton
Q <sup>(1)</sup>	Viton	Viton
S <sup>(1)</sup>	Buna	Aflas
N <sup>(1)</sup>	Buna	Low Temp. Buna

(1) Suitable for NACE.  
Select w/ NACE Packing option below

**I**

PACKING		
Code	Material	Packing Temp.
-	PTFE V-Ring	-120°+400°F - 84°+204°C
C	Fabric V-Ring	-20°+250°F - 28°+121°C
N <sup>(1)</sup>	PTFE V-Ring	-120°+400°F - 84°+204°C
L <sup>(1)</sup>	Viton/PTFE	-15°+400°F - 26°+204°C

(1) Suitable for NACE

**J**

ACTUATOR SELECTION	
Code	Type
9	Pneumatic Size #9
12	Pneumatic Size #12
EX	Electric - Exlar
AS	Electric - Asahi
US	Electric - USI SmartStep

**K**

ACTUATOR SPRINGS	
Code	Input Signal
AA, HA	#9 (3-15PSI), #9 (6-30PSI)
HA, WM	#12 (3-15PSI), #12 (6-30PSI)
OO	Modulating (4-20mA), On-Off (0-10VDC)

**L**

TRIM ORIFICE SIZE	
Code	Nominal Size
0.19	3/16"
0.25	1/4"
0.38	3/8"
0.50	1/2"
0.62	5/8"
0.75	3/4"
1.00	1"
1.25	1-1/4"

Note: 1" Series 2200/2220 is limited to 1.00" maximum trim size.  
\*Size only available in quick open "BQ" trim.

**M**

TRIM GEOMETRY & CHARACTERISTIC			
Code	Seating Geometry	Trim Characteristic	Trim
AE	Angular	Equal % (0.19 only)	Steel or Stellite
AP	Angular	Modified %	Carbide
AQ	Angular	Quick Open	
BE	Spherical	Equal %	Steel or Stellite
BP	Spherical	Modified %	
BQ	Spherical	Quick Open	

Note: • Tungsten-carbide and soft-seated trims are available ONLY with angular seating geometry.  
• For equal % trim use code "AE" for 3/16" & code "BE" for 1/4", 3/8", 1/2" and 3/4" sizes.

**N**

TRIM MATERIAL					
Code	Plug or Butt Material	Plug Insert Material	Seat or Seat/Cage Material	Seat Insert Material	Temp. (°F)
17-4	17-4 SST	-	17-4 SST	-	-100 to +400
316	316 SST	-	316 SST	-	-100 to +400
STL6	STL6/316	-	STL6/316	-	-100 to +400
CARB	316 SST	Carbide	316 SST	Carbide	-50 to +400
UHMW	316 SST	Polyethylene	316 SST	-	-20 to +180

Note: Soft trim, UHMW, is limited to trim sizes 3/4" and 1".

# Why you can depend on genuine Norriseal-Wellmark products

- In-house engineering and technical support
- In-depth applications experience
- Award-winning innovation and ongoing product development
- ISO 9001 certified manufacturing
- Over five decades of industry service
- Compliance with all industry standards and specifications
- Responsive service and prompt delivery
- Field support available worldwide

Contact Norriseal-Wellmark for more information about our products and services.

### Texas

Houston . . . . . 713-466-3552

### Oklahoma

Oklahoma City . . . . . 405-672-6660

### Louisiana

Broussard . . . . . 337-837-3223



Follow us on LinkedIn.

### Request for Quote

NRS\_RFQ@championx.com



NorrisealWellmark.com

Norriseal-Wellmark | 11122 W Little York Rd | Houston, TX 77041

This document is provided on an "as is" basis without warranties of any kind. Norriseal-Wellmark DISCLAIMS ALL WARRANTIES, EXPRESS OR IMPLIED, INCLUDING, BUT NOT LIMITED TO, IMPLIED WARRANTIES OF MERCHANTABILITY, FITNESS FOR A PARTICULAR PURPOSE OR SUITABILITY FOR ANY PURPOSE, TITLE, AND NON-INFRINGEMENT. While reasonable care has been taken in the preparation of this document, Norriseal-Wellmark does not represent or warrant that the contents of this document are accurate, complete, reliable, current or error-free.