

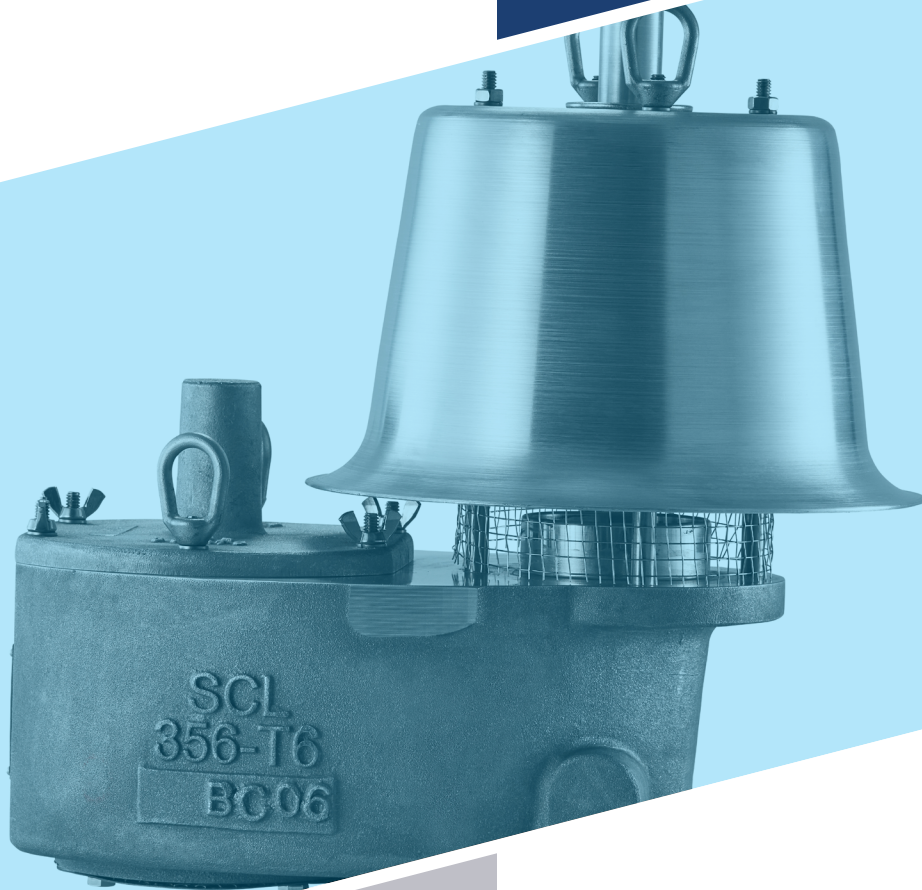

PRESSURE/VACUUM RELIEF VALVE

MODEL 12E-TWW-0



MODEL 12E-TWW-0

The Groth Model 12E-TWW-0 design was created to exceed industry needs. Extensive research and development have produced a product that achieve both superior sealing performance and industry leading flow rates, while also allowing customers to reach required flow with a potentially smaller sized valve possibly replace with and utilizes 10% overpressure design to achieve full-lift flow. The pressure vacuum relief valve is designed to protect your tank from damage created by overpressure or excessive vacuum. Costly product evaporative losses due to normal tank “breathing” are greatly reduced. The Model 12E-TWW-0 are superior sealing valves developed to minimize fugitive emissions while providing increased protection and safety to tank equipment and on-site personnel.

Technical Details

- Size: 2” through 6”
- Casting Material: Aluminum, Carbon Steel, Stainless Steel
- Pallet Material: Aluminum, Stainless Steel
- Diaphragm Materials: Buna-N, Blue FKM or FEP
- Weight Material: Zinc-Plated Steel, Stainless Steel
- Bolting Class: 150# ASME, PN10, PN16, JIS drilling classes available
- Available Pressure Settings: 0.5 osig to 24 osig
- Available Vacuum Settings: 0.464 osig to 24 osig
- Superior tightness, exceeding API-2000 leak requirements
- PED and ATEX Certified

Features

- This valve is designed to work at 10% overpressure
- Product leakage and fugitive emissions are reduced via ultra-tight sealing
- Higher flow capacity to protect from both excessive pressure and excessive vacuum build up
- Peripheral and central seat guides ensure reliable, repeatable performance
- Designed for easy maintenance, thus reducing downtime and operational cost

Options

- Corrosion resistance can be enhanced with FKM soft goods



SPECIFICATIONS

Connection Size Inches (mm)	A Width Inches (mm)	B Height Inches (mm)	C Depth Inches (mm)	ASSEMBLY WEIGHT *SS LBS (KG)
2 (50)	15.54 (395)	14.25 (362)	11.15 (283)	47.6 (21.6)
3 (75)	19.74 (501)	16.75 (425)	13.15 (334)	74.6 (33.8)
4 (100)	22.45 (570)	18.13 (461)	15.15 (385)	103.5 (46.9)
6 (150)	32.45 (824)	24.00 (610)	21.00 (533)	199.4 (90.5)

*without spacers weight provided

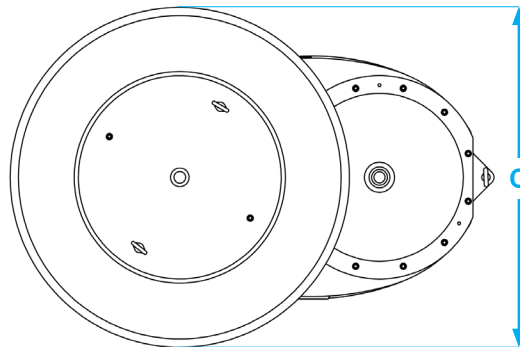
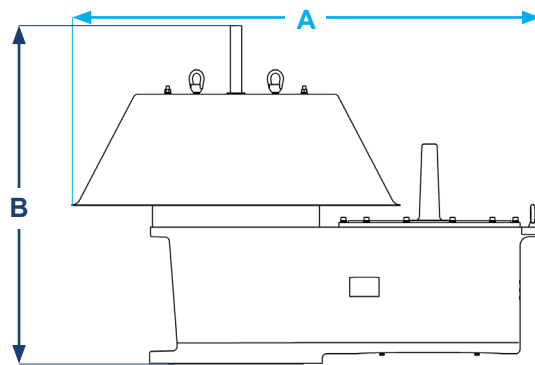

FLOW CAPACITY

Model: 12E-TWW-0 Pressure Flow Capacity

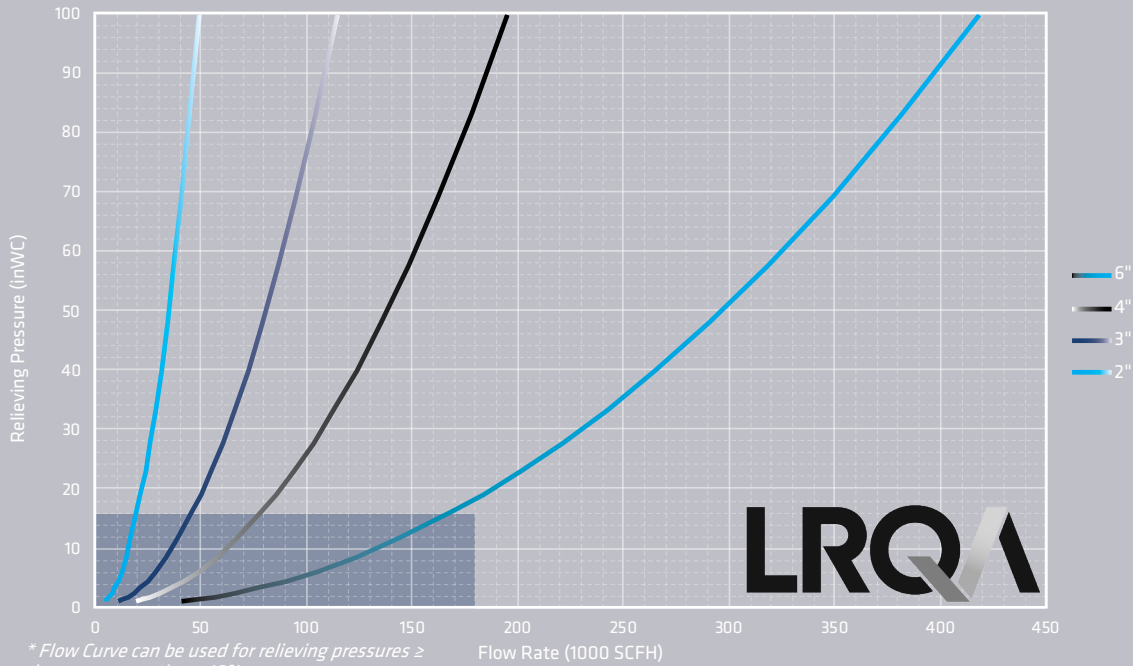

LRQA

Model: 12E-TWW-0 Pressure Flow Capacity

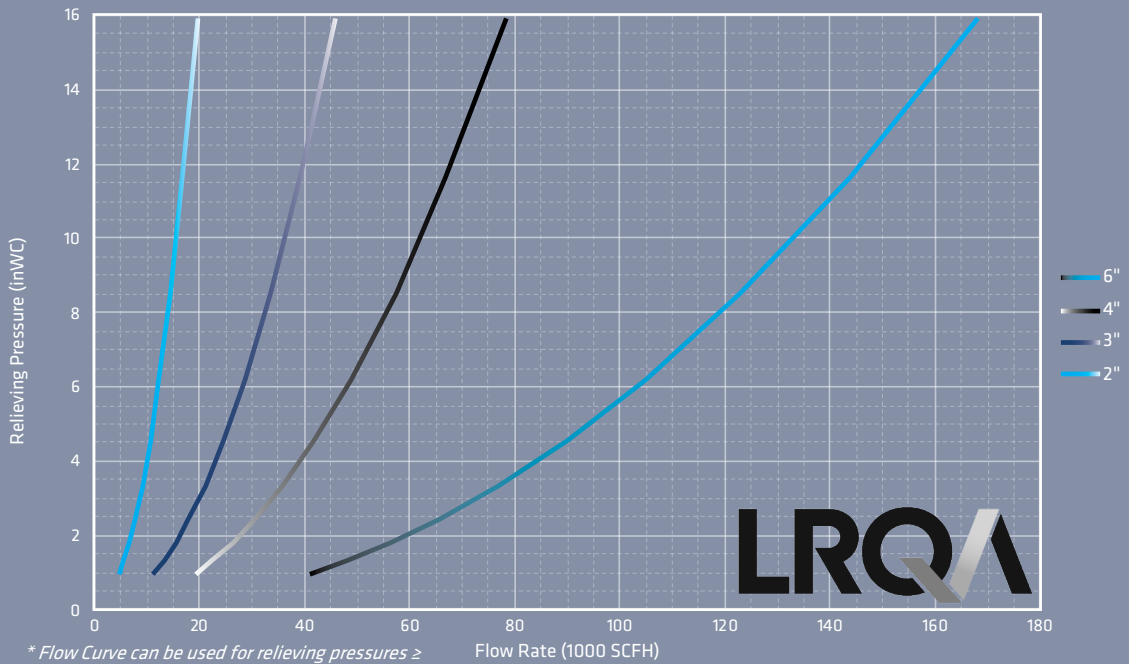

LRQA

- The test equipment, procedures, and reporting methods utilized by Groth Corporation meet the requirements of standards API 2000/ISO 28300. The equipment, methods, and results have been reviewed and certified by Lloyds.
- Flow data are for tank mounting or end-of-line and includes entrance loss, exit loss and internal losses.
- Flow values based on air at 60°F venting to atmospheric pressure of 14.6959 psia.

FLOW CAPACITY

Model: 12E-TWW-0 Pressure Flow Capacity

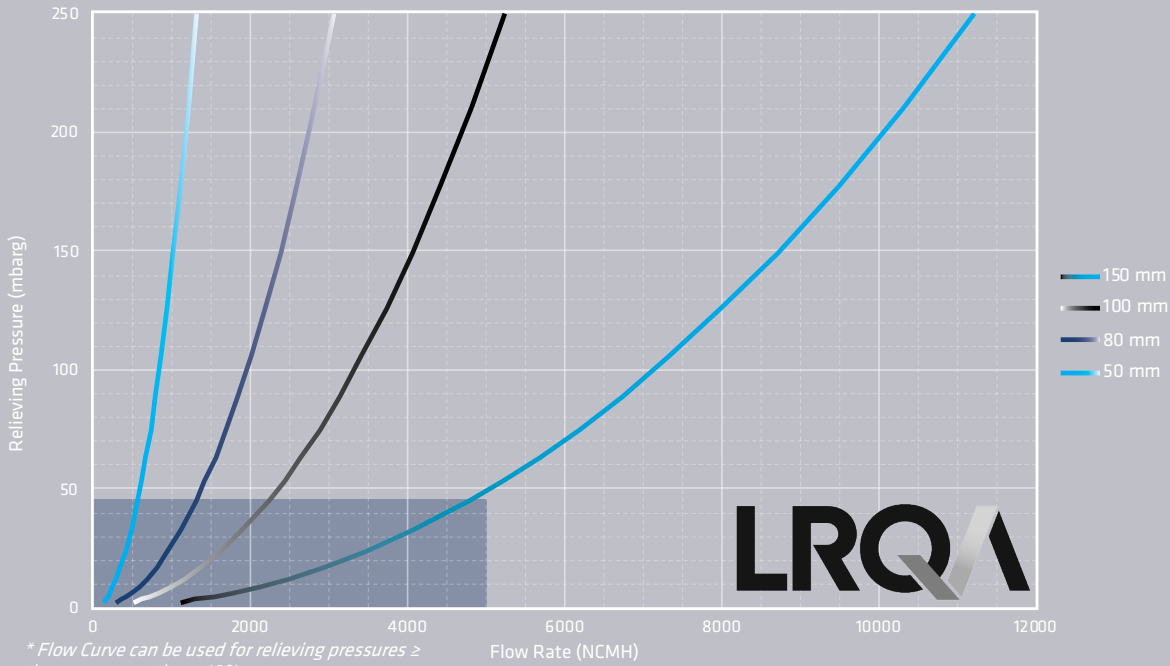

* Flow Curve can be used for relieving pressures \geq the pressure setting + 10%

Flow Rate (NCMH)

LRQA

Model: 12E-TWW-0 Pressure Flow Capacity

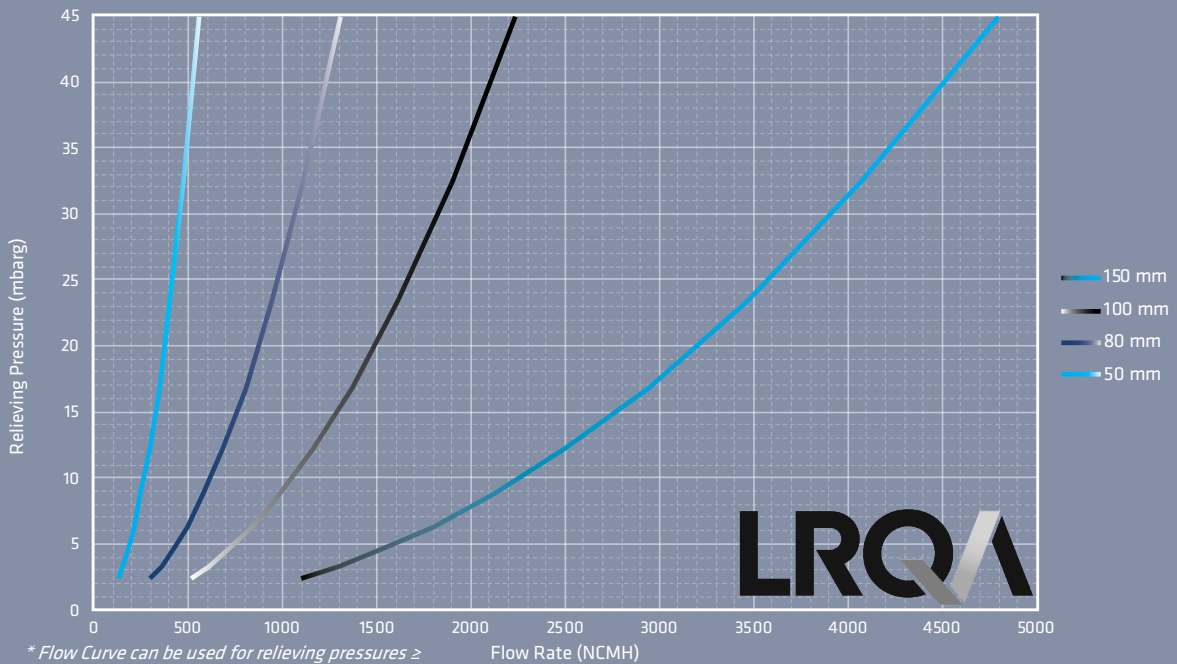

* Flow Curve can be used for relieving pressures \geq the pressure setting + 10%

Flow Rate (NCMH)

LRQA

- The test equipment, procedures, and reporting methods utilized by Groth Corporation meet the requirements of standards API 2000/ISO 28300. The equipment, methods, and results have been reviewed and certified by Lloyds.
- Flow data are for tank mounting or end-of-line and includes entrance loss, exit loss and internal losses.
- Flow values based on air at 0°C venting to atmospheric pressure of 1.01325 bara.

FLOW CAPACITY

Model: 12E-TWW-0 Pressure Flow Capacity

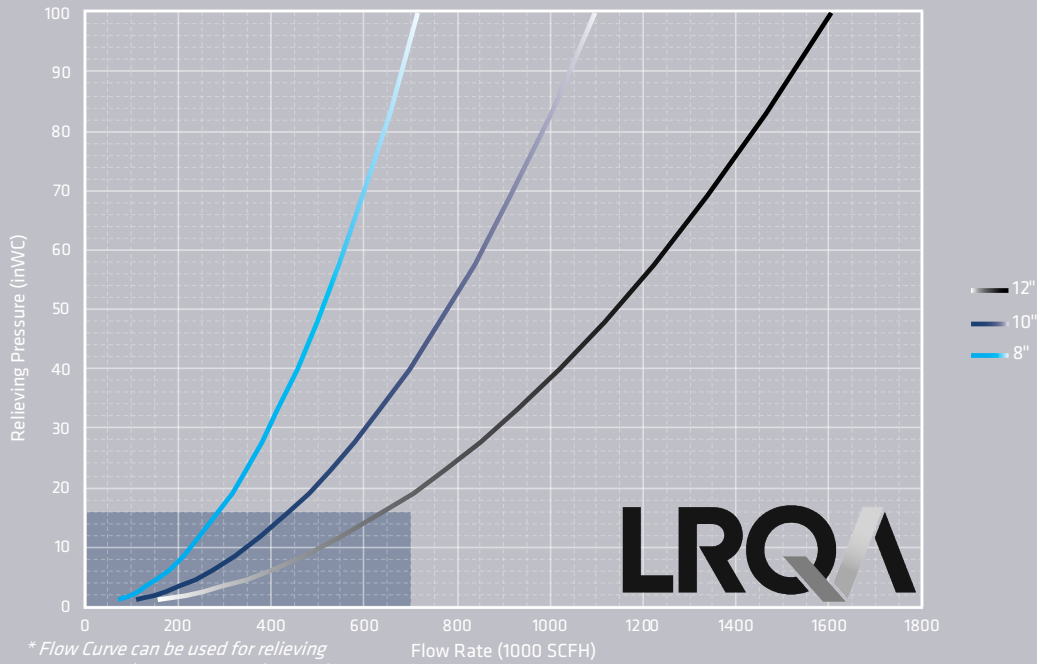

Model: 12E-TWW-0 Pressure Flow Capacity

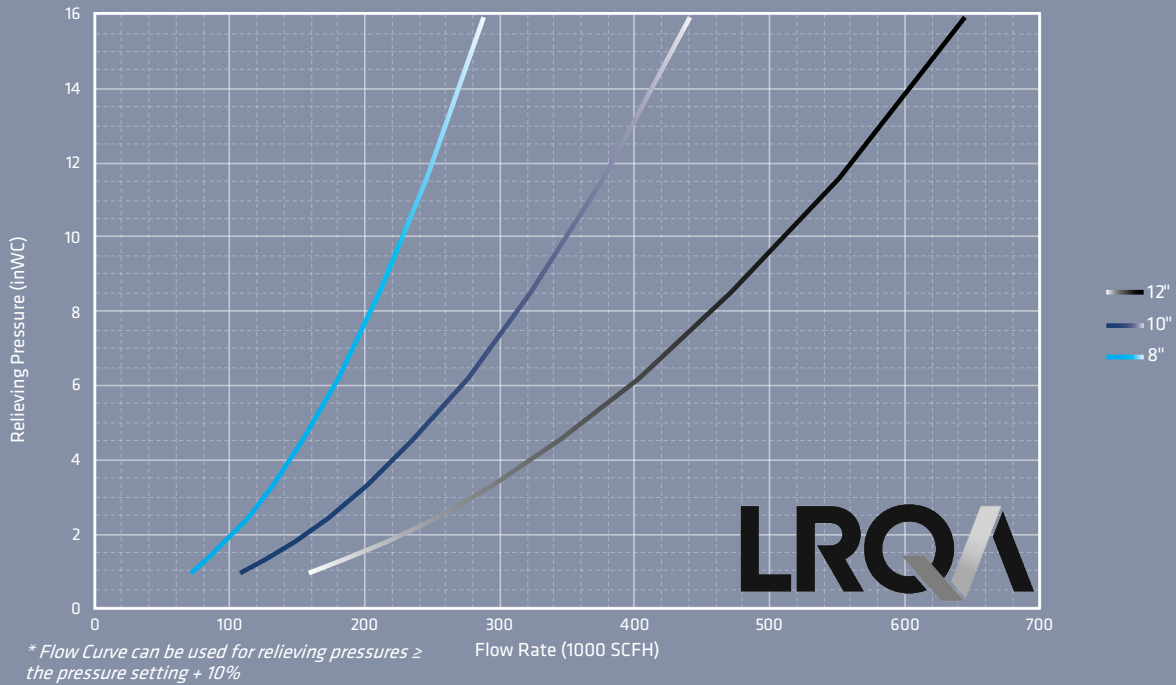

- The test equipment, procedures, and reporting methods utilized by Groth Corporation meet the requirements of standards API 2000/ISO 28300. The equipment, methods, and results have been reviewed and certified by Lloyds.
- Flow data are for tank mounting or end-of-line and includes entrance loss, exit loss and internal losses.
- Flow values based on air at 60°F venting to atmospheric pressure of 14.6959 psia.

FLOW CAPACITY

Model: 12E-TWW-0 Pressure Flow Capacity

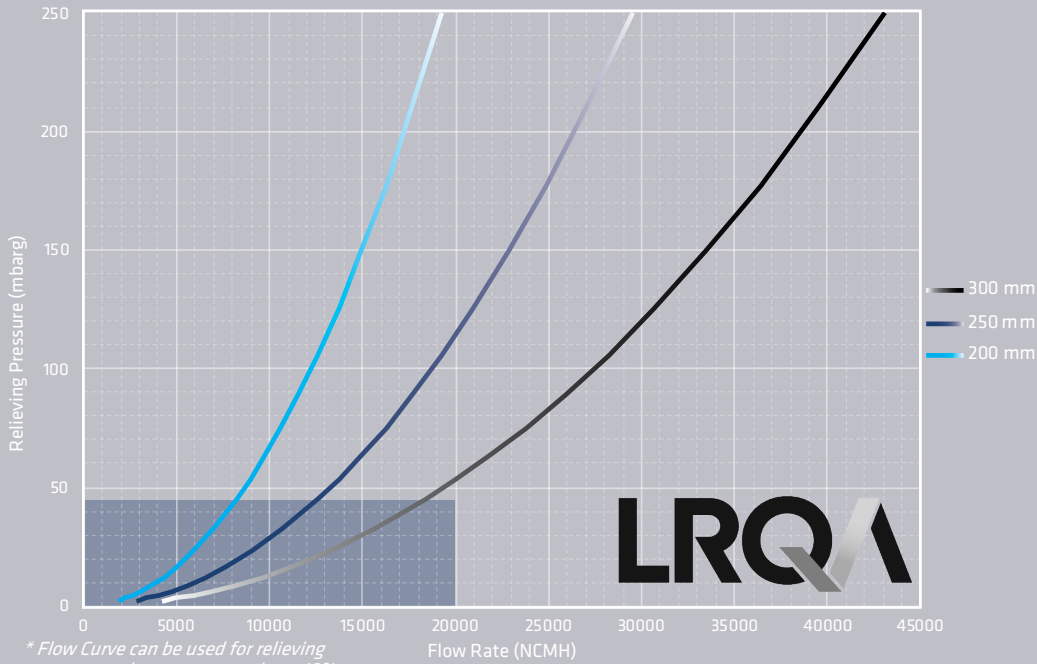

* Flow Curve can be used for relieving pressures \geq the pressure setting + 10%

Model: 12E-TWW-0 Pressure Flow Capacity

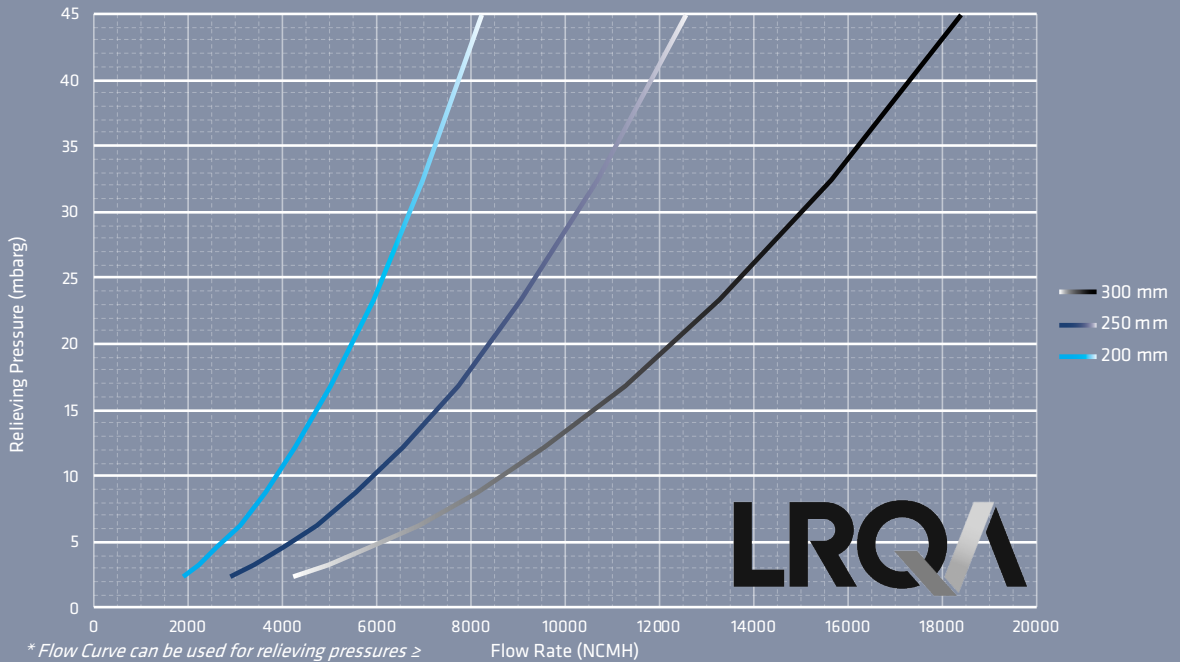

* Flow Curve can be used for relieving pressures \geq the pressure setting + 10%

- The test equipment, procedures, and reporting methods utilized by Groth Corporation meet the requirements of standards API 2000/ISO 28300. The equipment, methods, and results have been reviewed and certified by Lloyds.
- Flow data are for tank mounting or end-of-line and includes entrance loss, exit loss and internal losses.
- Flow values based on air at 0°C venting to atmospheric pressure of 1.01325 bara.

FLOW CAPACITY

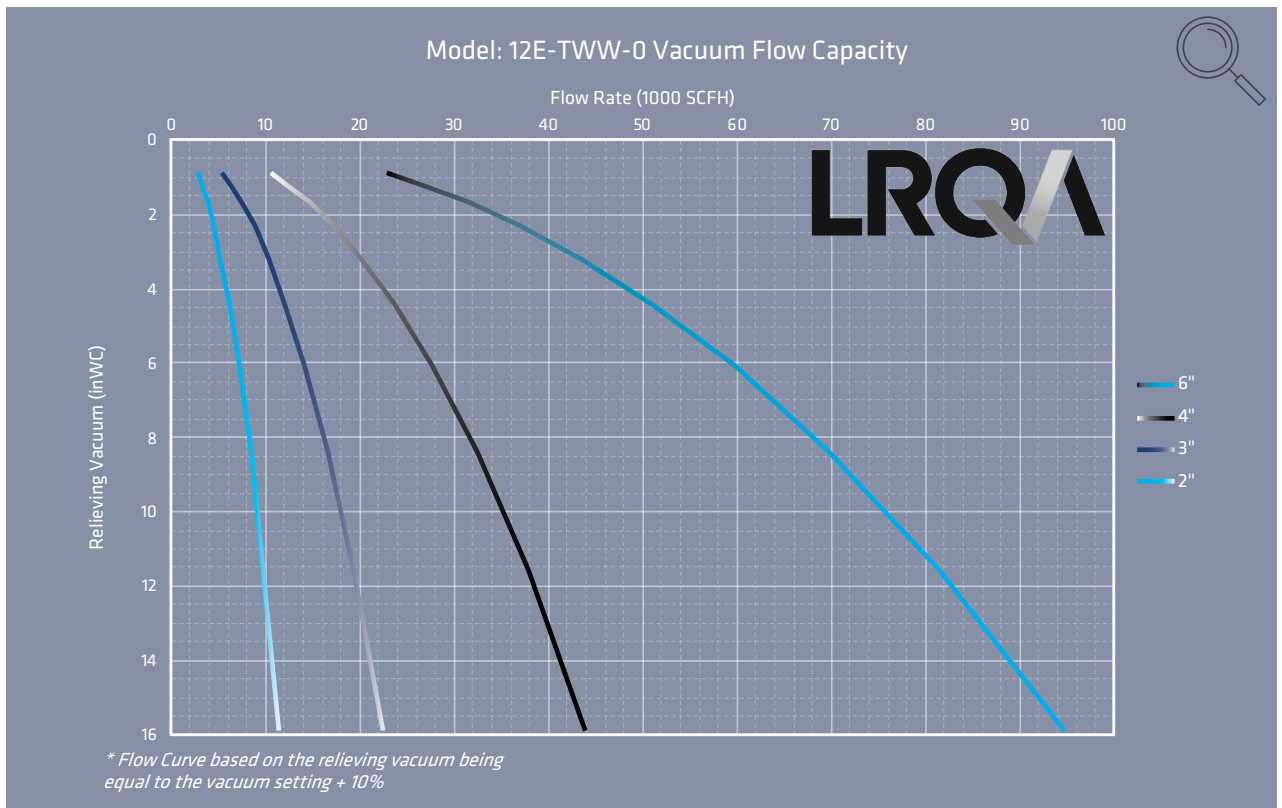
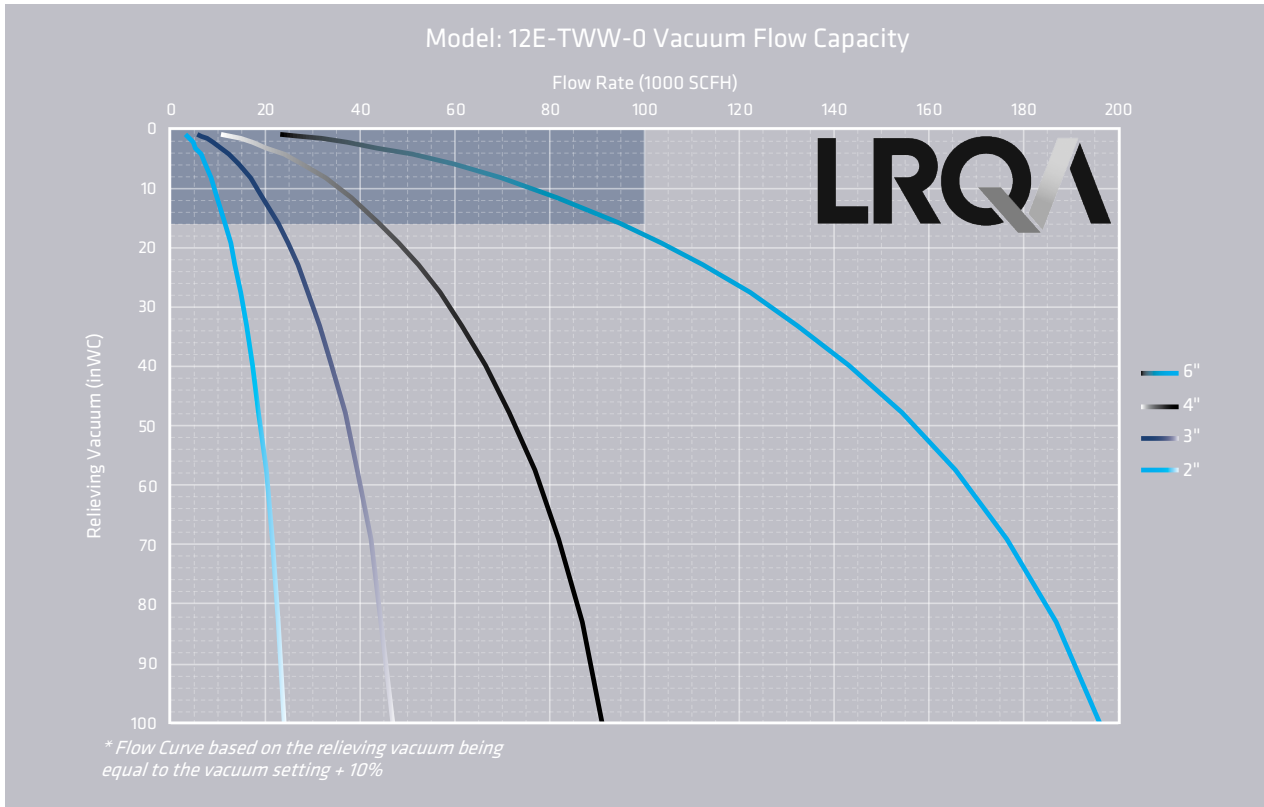

- The test equipment, procedures, and reporting methods utilized by Groth Corporation meet the requirements of standards API 2000/ISO 28300. The equipment, methods, and results have been reviewed and certified by Lloyds.
- Flow data are for tank mounting or end-of-line and includes entrance loss, exit loss and internal losses.
- Flow values based on air at 60°F venting from atmospheric pressure of 14.6959 psia.

FLOW CAPACITY

Model: 12E-TWW-0 Vacuum Flow Capacity

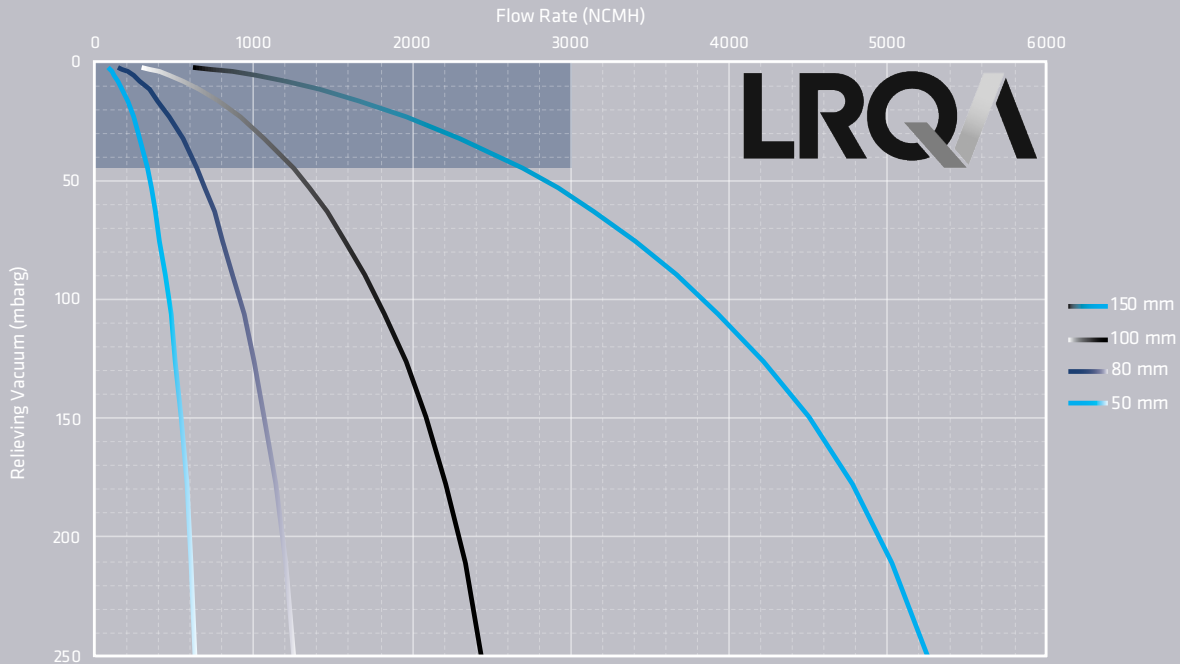

* Flow Curve based on the relieving vacuum being equal to the vacuum setting + 10%

Model: 12E-TWW-0 Vacuum Flow Capacity

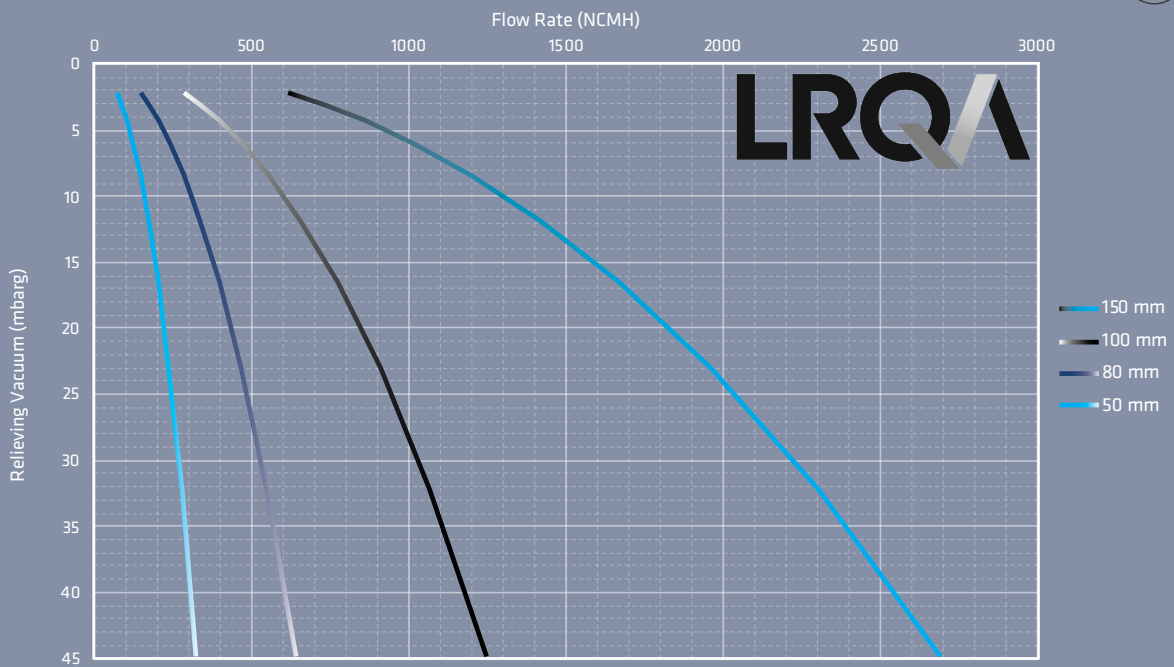

* Flow Curve based on the relieving vacuum being equal to the vacuum setting + 10%

- The test equipment, procedures, and reporting methods utilized by Groth Corporation meet the requirements of standards API 2000/ISO 28300. The equipment, methods, and results have been reviewed and certified by Lloyds.
- Flow data are for tank mounting or end-of-line and includes entrance loss, exit loss and internal losses.
- Flow values based on air at 0°C venting from atmospheric pressure of 1.01325 bara.

FLOW CAPACITY

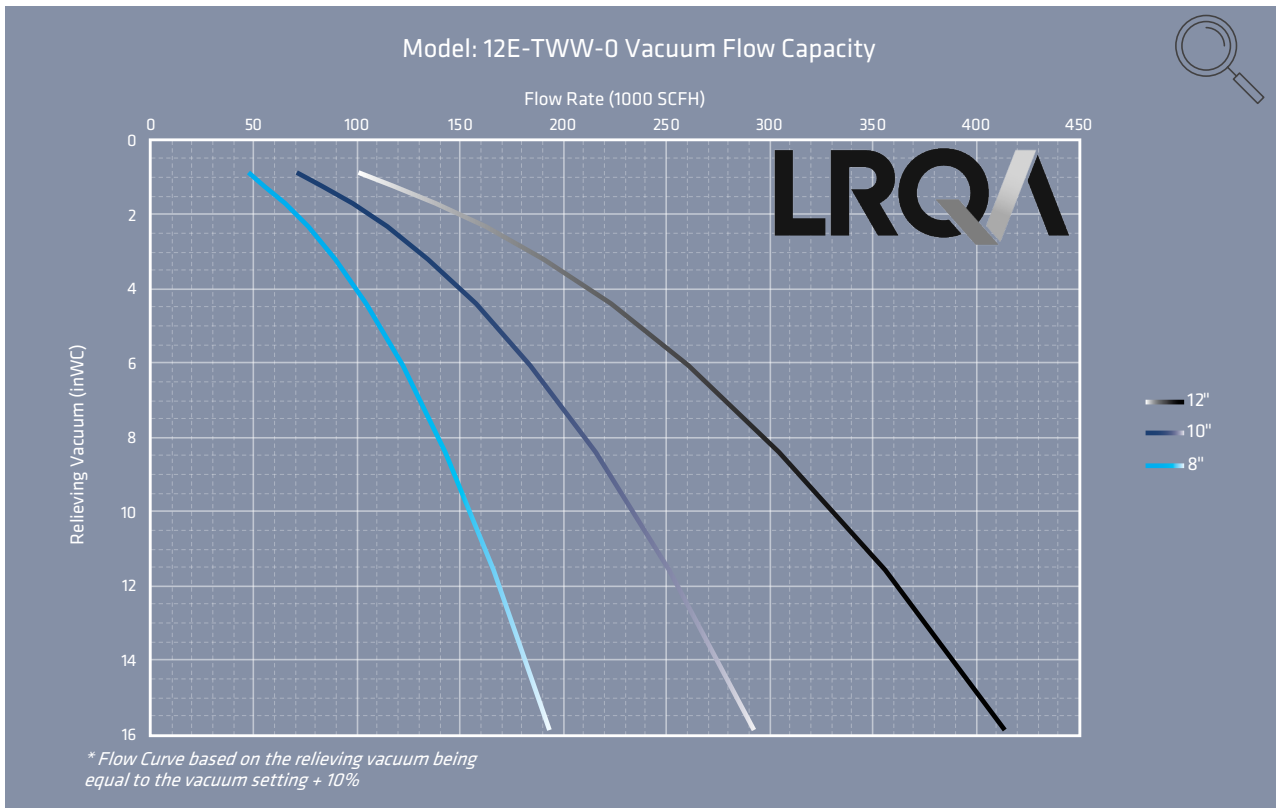
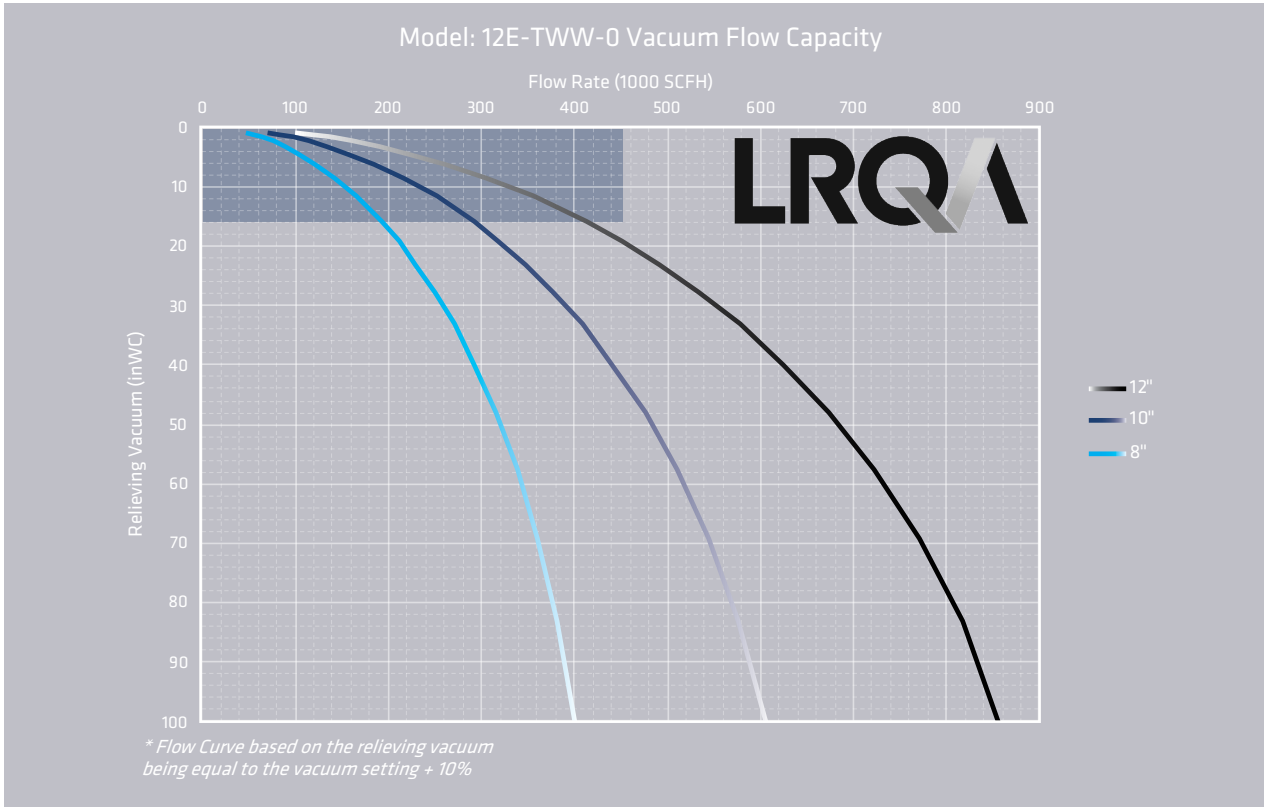

- The test equipment, procedures, and reporting methods utilized by Groth Corporation meet the requirements of standards API 2000/ISO 28300. The equipment, methods, and results have been reviewed and certified by Lloyds.
- Flow data are for tank mounting or end-of-line and includes entrance loss, exit loss and internal losses.
- Flow values based on air at 0°C venting from atmospheric pressure of 1.01325 bara.

FLOW CAPACITY

Model: 12E-TWW-0 Vacuum Flow Capacity

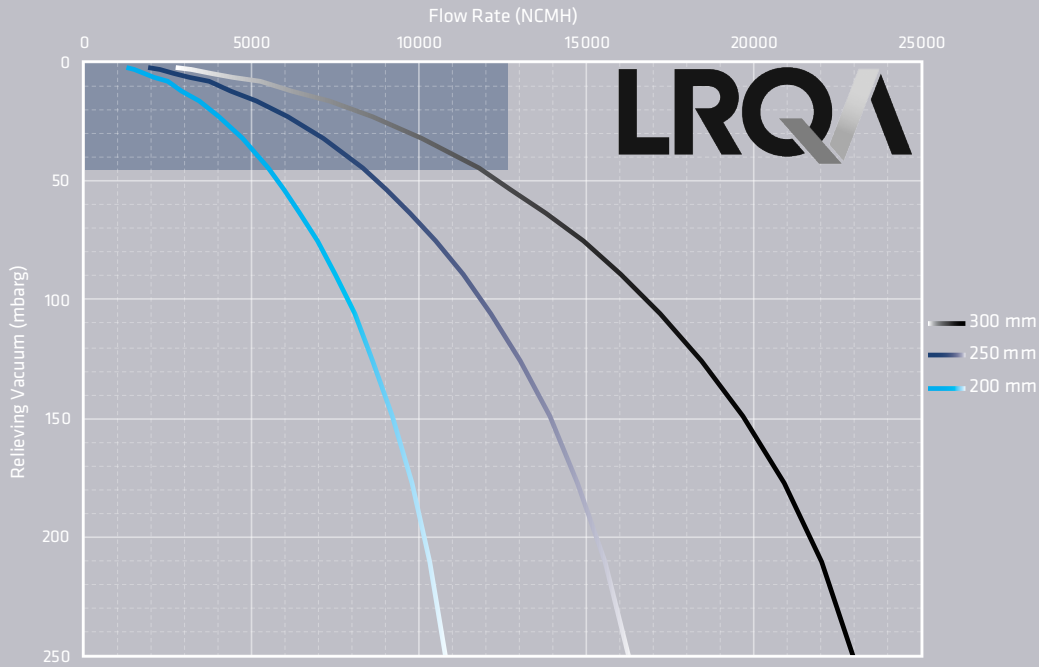

* Flow Curve based on the relieving vacuum being equal to the vacuum setting + 10%

Model: 12E-TWW-0 Vacuum Flow Capacity

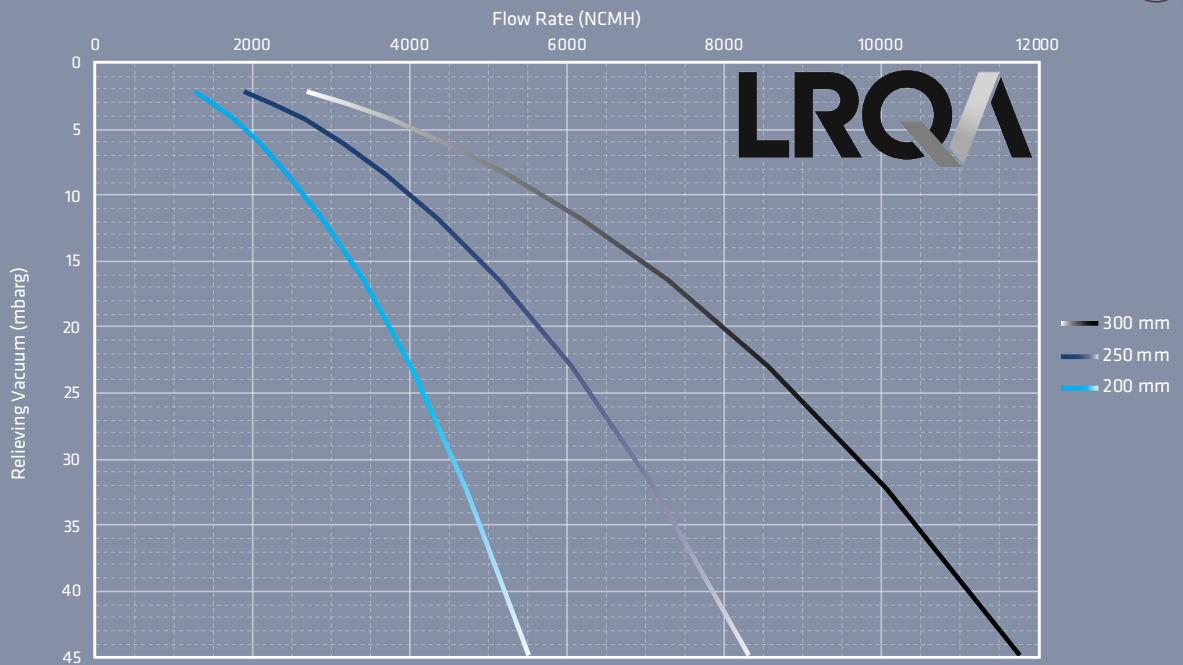

* Flow Curve based on the relieving vacuum being equal to the vacuum setting + 10%

- The test equipment, procedures, and reporting methods utilized by Groth Corporation meet the requirements of standards API 2000/ISO 28300. The equipment, methods, and results have been reviewed and certified by Lloyds.
- Flow data are for tank mounting or end-of-line and includes entrance loss, exit loss and internal losses.
- Flow values based on air at 0°C venting from atmospheric pressure of 1.01325 bara.

HOW TO ORDER

For easy ordering, select proper model numbers

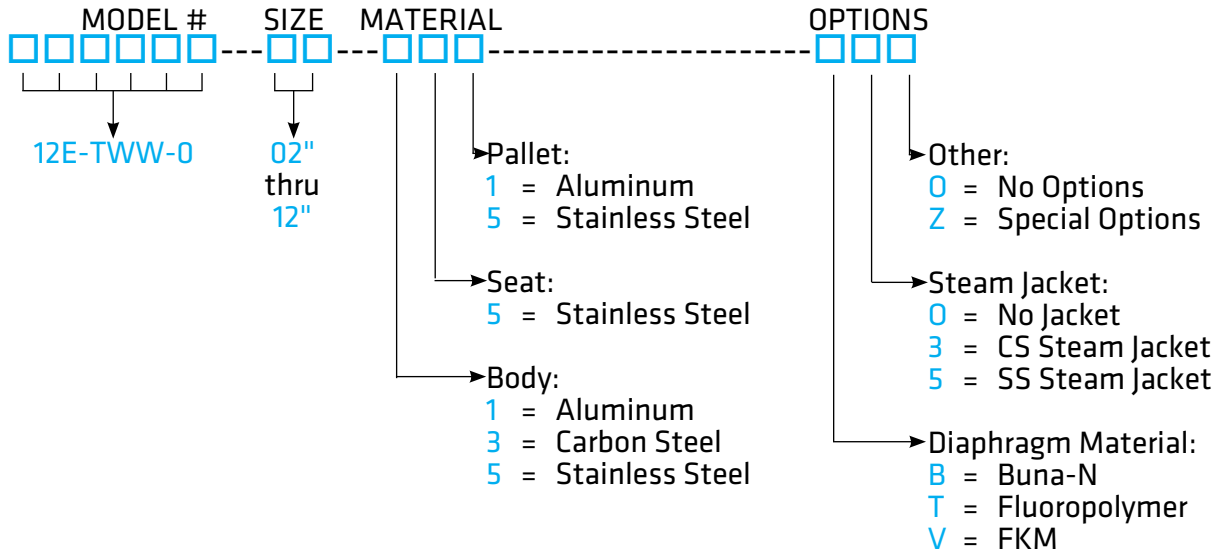

Notes

- Include model number and setting when ordering.
- For special options, consult factory.



GROTHCORP.COM