

Installation, Operation & Maintenance Instructions for Series 2002PR “Mighty Gun” Regulator

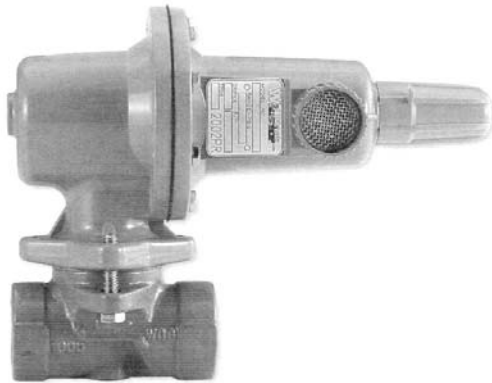

Note: This document is to be used in conjunction with WellMark Document, Section No. 5.3, “Series 2002PR Mighty Gun High Pressure Regulator”, pages 6 through 8.

WARNING!

Over-pressure of this regulator or installation of the regulator in applications which may see pressure levels beyond those for which the regulator is designed may result in leakage and/or catastrophic failure. This failure could result in leaking gas, damage to surrounding equipment, personal injury or death. To prevent such damage/injury the regulator should be installed in a safe location and should be chosen based upon the user’s specific application.

It is highly recommended that suitable pressure-relieving devices, as recommended by appropriate codes or standards, be installed in your system to assure that maximum rated pressures are not exceeded.

Installation

The Series 2002PR Mighty Gun Regulator should be chosen based upon the maximum, differential and outlet pressures as described in Table 1. Flow capacities are listed in Table 2. The operating temperature range is -20°F to 180°F. When choosing and installing a regulator one must ensure that the conditions do not exceed these parameters. Furthermore, large differentials in pressure across the regulator may result in the formation of ice in the orifice area. The resulting decrease in orifice area may affect the regulators ability to flow in sufficient volume for downstream demand. Therefore, large pressure drop applications may require the use of more than one

regulator.

Make sure that line pressure has been eliminated prior to the installation of any regulator. Prior to installation the line should be inspected to ensure that there is no debris that might damage the regulator.

The regulator should be installed with the flow arrow on the side of the body in the correct orientation to flow - i.e. higher pressure upstream, lower regulated pressure downstream. **As is true with most regulators, the Series 2002PR regulator has an outlet pressure rating that is lower than the inlet pressure rating. Over-pressure protection is needed to avoid over-pressure if the actual inlet pressure can exceed the outlet pressure rating.**

The regulator may be installed in any orientation as long as the flow is in proper agreement with the flow arrow on the side of the body. However, the regulator should be positioned such that the screened vent will not collect debris or moisture.

Vent Line Option

The Series 2002PR Mighty Gun Regulator includes a vent in the Upper Housing (24). If there is concern about build-up of gas in a confined location, the Vent Assembly (25) may be removed to allow installation of a remote vent line. With the Vent Assembly removed, a vent line may be installed into the 3/4” NPT port. This vent line should be as large a diameter as possible and should utilize minimal bends and elbows. Furthermore, the vent line opening should be protected from weather or debris and should be checked regularly for blockage.

Startup Operation

WARNING!

Release downstream pressure to prevent a potential over-pressure of the diaphragm. Failure to do so may result in property damage and/or personal injury. Always employ upstream and downstream pressure gauges to monitor startup pressures.

Assuming that the regulator is isolated with shutoff valves on both the upstream and downstream sides, slowly open upstream valve followed by slowly opening the downstream valve. Check all connections for leaks and make necessary output adjustments by manipulating the Adjusting Screw (29) per the adjustment procedures below.

Adjustment

The range of adjustment for a particular regulator is indicated on the nameplate. Different ranges can be achieved by substituting a different Spring (27).

IMPORTANT: If a new spring is installed the nameplate must be remarked to indicate the new pressure range.

Refer to Tables 1 & 2 prior to adjustment for pressure and flow information, assuring that the chosen spring will facilitate the desired pressure regulation and that the maximum pressure output does not exceed the downstream system pressure limits.

Remove the Cap (30) and loosen the Jam Nut (28).

To INCREASE pressure:

Turn Adjustment Screw clockwise.

To DECREASE pressure:

Turn Adjustment Screw counter clockwise.

Once the desired pressure is achieved, hold Adjustment Screw while securing the Jam Nut and replace Cap.

Shutdown

WARNING!

Downstream pressure must be released to prevent an over-pressurization of the diaphragm. Failure to do so may result in property damage and/or personal injury.

Close the upstream block valve followed by closing the downstream block valve. Open the nearest vent valve between the regulator and the downstream block valve.

Maintenance

Routine maintenance should be expected due to normal wear and tear, damage from external sources or debris. The regulator components - especially the moving and sealing parts - should be inspected periodically and replaced as necessary. Frequency of inspection/replacement depends upon severity of conditions, but may also be required by local/state/federal law or industry standards.

Body Area Maintenance

Large pressure drops or large amounts of particulate in the flow will result in accelerated wear on the **Disk Assembly** (9) and **Seat** (2).

Replacing the Disk Assembly and Seat

Remove **Capscrews** (3), separating the **Diaphragm Case** (5) and **Upper Housing** (24) as a unit.

Inspect the **Seat** (2) and remove/replace if necessary. Apply general purpose lubricant to threads of new Seat prior to installation.

Inspect **Disk Assembly** (9) for wear/damage. Should replacement be necessary, remove the **Hair Pin Clip** (13) that holds the Disk Assembly to the **Stem** (10). Install new Disk Assembly by aligning the hole in the Disk Assembly and Stem and reinstalling the Hair Pin Clip.

Should Stem maintenance be required proceed as follows:

Remove the **Boost Body** (6), **Stabilizer** (7) and **Stem Guide** (8) from the Diaphragm Case. Unhook and remove the Stem from the **Lever** (15) and remove from Diaphragm Case.

Remove and inspect the **Diaphragm Case O-Ring** (4) and replace as necessary, being sure to liberally lubricate with a general purpose grease prior to installation in the Boost Body.

To re-assemble, insert the Stem into the Diaphragm Case and hook into the Lever. Be sure to position the Diaphragm Case Assembly such that the pitot tube is inserted into the Outlet side of the Body. Secure the Diaphragm Case Assembly to the body with the two Capscrews. Torque the Capscrews to 25 ft-lbs (34 N•m).

Diaphragm Assembly and Upper Housing Maintenance

IMPORTANT! Prior to accessing the **Spring** (27) all pressure must be released from the Diaphragm Case.

Remove the **Cap** (30), loosen the **Jam Nut** (28) and turn the **Adjusting Screw** (29) **counter-clockwise** until all spring compression is relieved.

Remove the **Upper Housing Capscrews** (31) and remove the Upper Housing. If changing the Spring or adjusting the Upper Housing position, do so at this point and reinstall, Spring, **Upper Spring Seat** (26) and Upper Housing Capscrews and re-adjust regulator per the instructions under **Startup Operation** on Page 1.

If Diaphragm Assembly maintenance is required, remove the Diaphragm Assembly by tilting it such that the **Post & Pin Assembly** (19) slips off the **Lever** (15). If Lever replacement is necessary, free it by removing the **Lever Capscrews** (18). Install the new Lever into the **Lever Retainer** (16) by inserting the **Lever Pin** (17). Secure the entire assembly into the Diaphragm Case by re-installing the Lever Capscrews and torquing them to 7 ft-lbs (9 N•m).

Diaphragm and Spring

Remove the **Diaphragm Head Capscrew** (33), **Spring Seat** (23), **Diaphragm Head** (22) and separate the **Diaphragm** (21) from the **Post & Pin Assembly** (19). After examination and/or replacement, re-assemble by installing Diaphragm on Post & Pin Assembly and re-

installing Diaphragm Head, Spring Seat and Capscrew. Hook the Post & Pin Assembly onto the Lever, rotating the Diaphragm Assembly until holes match up with threaded holes in Diaphragm Case. Unhook the Post & Pin Assembly from the Lever and torque the Diaphragm Head Capscrew to 7 ft-lbs (9 N•m). Re-hook the Post & Pin Assembly to the Lever and re-check diaphragm hole alignment, loosening and adjusting as necessary, making sure to retorque the Diaphragm Head Capscrew appropriately each time.

Once proper hole alignment is achieved re-hook the Post & Pin Assembly to the Lever. Apply lubricant to Upper Spring Seat and install with the Spring. Install the Upper Housing such that the screened vent assembly is in the preferred orientation. Install the Upper Housing Capscrews through the Upper Housing and Diaphragm and screw into the threaded holes in the Diaphragm Case **finger tight**.

Install the Adjustment Screw into the Upper Housing, putting slack into the Diaphragm. Finish tightening the Upper Housing Capscrews, **using a crisscross method**, and tightening each to 7 ft-lbs (9 N•m).

Re-adjust the regulator per the instructions on Page 1 under **Startup Operation**.

Parts List

Item	Description	Qty.	Part No.
1	BODY, 1" NPT, STEEL WCB	1	40520
2	SEAT, 3/32" 316 S.S. •	1	21069
	SEAT, 1/8" 316 S.S. •	1	21070
	SEAT, 3/16" 316 S.S. •	1	21071
	SEAT, 1/4" 316 S.S. •	1	21072
	SEAT, 3/8" 316 S.S. •	1	21073
	SEAT, 1/2" 316 S.S. •	1	21074
	3*	CAP SCREW, STEEL PLATED	2
4	O-RING, VITON® •	1	10423
5	DIAPHRAGM CASE, ALUMINUM	1	40522
6	BOOST BODY	1	40526
7	STABILIZER, NITRILE	1	11036
8	STEM GUIDE, S.S. CF8M	1	21059
9	DISK ASSEMBLY, 316SS/NEOPRENE •	1	21082
	DISK ASSEMBLY, 316SS/NYLON •	1	21083
10	STEM, 316 S.S.	1	21062
11	O-RING, VITON® •	1	05000-0769
12	BACK UP RING, TFE	2	11087
13	HAIR PIN CLIP, STAINLESS STEEL	1	11047
14	PIN, STAINLESS STEEL	1	11046
15	LEVER, STEEL PLATED	1	21061
16	LEVER RETAINER, STEEL PLATED	1	31015
17	LEVER PIN, STAINLESS STEEL	1	11034
18	LEVER CAP SCREW, 316SS	2	11043
19	POST, & PIN ASSY.	1	21130
20	LOCK WASHER, 316SS	2	11045
21	DIAPHRAGM, NITRILE •	1	11037
22	DIAPH. HEAD, STEEL PLATED	1	21078
23	SPRING SEAT, STEEL PLATED	1	21079
24	UPPER HOUSING, ALUMINUM	1	40524
25	VENT ASSEMBLY, PLASTIC	1	11035
26	UPPER SPRING SEAT, STEEL	1	21080
27	SPRING, 5-20 psig	1	11038
	SPRING, 15-40 psig	1	11039
	SPRING, 35-80 psig	1	11040
	SPRING, 70-150 psig	1	11041
28	JAM NUT, STEEL	1	21081
29	ADJUSTING SCREW, STEEL	1	11042
30	CAP, PLASTIC	1	31016
31	CAP SCREW, STEEL PLATED	8	11044
32*	NAME PLATE, ALUMINUM	1	21094
33	CAP SCREW, STEEL PLATED	1	11043

*Not Shown

•Recommended Spare Part

Maximum Spring & Diaphragm Housing Pressure

Maximum pressure to avoid leakage to atmosphere or possible damage to internal parts.	250 psi
Maximum pressure to prevent burst of housing or possible damage to internal parts.	375 psi
Maximum diaphragm housing over-pressure (above set point) to avoid damage to internal parts.	60 psi

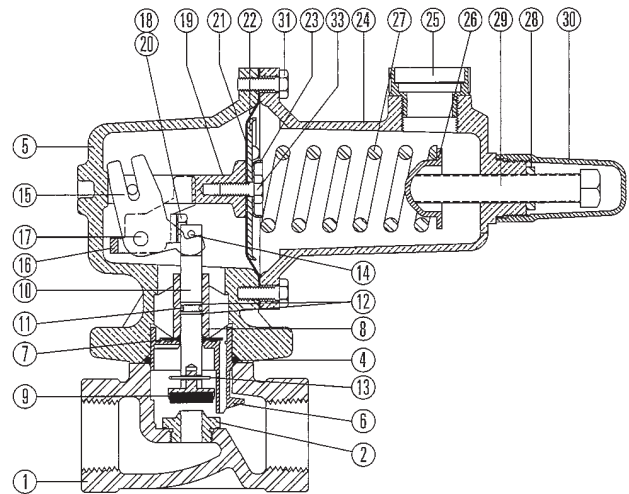

Determining Your "Mighty Gun" Model Number

Example given: A 1" Model 2002PR Pressure Regulator with an Outlet Pressure Range of 70 to 150 psig and 1/4" Seat Ring Orifice.

MODEL 1 PR-4 S 25 S

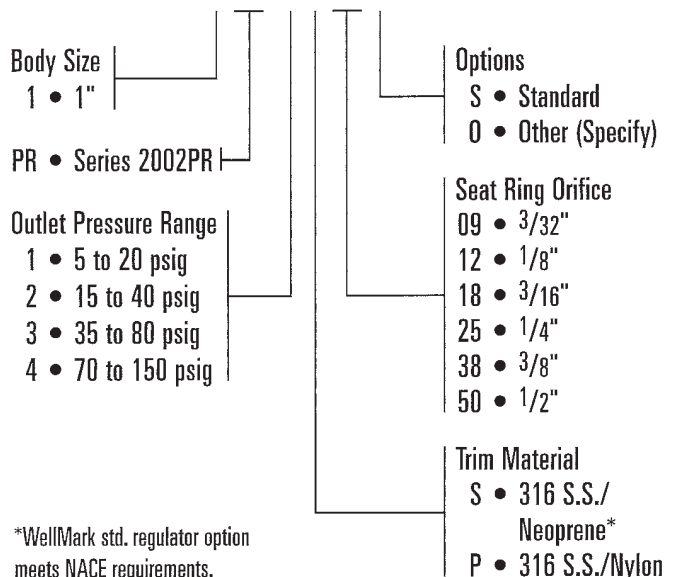

*WellMark std. regulator option meets NACE requirements.

Mighty Gun Regulator Tips

1. Overpressure protection must always be installed to protect against overpressure of regulator, as well as overpressure of downstream equipment in the event of a regulator failure. Also, downstream pressure that is substantially higher than the pressure setting may result in damage to the regulator components.
2. When sizing regulator you should utilize the smallest orifice necessary to accommodate the desired flow/pressure requirement. Pipe size should preferably be 1", but no smaller than 3/4".
3. When picking spring range, if two available spring ranges will accommodate the preferred pressure setting, utilize the lower range spring, as it will allow finer adjustment of the setting.
4. **ADJUSTING SET POINT:** Prior to adjustment the regulator should be flowing 5% or higher of the normal operating flow.
5. Vent should be oriented such that it is protected from water and other material which might collect in the Upper Housing.
6. It is not uncommon that a small amount of gas may migrate through the diaphragm material. Proper venting should be installed to avoid dangerous gas build up.
7. Downstream pressure will change to some degree if upstream pressure changes.
8. **FREEZING:** Freezing is a common issue where the flow of pressurized gas is concerned due to normal refrigerative effects. It is expected that the user will realize approximately 1°F in temperature drop for each 15 psi of differential across the regulator. This may be

particularly problematic during cold weather, when temperatures drop below 45°F (7°C). It is important that the system be designed to alleviate this problem by utilizing one or more methods such as:

- ◆ Multiple regulated pressure drops
- ◆ Application of heat to the gas
- ◆ Removal of water from the gas
- ◆ Utilizing antifreeze solutions in the flow

Failure to consider the temperature-drop aspect may result in ice plugging of the orifice or erratic performance due to ice formation on other components within the regulator.

9. Noise can be generated in regulators with large pressure drops and high flow volumes, resulting in premature wear of regulator components.

10. Regulators inability to maintain published flow rate may be as a result of inefficient piping on both the upstream and downstream side of the regulator. Upstream pressure should be checked at body inlet.

Table 1: Wide-Open Flow Coefficients

Orifice Size	C _g	C _v	C _i
3/32 inch	6.9	0.24	28.5
1/8 inch	12.5	0.43	29.4
3/16 inch	29	0.93	31.2
1/4 inch	50	1.71	29.3
3/8 inch	108	3.42	31.6
1/2 inch	190	5.29	35.9