

# Masoneilan™ SVi™ 1000 Digital Valve Positioner

Instruction Manual (Rev L)

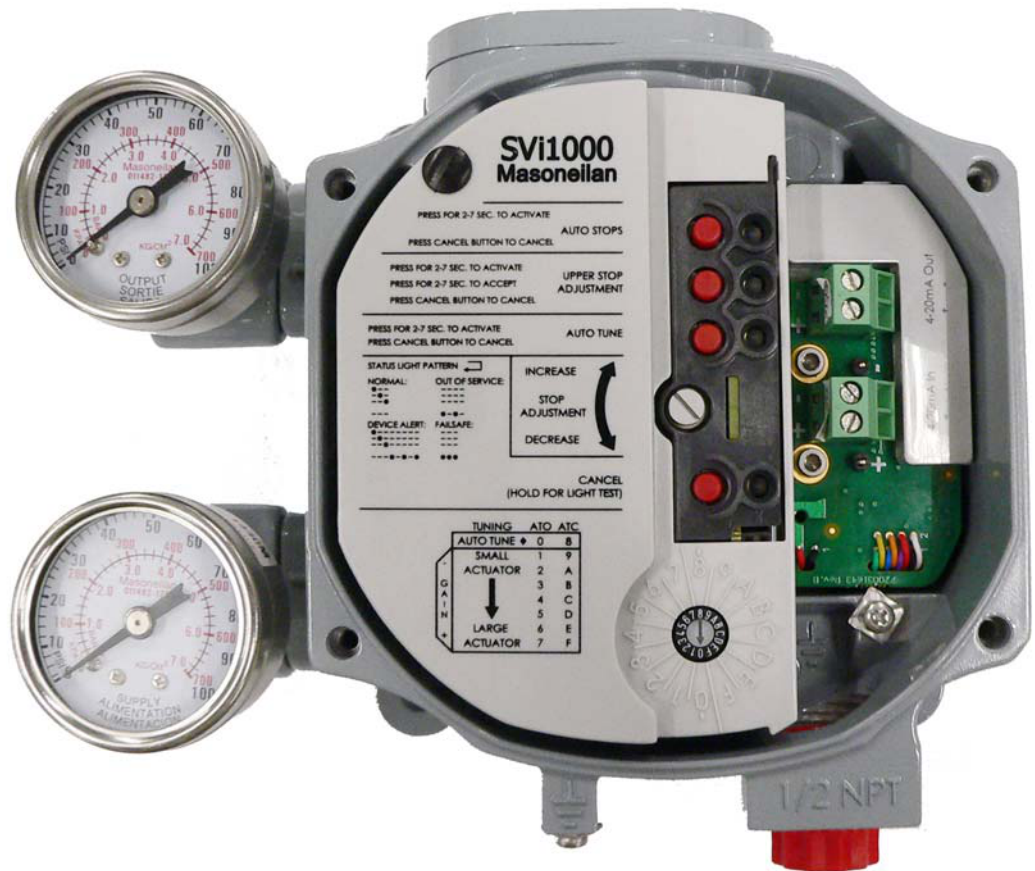

## About this Guide

This instruction manual applies to the following instruments and approved software:

- SVi1000
  - with firmware version 2.2.1 (for use with HART™ 5) or 3.1.1 (for use with HART 7)
  - with **ValVue™ 3 software** version 3.20.0 or greater
  - with a HART Communicator with DD published for SVi1000

The information in this manual is subject to change without prior notice.

The information contained in this manual, in whole or part, shall not be transcribed or copied without Baker Hughes written permission.

In no case does this manual guarantee the merchantability of the digital valve positioner or the software or its adaptability to a specific client needs.

Please report any errors or questions about the information in this manual to your local supplier or visit our website: [valves.bakerhughes.com](http://valves.bakerhughes.com)

## DISCLAIMER

**THESE INSTRUCTIONS PROVIDE THE CUSTOMER/OPERATOR WITH IMPORTANT PROJECT-SPECIFIC REFERENCE INFORMATION IN ADDITION TO THE CUSTOMER/OPERATOR'S NORMAL OPERATION AND MAINTENANCE PROCEDURES. SINCE OPERATION AND MAINTENANCE PHILOSOPHIES VARY, BAKER HUGHES DOES NOT ATTEMPT TO DICTATE SPECIFIC PROCEDURES, BUT TO PROVIDE BASIC LIMITATIONS AND REQUIREMENTS CREATED BY THE TYPE OF EQUIPMENT PROVIDED.**

**THESE INSTRUCTIONS ASSUME THAT OPERATORS ALREADY HAVE A GENERAL UNDERSTANDING OF THE REQUIREMENTS FOR SAFE OPERATION OF MECHANICAL AND ELECTRICAL EQUIPMENT IN POTENTIALLY HAZARDOUS ENVIRONMENTS. THEREFORE, THESE INSTRUCTIONS SHOULD BE INTERPRETED AND APPLIED IN CONJUNCTION WITH THE SAFETY RULES AND REGULATIONS APPLICABLE AT THE SITE AND THE PARTICULAR REQUIREMENTS FOR OPERATION OF OTHER EQUIPMENT AT THE SITE.**

**THESE INSTRUCTIONS DO NOT PURPORT TO COVER ALL DETAILS OR VARIATIONS IN EQUIPMENT NOR TO PROVIDE FOR EVERY POSSIBLE CONTINGENCY TO BE MET IN CONNECTION WITH INSTALLATION, OPERATION OR MAINTENANCE. SHOULD FURTHER INFORMATION BE DESIRED OR SHOULD PARTICULAR PROBLEMS ARISE WHICH ARE NOT COVERED SUFFICIENTLY FOR THE CUSTOMER/OPERATOR'S PURPOSES THE MATTER SHOULD BE REFERRED TO BAKER HUGHES.**

**THE RIGHTS, OBLIGATIONS AND LIABILITIES OF BAKER HUGHES AND THE CUSTOMER/OPERATOR ARE STRICTLY LIMITED TO THOSE EXPRESSLY PROVIDED IN THE CONTRACT RELATING TO THE SUPPLY OF THE EQUIPMENT. NO ADDITIONAL REPRESENTATIONS OR WARRANTIES BY BAKER HUGHES REGARDING THE EQUIPMENT OR ITS USE ARE GIVEN OR IMPLIED BY THE ISSUE OF THESE INSTRUCTIONS.**

**THESE INSTRUCTIONS ARE FURNISHED TO THE CUSTOMER/OPERATOR SOLELY TO ASSIST IN THE INSTALLATION, TESTING, OPERATION, AND/OR MAINTENANCE OF THE EQUIPMENT DESCRIBED. THIS DOCUMENT SHALL NOT BE REPRODUCED IN WHOLE OR IN PART TO ANY THIRD PARTY WITHOUT THE WRITTEN APPROVAL OF BAKER HUGHES.**

## Copyright

All information contained herein is believed to be accurate at the time of publication and is subject to change without notice.

Copyright 2022 Baker Hughes. All rights reserved.

PN 720013363-779-0000 Rev. L.

## Document Changes

Version / Date	Changes
B / 10-2012	Changed Load Limits section Simplified Switch Installation diagram and added Caution about polarity. Changed ID number.
C / 05-2013	Made changes to Figure 7 Rotary Kit Components
D / 09-2013	Added cautions to reference Load Limits section in Install section. Changed Simplified Installation drawing in Load Limits section. Added Cautions about Position Low and Upper Limits. Added text about the 4-20 retransmit galvanic isolation.
E / 02-2014	Rework of the Load Limits section.
F / 03-2016	Updated load limits section. Updated wiring and general descriptions to include retransmit wiring and features. Updated all references to ValVue to reflect on ValVue version 3, along with licensing changes.
G / 08-2017	Fixed mistakes in description of number of entry ports. Fixed mistake in SV mapping for HART Command 3. Fixed mistake in Single Acting Air Delivery. Added Compliance Voltage section. Updated ValVue software download/install section. Add a table for HART Device Information in Specifications. Added section for Troubleshooting Autotune. Added section for Notes on Retransmit Board Upgrade Requirements. Added section for Notes on Aggressiveness. Added How Do I section. Added section for DD Navigation. Updated Fault Matrix.
H / 12-2017	Rework of the Load Limits section.
J / 01-2018	Rework of the Load Limits section. Added section on SVI Physical Characteristic Identification.
K / 05-2019	Added contacts numbers Updated Switches section Add Return Authorization Changed download procedure and links for new site. Updated booster notes. Updated Tight- Shutoff section with closure note. Updated label identification.
L / 10-2022	Rebanded in Baker Hughes format Fault Matrix edited with Fault Category column.

# Contents

1. Safety Information .....	11
Documentation Symbols.....	11
SVi1000 Product Safety .....	12
Documentation Resources for Masoneilan Products .....	13
Related Documentation for the SVi100 DTM .....	13
Masoneilan Help Contacts .....	13
2. Introduction .....	5
About This Manual.....	15
Conventions Used in This Manual .....	15
ValVue Software. ....	16
System Requirements.....	16
ValVue and SVi1000 DTM Trial Version.....	6
Operational Overview. ....	17
SVi1000 Features.....	18
Functionality .....	19
Modes.....	21
LED Light Functions .....	23
3. Installation and Set Up.....	25
Overview.....	25
SVi1000 Dimensions.....	26
Pre-Installation Issues .....	27
Storage .....	27
Unpacking .....	7
ValVue and SVi1000 DTM Software Installation.....	27
Masoneilan Software .....	28
Mounting and Wiring.....	31
Step 1: Mounting the SVi1000 .....	2
Step 2: Connecting the Tubing and Air Supply .....	41
Step 3: Wiring the SVi1000.....	42
4. Check Out and Power Up .....	47
Overview.....	47
Step 1: Inspect the Actuator, Linkages, or Rotary Adapter .....	48
Step 2: Verify Mounting and Linkage Adjustment.....	48
Step 3: Checking the Magnet .....	48
Perform a Visual Inspection .....	48
Use ValVue to Check Magnet Position .....	49
Step 4: Checking the Air Supply.....	49
Step 5: Verify Wiring Connections.....	50
Step 6: Configuration.....	51
Auto Find Stops .....	51
Open Stops Adjustments .....	52
Tuning .....	52

5.	Full Wizard .....	59
	Full Wizard Screen .....	59
	Full Wizard Screen.....	59
	Run the Full Wizard .....	62
6	Operation and Maintenance.....	65
	Principle of Operation .....	65
	Physical and Operational Description.....	66
	Electronics Module.....	66
	Pneumatic Module .....	67
	SVi1000 Maintenance and Repair .....	68
	Adjusting I/P Zero.....	68
	Repair by Replacement.....	68
	Internal Diagnostics .....	68
	FAILSAFE Mode .....	68
	Upgrading Firmware .....	68
7.	Specifications, Spare Parts and References .....	69
	Physical and Operational Specifications .....	69
	Spare Parts.....	74
	Notes on Retransmit Board Upgrade Requirements .....	74
	Preparing to Contact Customer Support or Product Return .....	76
8.	Using the Digital Interfaces .....	79
	Overview.....	79
	Hand Held Communicator .....	81
	SVi1000 HART Commands .....	82
	ValVue Software .....	85
	SVi1000 DD Navigation.....	86
9.	Wiring Theory for an SVi1000 .....	87
	Introduction.....	87
	SVi1000 Setups.....	87
	Split Range Applications.....	88
	System Connections Considerations.....	89
	Wiring Guidelines .....	90
	Grounding Practices .....	90
	Compliance Voltage in Single Drop Current Mode .....	91
	Wire Size and Conduit .....	92
	HART Physical Layer Compliance of the Control System.....	93
	Impedance Constraints .....	93
	Noise Constraints.....	93
	Cabling and Interconnection Requirements .....	94
	Capacitance vs. Length of Cable for HART .....	94
	HART Filter Required for Certain Control System Output Circuits.....	94

10. Optional Switch Load Limits.....	95
Output Switches .....	95
Optional Retransmit Output.....	98
Introduction .....	98
11. Air to Open and Air to Close Actuators .....	99
Actuator Action .....	99
12. SVi1000 Fault Matrix.....	103
Fault Matrix.....	103
13. Air Supply Requirements .....	109
Air Supply Requirements.....	109
14. Adjusting Speed of Response.....	111
Adjusting Speed of Response .....	111
15. Advanced Usage.....	113
Technology to Maximize Savings and Process Performance.....	113
Tight Shutoff Application to Protect from Seat Erosion .....	113
Tight Shutoff Application to High Pressure Liquid Letdown Valve Trim.....	113
16. Determining an SVI Digital Valve Positioner Compliance Voltage in a Control System.....	115
Compliance Test Setup.....	115
17. Glossary .....	117
18. SVI Physical Characteristic Identification.....	125
Body Styles.....	125
Additional Differences Between SVI II AP and SVI II .....	128
SVi1000 Label Identification .....	130
19. How Do I? .....	131
Getting Started Tasks .....	131
Common Tasks.....	131

# Figures

1. Operator Controls - Standard.....	19
2. Optional Digital Switches and Gauges.....	20
3. Optional Position Retransmit .....	20
4. SVi1000 LEDs.....	23
5. Example LED Pattern .....	23
6. SVi1000 Components .....	25
7. SVi1000 Dimensions With and Without Gauges.....	26
8. Resource Center: Search for ValVue .....	28
9. Opening Dialog .....	28
10. Resource Center: Search for SVi1000 DTM.....	29
11. Opening Dialog .....	30
12. Rotary Kit Components.....	33
13. Camflex with Mounting Bracket (Side View).....	33
14. Rotary Mounting Bracket to Valve Actuator.....	34
15. Extension Shaft to the Valve Position Take-off Shaft .....	34
16. Camflex V-Seal .....	37
17. Reciprocating Valve Mounting Bracket for Standard Lever .....	37
18. Magnet Holder and Standard Lever for Reciprocating Valves .....	38
19. SVi1000 Take Off Rod Mounting.....	39
20. Ensure Position Linearity .....	40
21. SVi1000 Lever Installed to IM Assembly.....	40
22. Air Ports .....	41
23. Front Cover .....	44
24. Connections to Electronics Module with Switches (via Interface Board) .....	44
25. Connections to Electronics Module with Position Retransmit (via Interface Board) .....	45
26. Open Stop Adjustment Screw .....	52
27. Preset Tuning Values .....	53
28. Configuration Selection Switch .....	53
29. Configuration Selection Switch .....	55
30. Full Wizard Screen: Device Info.....	60
31. Block Diagram with I/P Converter .....	65
32. Pneumatic Module .....	67
33. Newer Serial Numbers.....	74
34. Older Serial Number .....	75
35. SVi1000 HART Communicator Connections .....	81

36. General Purpose Installation.....	87
37. Split Range with Supplemental Power Supply - Non-Hazardous .....	88
38. Switch Installation Drawing without Load: Configuration Not Allowed .....	95
39. Switch Installation Drawing: Correct Configuration with Load .....	96
40. DCS Switches Wiring Options .....	97
41. Simplified Retransmit Option Installation Drawing .....	98
42. ATO and ATC Action with Linear Positioner Characteristics .....	100
43. ATO and ATC Action in Percentage of Positioner Characteristics .....	101
44. Compliance Voltage Test Setup .....	115
45. SVI II AP: Cover Phase In Started 2015 .....	125
46. SVI II AP: Cover Phase Out Started 2015 .....	126
47. SVi1000: Started Shipping 2011 .....	126
48. SVI II-1: Obsolete.....	126
49. SVI II: Obsolete.....	126
50. SVI I: Obsolete.....	127
51. Cover and Mounting Screw Configuration .....	128
52. Pneumatic Ports.....	128
53. SVI II AP Cover Differences .....	129
54. SVi1000 Diagnostics Labels: No Diagnostics vs. Diagnostics .....	130
55. SVi1000 Diagnostics Labels: With Diagnostics.....	130



# Tables

1. LED Light Patterns and Troubleshooting .....	23
2. Travel Sensor Alignment .....	36
3. Reciprocating Valve Mounting Hole and Turnbuckle Length .....	38
4. Air Supply Requirements .....	41
5. Actuator Settings Configuration Selection Switch Guidelines .....	54
6. Rough Guide to Effects of Changing PID Values .....	56
7. Environmental Specifications .....	69
8. Operational Specifications .....	70
9. Input Signal and Power, Specifications .....	71
10. Construction Material Specifications .....	71
11. System Connectivity .....	72
12. Pneumatics Single Acting Standard Flow .....	72
13. SVi1000 Model Numbering .....	72
14. HART Device Information .....	73
15. SVi1000 HART Commands .....	82
16. Command 48 Additional Status Return Bits .....	83
17. Compliance Voltage for Single Channel Zener with 22 AWG Cable .....	91
18. Compliance Voltage for Galvanic Isolator with 22 AWG Cable .....	91
19. Compliance Voltage for No Barrier with HART Filter and Resistor and 18 AWG Cable .....	92
20. Fault Matrix .....	103
21. Tight Shutoff Parameters for High Pressure Liquid Letdown Trim .....	113
22. Expected Voltage Range at Positioner Terminals .....	116

This page intentionally left blank.

# 1. Safety Information

This section provides safety information and defines the documentation symbols.

## Documentation Symbols

SVi1000 instructions contain warnings, cautions and notes, where necessary, to alert you to safety related or other important information. Read the instructions carefully before installing and maintaining your instrument. Total compliance with all **WARNING**, and **CAUTION** notices is required for safe operation.



Indicates a potentially hazardous situation which, if not avoided, could result in death or serious injury.



Indicates a potentially hazardous situation, which if not avoided could result in property damage or data loss.

**Note:** *Indicates important facts and conditions.*

# SVi1000 Product Safety

For SVi1000 positioners intended for use with industrial compressed air: Ensure that an adequate pressure relief provision is installed when the application of system supply pressure could cause peripheral equipment to malfunction. Installation must be in accordance with local and national compressed air and instrumentation codes.

## *General installation, maintenance or replacement*

- Products must be installed in compliance with all local and national codes and standards by qualified personnel using safe site work practices. Personal Protective Equipment (PPE) must be used per safe site work practices.
- Ensure proper use of fall protection when working at heights, per safe site work practices. Use appropriate safety equipment and practices to prevent the dropping of tools or equipment during installation.
- Under normal operation, compressed supply gas is vented from the SVi1000 to the surrounding area, and may require additional precautions or specialized installations.

## *Intrinsically Safe Installation*

Products certified for use in intrinsically safe installations **MUST BE**:

- Installed, put into service, used and maintained in compliance with national and local regulations and in accordance with the recommendations contained in the relevant standards concerning those environments.
- Used only in situations that comply with the certification conditions shown in this document and after verification of their compatibility with the zone of intended use and the permitted maximum ambient temperature.
- Installed, put into service and maintained by qualified and competent professionals who have undergone suitable training for instrumentation used in such areas.



*Before using these products with fluids/compressed gases other than air or for non-industrial applications, consult the factory. This product is not intended for use in life support systems.*



*Do not use damaged instruments.*



*Installation in poorly ventilated confined areas, with any potential of gases other than oxygen being present, can lead to a risk of personnel asphyxiation.*

Use only genuine replacement parts which are provided by the manufacturer, to guarantee that the products comply with the essential safety requirements of the European Directives.

Changes to specifications, structure, and components used may not lead to the revision of this manual unless such changes affect the function and performance of the product.

# Documentation Resources for Masoneilan Products

Baker Hughes publishes several different resources for documentation on Masoneilan products:

- Bench quick starts contain information related to configuration and testing in a bench top environment.
- Hardware quick starts contain installation information and other basic information related to getting a device installed and very generally configured.
- Hardware instruction manuals contain more complete information for configuration of a device. This manual also includes information on background functionality and special circumstances useful in installation, configuration and operation/ troubleshooting.
- Software manuals contain more complete information for the software configuration of a device. This manual also includes information on background functionality and special circumstances useful in configuration and operation (including diagnostics and their interpretation). These manuals represent the same source material as the online help.
- Handheld documents: Give the DD mappings for the product.

Check the website: <https://valves.bakerhughes.com/resource-center>.

## Related Documentation for the SVi100 DTM

- ValVue documentation: The SVi1000 DTM works inside various software (such as PACTware), however it is designed to work best with out ValVue 3 software. See the ValVue 3 help or Masoneilan Products ValVue 3 Software manual (Ref. 31426).
- SVi1000 online help.

## Masoneilan Help Contacts

Email: [svisupport@bakerhughes.com](mailto:svisupport@bakerhughes.com)

Phone: 888-SVI-LINE (888-784-5463)

This page intentionally left blank.

# 2. Introduction

## About This Manual

The SVi1000 Instruction Manual is intended to help an experienced field technician efficiently install and setup an SVi1000. If you experience problems that are not documented in this guide, call your local representative, go to [valves.bakerhughes.com](http://valves.bakerhughes.com), contact our helpdesk at (+1) 888-784-5463 or email [svisupport@bakerhughes.com](mailto:svisupport@bakerhughes.com). Sales offices are listed on the last page of this document.

The SVi1000 is a high performance, digital valve positioner that combines a local display with remote communication and diagnostic capabilities. The SVi1000 offers a multitude of options that fulfills the broadest range of applications. It also communicates using the HART protocol.

The local user interface and LEDs enables local operations of calibration and configuration functions. Remote operations can be performed with ValVue software or any HART Registered host interface that has been pre-loaded with the Device Description file (DD) for SVi1000.

## Conventions Used in This Manual

Conventions used in this manual are as follows:

- Uppercase, *italicized* letters are used when referencing a term used in the SVi1000 display window. For example, when indicating the term *mode*, as in setup mode, and referring to the display/software operation the convention is to spell mode is all uppercase letters: *MODE*.
- *Italics* is used for emphasis on important items.
- Fields where data is entered or user-entered data is *italicized*.
- Actions performed on buttons, checkboxes, etc. appear bolded. For example: Click **Done**.

# ValVue Software

This section generally discusses the ValVue software that can be used to configure the SVi1000 from a HART configured laptop.

**Note: A cloning feature is available for the SVi1000 digital valve positioner. Cloning transfers the configuration and calibration parameters from one device to another. Cloning operations are to be performed only by Baker Hughes personnel or qualified channel partners trained on properly performing the cloning function. This feature is not available during normal ValVue operation. Contact Baker Hughes or a channel partner for more information.**

## System Requirements

Minimum requirements for all versions of ValVue software are:

- Windows™ 2008 Server (SP2), XP, Windows 7, Windows 8, Windows Server 2012 64 MB RAM
- Hard drive available space 10 G
- A serial or USB port connected to a HART modem with appropriate cable (or Bluetooth)
- For software installation, a connection to the internet to download ValVue and the SVi1000 DTM.

## ValVue and SVi1000 DTM Trial Version

You must download the ValVue software and the SVi1000 DTM software, then install to configure and use the SVi100. See “ValVue and SVi1000 DTM Software Installation” on page 27.

The SVi1000 DTM software and the ValVue software comes with a trial version of ValVue. For 60 days after the initial installation, The ValVue software provides the FDT frame capability in which the SVi1000 DTM software operates. The SVi1000 DTM software provides the capability of configuring, calibrating, diagnosing, trending and much more. After the 60 day trial period ValVue must be registered for continued use. The SVi1000 DTM software functionality includes:

- Setup Wizard
- Set calibration parameters
- Monitor status/error indicators
- Remote calibration of the SVi1000
- Remote operation of the SVi1000
- Trend setpoint, valve position, actuator pressure
- Remote display of valve position, actuator pressure(s)
- Set configuration parameters
- Input/Output configuration
- Remote configuration of the SVi1000
- Backup and restore configuration



## Operational Overview

The SVi1000 is a smart electro-pneumatic positioner that receives a 4 - 20 mA electrical position setpoint signal from the controller and compares the position setpoint input signal to the valve position feedback sensor. The difference between the position setpoint and position feedback is analyzed by the position control algorithm that sets a servo signal for the I/P converter. The output pressure of the I/P is amplified by a pneumatic relay that drives the actuator. Once the error between the setpoint and the valve position feedback is within range, no other correction is applied to the servo signal in order to maintain valve position.

The local user interface and LEDs provide configuration or calibration mode in all operating environments.

The optional position retransmit version transmits the actual position via 4 - 20 mA signal to a supervisory system.

# SVi1000 Features

The SVi1000 digital valve positioner (see Figure 1 on page 19) is suitable for installation indoors or outdoors, and in a corrosive industrial or marine environment and is equipped with the following features:

- Extreme accuracy and reliability
- Extreme digital precision
- Preset values for quick configuration
- Automated valve commissioning
- , quick, responsive control of valve position
- One model for rotary or reciprocating valves
- Local operation/calibration/configuration with a local user interface and LEDs Compatible with air-to-close or air-to-open actuators
- Non-contact magnet coupled (Hall Effect) position sensing for rotary and reciprocating control valves
- Sealed housing with no moving shafts, no shaft penetration, and fully potted electronics
- Digital switches (optional)
- Position retransmit (optional)
- Split range capability
- User-adjustable response times
- Configurable High and Low Position Limits
- Characterize stroke (An accumulated value of 100% travel = 1 stroke. The travel does not need to occur in one movement.):
  - Linear
  - Equal Percentage 50:1 and Equal Percentage 30:1
  - Quick Opening
  - 11 Point Custom Characterization
  - **Camflex™ II rotary control valve** Percentage
- Valve Position Autotuning (not required if presets used)
- Optimized performance regardless of actuator size
- Linearity compensation for actuator linkages with ValVue software
- User-configurable Tight Shutoff at Adjustable Input Signal
- HART compatible
- HART remote operation, calibration, and configuration using ValVue software or a HART handheld communicator, and any HART compatible host

# Functionality

All connections to electronic module in the unit are made through the interface board. The SVi1000 standard interface board has a terminal block with screw connectors.

Optionally, you can order a unit configured with two digital switches or with 4 - 20 mA position retransmit output.

Figure 1 shows the standard interface and lists below the operator controls for all SVi1000 interfaces.

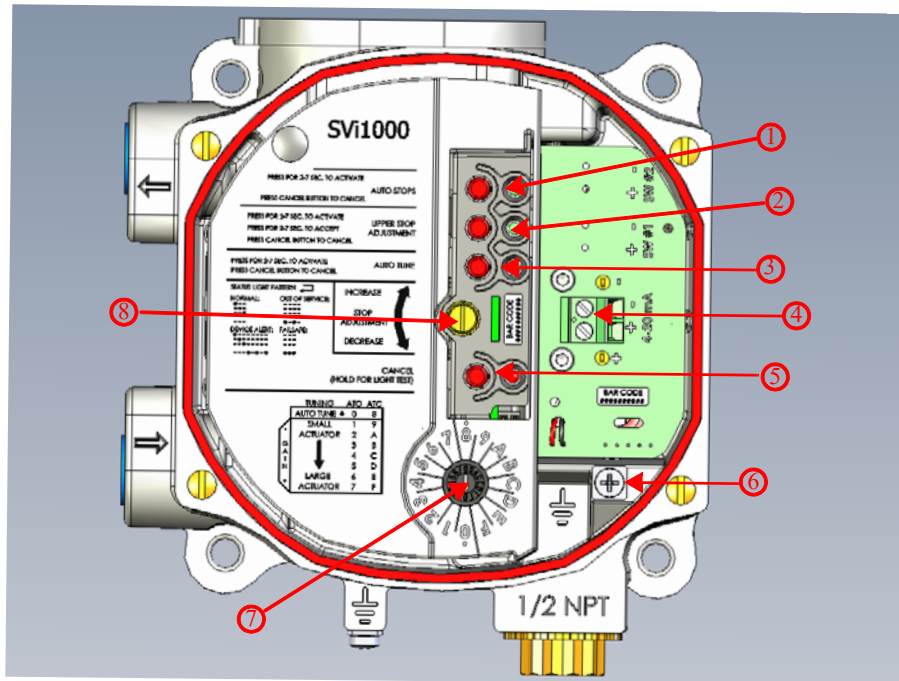

- |                                    |                                   |
|------------------------------------|-----------------------------------|
| ① Auto Find Stops Button and LED 1 | ⑤ Cancel/ Status Button and LED 4 |
| ② Upper Stop Button and LED 2      | ⑥ Ground                          |
| ③ Auto Tune Button and LED 3       | ⑦ Configuration Selection Switch  |
| ④ 4- 20 mA Input Signal            | ⑧ Open Stop Adjustment Screw      |

Figure 1 - Operator Controls - Standard

Figure 2 shows the optional switch interface board and optional gauges.

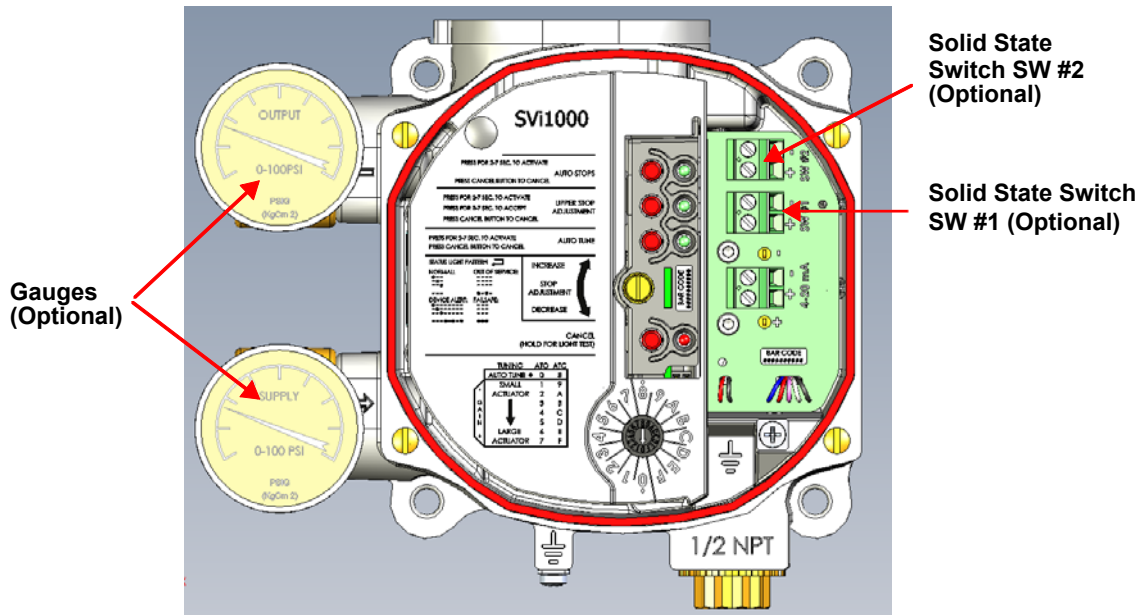

Figure 2 - Optional Digital Switches and Gauges

Figure 3 shows the optional position retransmit interface board and optional gauges.

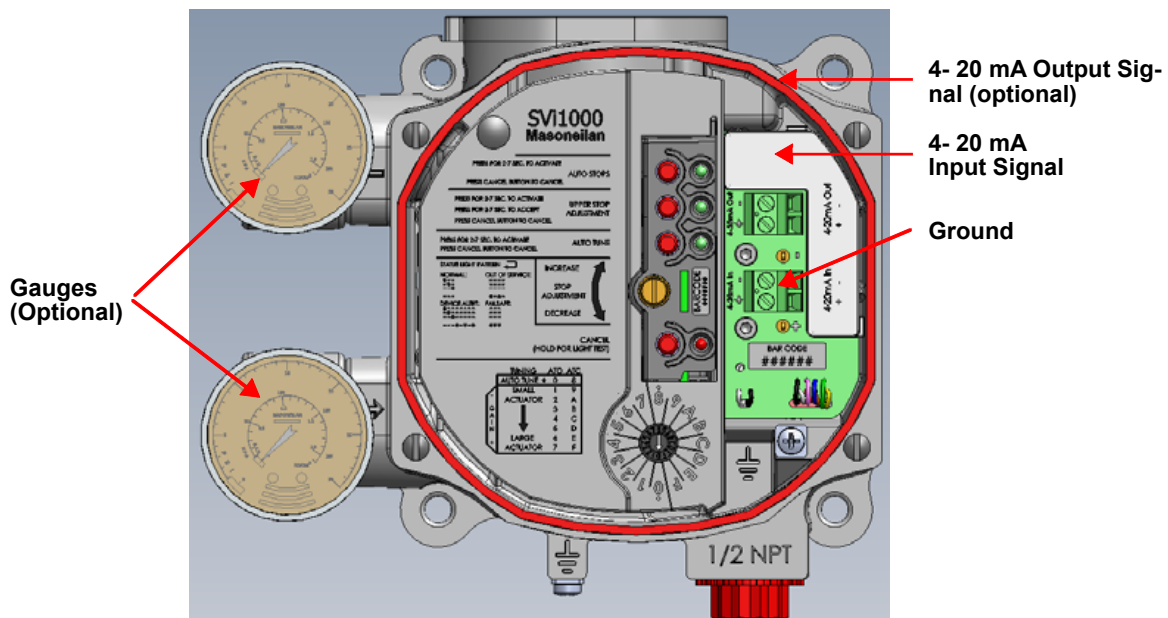

Figure 3 - Optional Position Retransmit

# Modes

The SVi1000 provides the following modes of operation:

- Normal mode
- HART Override mode (Formerly Manual and Setup Modes)
- Failsafe mode
- Commission Process (Via Local User Interface)
  - Find Stops via Local User Interface
  - Manual upper stops adjustment via Local User Interface
  - Autotune via Local User Interface

The SVi1000 always starts up in the mode that the unit was last in before power down, except for failsafe mode when the condition causing fail safe has been corrected.



*Always ensure the SVi1000 has returned to Normal mode after any configuration activity.*

## *Normal Mode*

In this mode the valve follows the 4-20 mA input signal.

## *HART Override mode*

In HART override mode, the local user interface buttons are disabled until any button is pushed, then local control is reestablished.

This, from the instrument interface, functions as Manual and Setup mode from the optional laptop-based software and other HART interface tools.

In HART Override Mode the following tasks are supported over HART by ValVue or DTM based interface:

- Set Characterization (Linear, Equal%(30,50, Camflex), Quick Open and Custom
- Set Near Closed Value
- Configure Tight Shutoff
- Configure Position Fault Limits (Position Error Band and Time 1)
- Run Find Stops
- Perform a Manual Find Stops
- Set Valve Position
- Enable or Disable Bumpless Transfer
- Allow Tune to Override limits
- Set Lower and Upper Position Limits
- Configure Switch I/O
- Run AutoTune (Provided the option is set at the local user interface)
- Set Open Stop Adjustment
- Command valve to full open or closed

<i>Configuration Selection Switch</i>	<p>This switch provides control to the following functions:</p> <ul style="list-style-type: none"> <li>• Actuator Air Action</li> <li>• Select autotuned or preset tuning parameters</li> </ul>
<i>Auto Find Stops</i>	<p>This function automatically sets the lower and upper stops. See “Auto Find Stops” on page 51 for this procedure.</p>
<i>Open Stop Adjustment</i>	<p>Use the Open Stop Adjustment Screw to perform an upper stop adjustment and save it to the device. See “Open Stops Adjustments” on page 52 for this procedure.</p>
<i>Autotuning</i>	<p>The autotune process determines optimum tuning parameters for the valve being commissioned. This function is only active when the Configuration Selector Switch is set to <i>AutoTune</i>. See “Auto Tune” on page 55 for this procedure.</p>
<i>Failsafe Mode</i>	<p><i>Mode</i> When a fault results in Failsafe mode being activated, the output pressure of the SVi1000 is set low and the red status LED illuminates continuously. If the fault is considered self-clearing, then once corrected, the unit returns to Normal mode. If the fault is not self-clearing, then the unit requires a reset after correcting the failsafe condition.</p>
<i>Commission Processes</i>	<p>These are temporary states activated when a local user interface issued command dictates their use. When the positioner is in a Commission Processes a status light indicates this activity (see “LED Light Functions” on page 23). Examples of Commission Processes are Auto Find Stops and Auto Tune. Once a task completes the unit returns to Normal mode.</p>

# LED Light Functions

Figure 4 shows the local user interface LEDs and explains their patterns and timings.

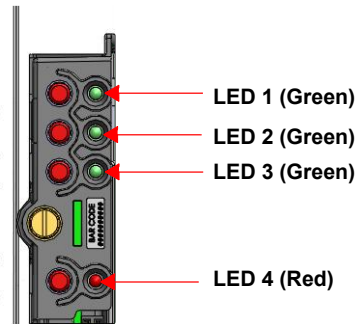

Figure 4 - SVi1000 LEDs

In Table 1 dots represent an LED being active and dashes represent the LEDs off. The pattern shown recurs as long as that condition exists.

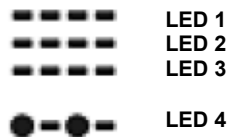
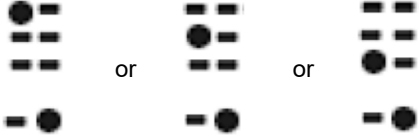

Figure 5 Example LED Pattern

Table 1 - LED Light Patterns and Troubleshooting

Indication	Pattern
Normal mode	
Device Alert (Fault mode (self-correcting))	
Out of Service (HART Override mode)	
Failsafe mode	

**Table 1 - LED Light Patterns and Troubleshooting (Continued)**

Indication	Pattern
Device is not powered or in Low Power mode	All LEDs off. Power is not sufficient.
<b>Troubleshooting</b>	
Device is not powered or in Low Power mode	All LEDs off. Power is not sufficient.
Process Failure	<div style="text-align: center;">  </div> <p>Pattern depends on which process failed and repeats until Cancel button is pushed.</p>
Setting out of range	If a setting is out of range the associated Green LED flashes at twice the rate as normal until an acceptable range is applied.



# 3. Installation and Set Up

## Overview

### CAUTION

Prior to beginning the installation process review the safety information at the beginning of this manual.

### CAUTION

Refer to "Optional Switch Load Limits" on page 95 for guidelines on safely wiring switch load limits.

Figure 6 shows the unit's major components for reference.

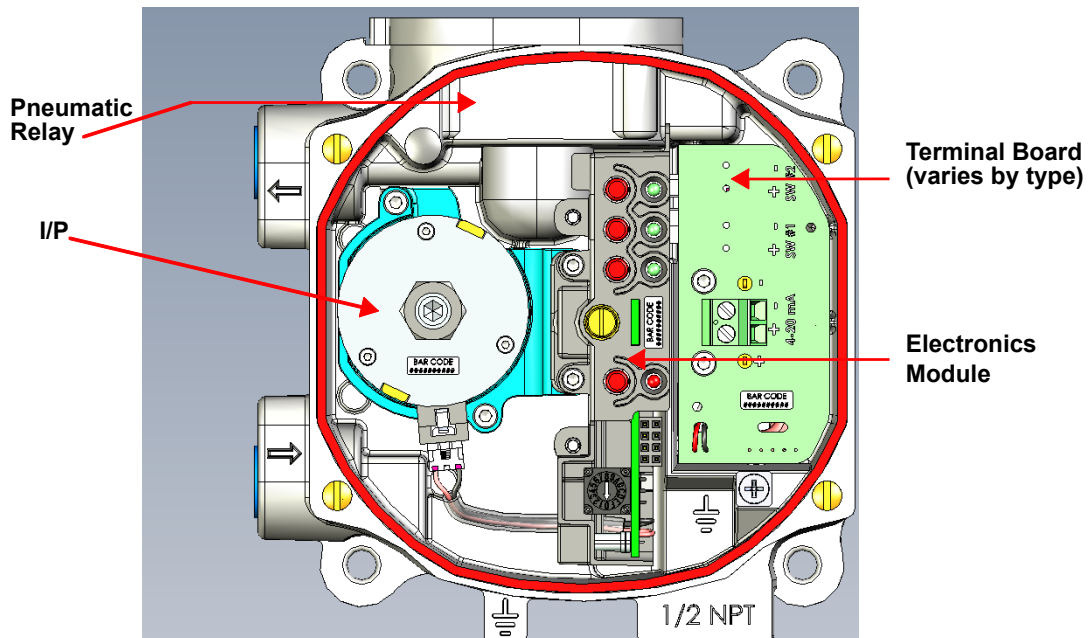

Figure 6 - SVi1000 Components

# SVi1000 Dimensions

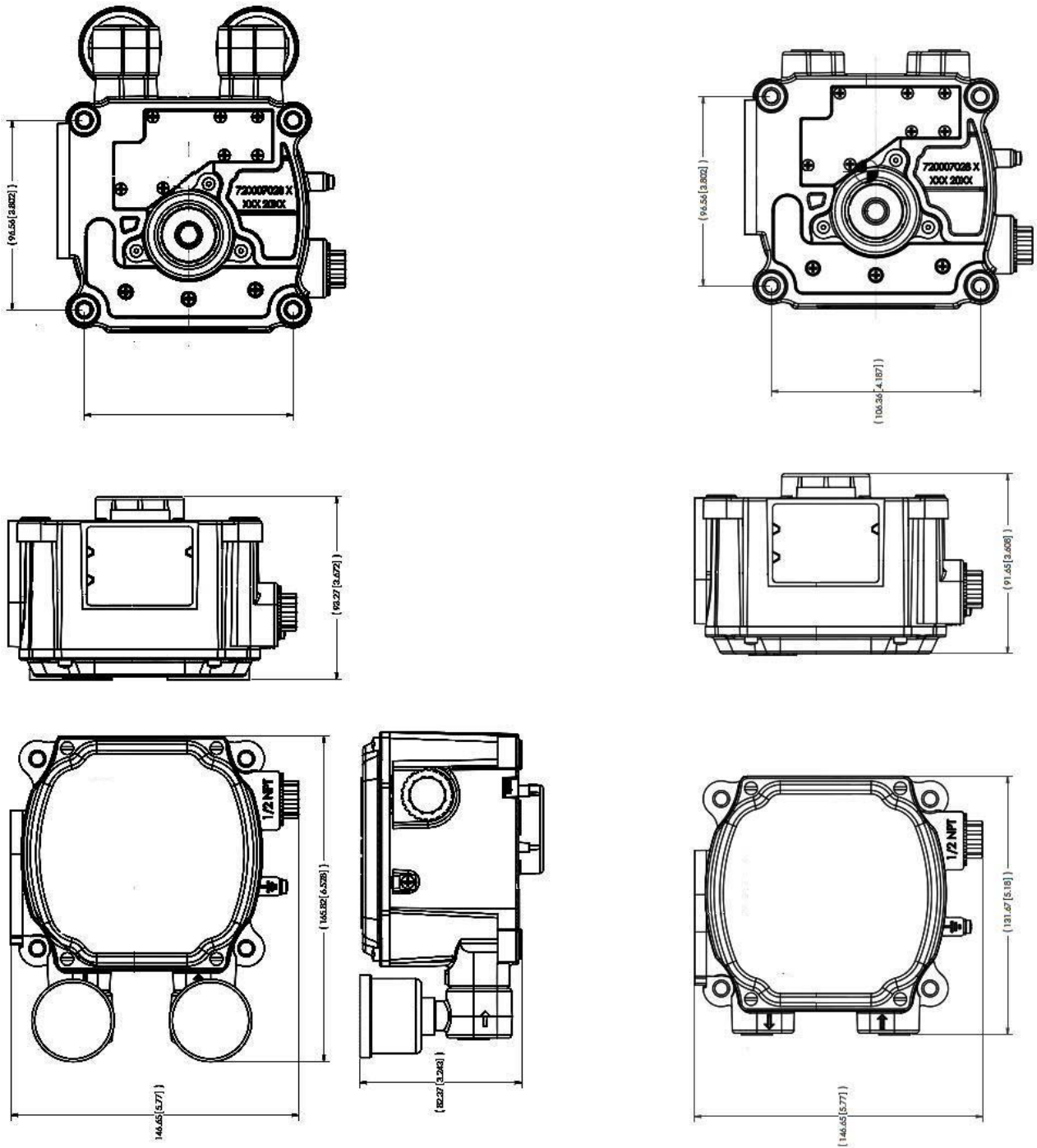

Figure 7 - SVi1000 Dimensions With and Without Gauges

# Pre-Installation Issues

## Storage

If the SVi1000 is stored for a long duration, you must keep the housing sealed against weather, fluids, particles, and insects. To prevent damage to the SVi1000:

- Use the plugs provided with shipment to plug the ¼ NPT air connections, on the positioner and on the air filter regulator set.
- Do not allow standing water to accumulate.
- Observe storage temperature requirements.



*Do not connect a non-intrinsically safe approved PC or HART modem to an intrinsically safe circuit except on the safe area side of the barrier. Do not operate a PC in a hazardous area without compliance to local and plant regulations.*



*Do not connect a HART modem and PC to a control circuit unless the controller is HART compatible or has a HART filter. Loss of control or a process upset may occur if the controller output circuit is not compatible with a HART signal.*

## Unpacking

Exercise care when unpacking the positioner and its mounted accessories. The SVi1000 container includes a Quick Start manual.

## ValVue and SVi1000 DTM Software Installation

This section discusses the ValVue software used to configure the SVi1000 from a HART configured laptop. Minimum requirements are:

- Windows 7, Windows Server 2008 SP2, Windows 8, Windows Server 2012
- 64 MB RAM
- Hard drive available space 10 G
- Available Serial or USB port (or Bluetooth)
- A HART modem and appropriate cables

# Masoneilan Software

## Download and Install ValVue 3

1. Go to the *Resource Center* (<https://valves.bakerhughes.com/resource-center>) and enter *ValVue* in the search field (arrow in Figure 8).

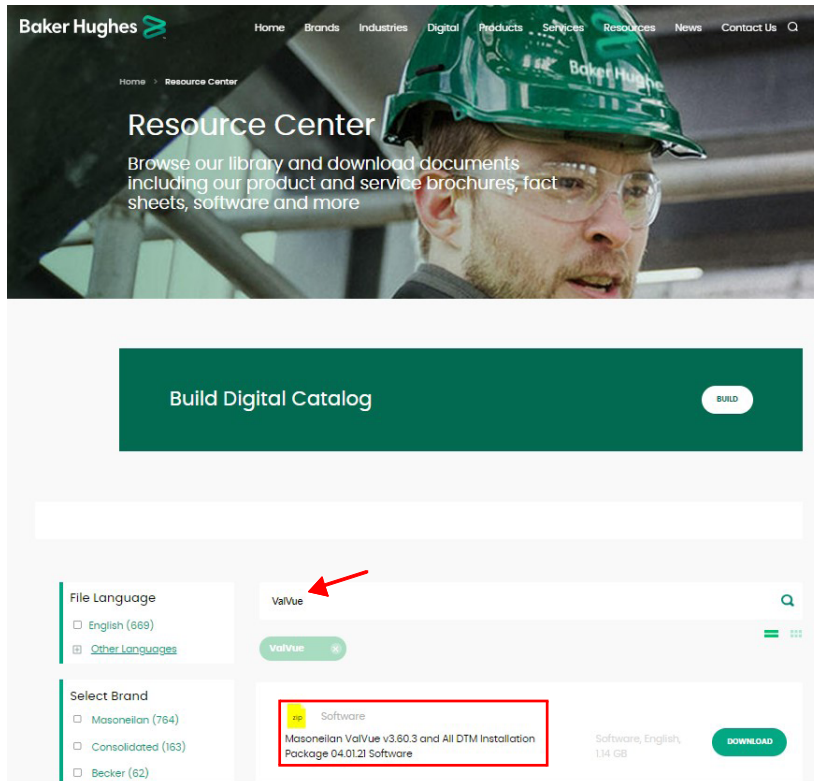

Figure 8 - Resource Center: Search for ValVue

The results appear (red box in Figure 8).

2. Click **Download** below *ValVue Installer Download* and Figure 9 appears.

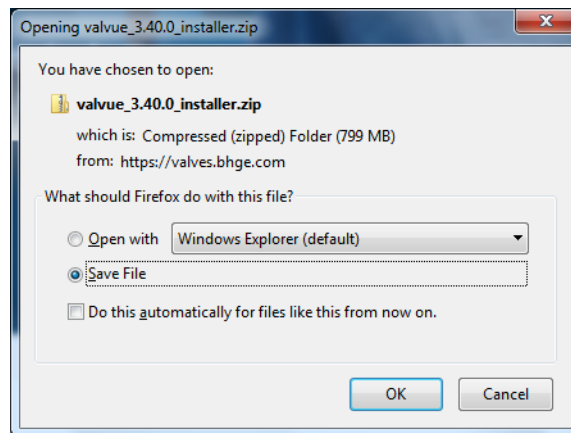

Figure 9 - Opening Dialog

**Note:** The dialog that appears for download varies by the program used.

3. Click **Save File**, click **OK** and it saves by default to the *Windows Downloads* folder.

**Note: For fastest installation, save the download file to your laptop/PC. Don't install from the website.**

4. Open *Windows Explorer* and click the **Windows Downloads** folder.

**Note: If you have a previous install of ValVue 3 you are prompted to uninstall first and then you must run the installer again to finish the upgrade.**

**Note: If you are upgrading from ValVue 2.x you must update the SQL database location to match ValVue 3's.**

5. Double-click on the installer and follow the instructions to install.

## Download and Install the SVi1000 DTM

1. Go to the *Resource Center* (<https://valves.bakerhughes.com/resource-center>) and enter *SVi1000 DTM* in the search field (red arrow in Figure 10).

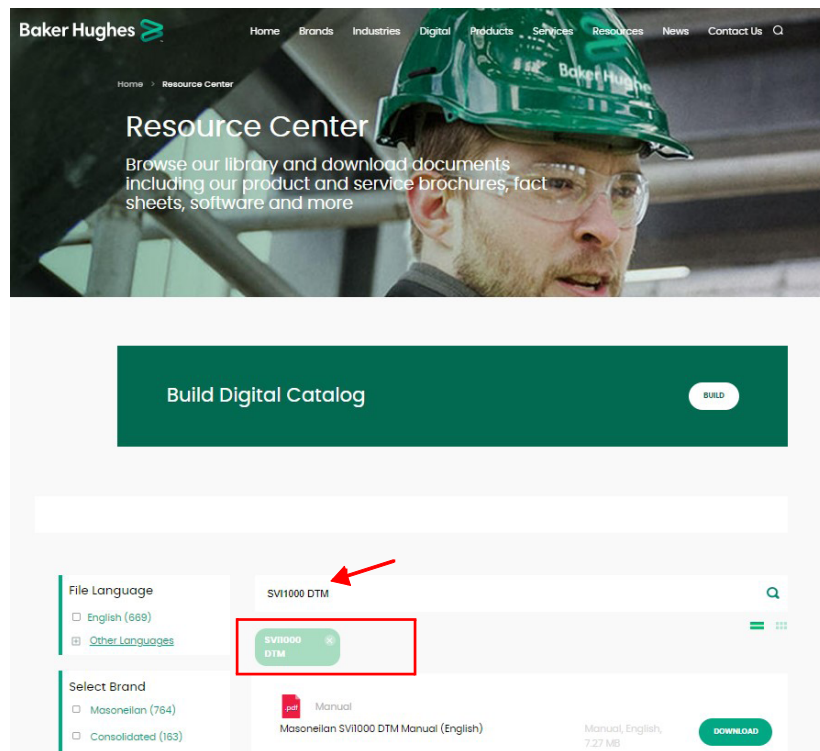

**Figure 10 - Resource Center: Search for SVi1000 DTM**

The results appear (red box in Figure 10).

2. Select **Download** below *SVi1000 DTM* and Figure 11 appears.

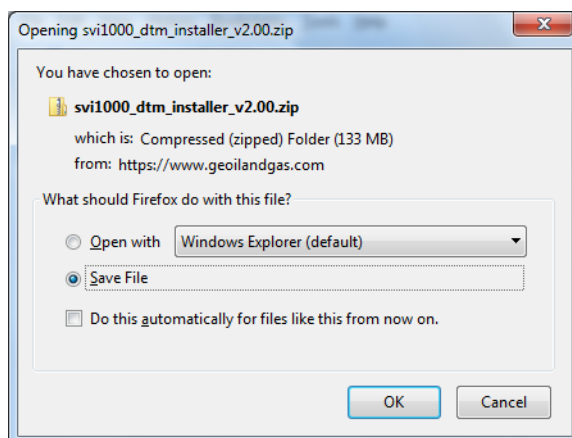

Figure 11 - Opening Dialog

**Note:** *The dialog that appears for download varies by the program used.*

3. Click **Save File**, click **OK** and it saves to the *Windows Downloads* folder.

**Note:** *For fastest installation, save the download file to your laptop/PC. Don't install from the website.*

4. Open *Windows Explorer* and click the **Windows Downloads** folder.

**Note:** *If you have a previous install of the SVi1000 DTM you are prompted to uninstall first and then you must run the installer again to finish the upgrade.*

5. Double-click on the installer and follow the instructions to install.

## Mounting and Wiring

This section describes how to mount and wire the SVi1000, which includes:

- “Step 1: Mounting the SVi1000” on page 32.
  - “Step 1: Mounting the SVi1000 on Rotary Valves” on page 33
  - “Step 1: Mounting the SVi1000 on Reciprocating Valves” on page 37
- “Step 2: Connecting the Tubing and Air Supply” on page 41
- “Step 3: Wiring the SVi1000” on page 42



*Failure to adhere to the requirements listed in this manual may cause loss of life and property.*

*Before installing or using this instrument, **READ THE INSTRUCTIONS CAREFULLY.** Refer to “Wiring Theory for an SVi1000” on page 87 for detailed instructions.*

## Step 1: Mounting the SVi1000

This guide provides installation instructions for mounting an SVi1000 on both rotary and reciprocating style valves. The mounting process can be broken down into the following:

1. Attach the mounting bracket to the actuator.
2. Install the magnetic assembly.
3. Assemble the SVi1000 on the mounting bracket.

### CAUTION

*The SVi1000 cover must be in place and secured using all four screws during operation.*

**Note: Mount the SVi1000 with the conduit connection down in order to facilitate drainage of condensate from the conduit.**

### Necessary Precautions

To avoid injury or the process being affected when installing or replacing an SVi1000 digital valve positioner on a control valve, ensure that:

- If the valve is located in a hazardous area, ensure the area has been certified as *safe* or that all electrical power to the area has been disconnected before removing any covers or disconnecting any leads.
- Shut off air supply to the actuator and to any valve mounted equipment.
- Ensure the valve is isolated from the process by either shutting off the process or using bypass valves for isolation. Tag shutoff or bypass valves to guard against a *turn-on* while work is in progress.
- Bleed air from actuator and check that valve is in its de-energized position.

For the procedure to install rotary and reciprocating mounting kits on valves, refer to the instructions contained in the valve's mounting box kit.



## Step 1: Mounting the SVi1000 on Rotary Valves

This section describes the procedure for mounting the SVi1000 on rotary control valves that have less than 60° rotation, such as the Camflex.

Figure 12 shows the kit components.

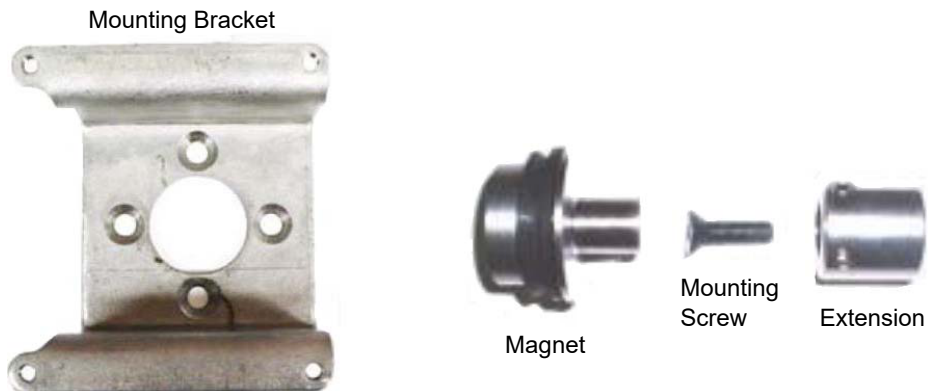

Figure 12 - Rotary Kit Components

Figure 13 shows a side view of a Camflex actuator, the SVi1000, and a mounting bracket.

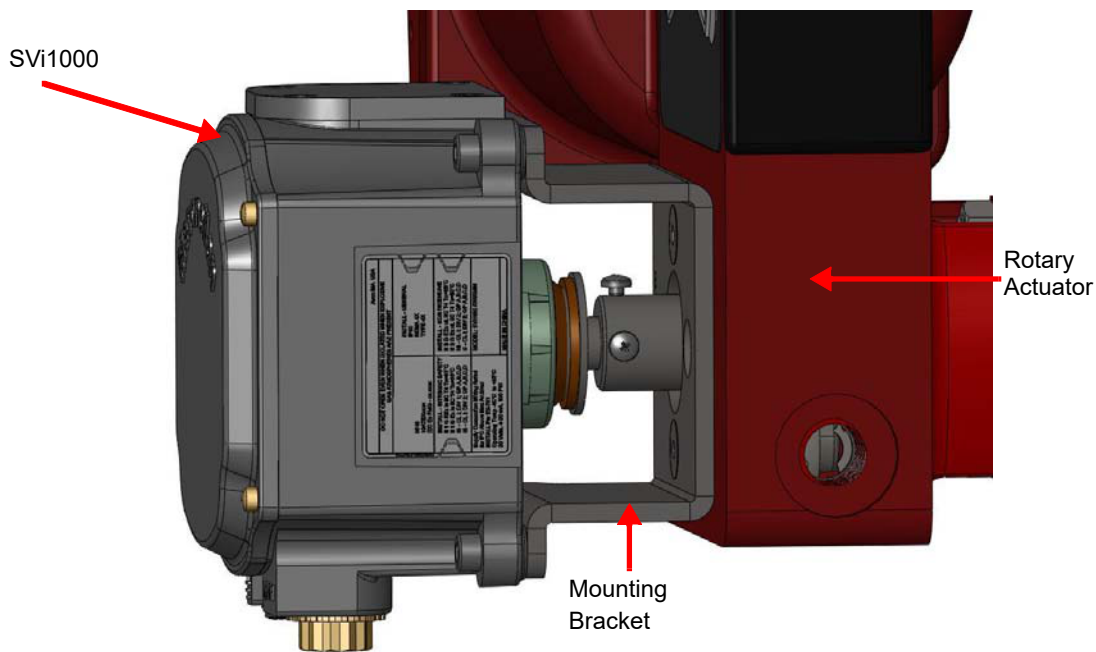

Figure 13 - Camflex with Mounting Bracket (Side View)

Tools required:

- M5 Hex Key
- M4 Hex Key
- M3 Hex Key

To mount the SVi1000:

1. Attach the mounting bracket to actuator (Figure 14).

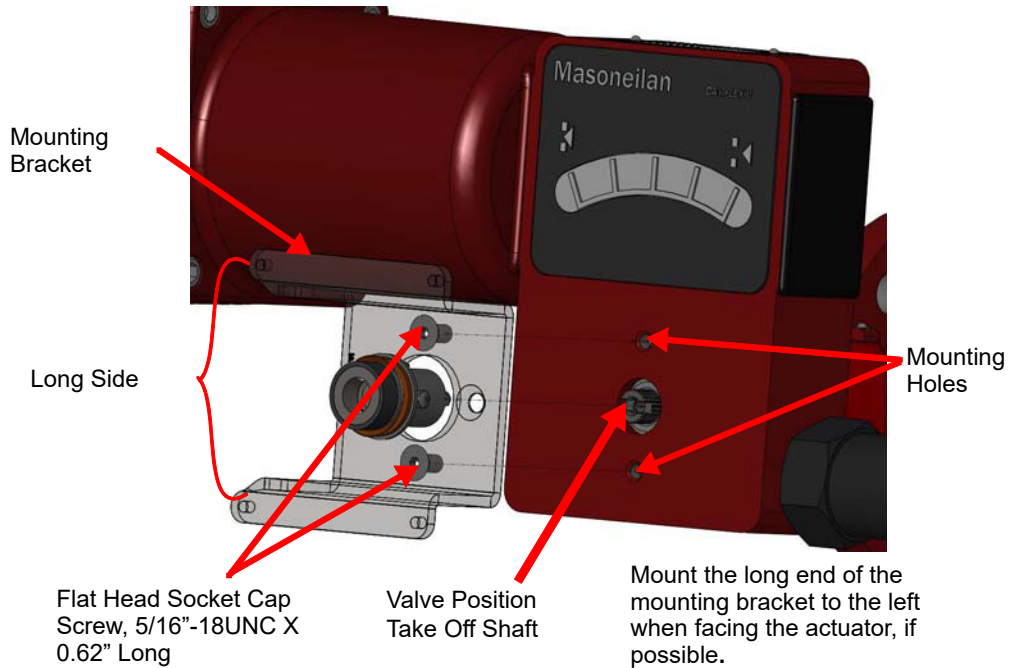

**Figure 14 - Rotary Mounting Bracket to Valve Actuator**

2. Bolt the extension shaft to the valve position take-off shaft (Figure 15).

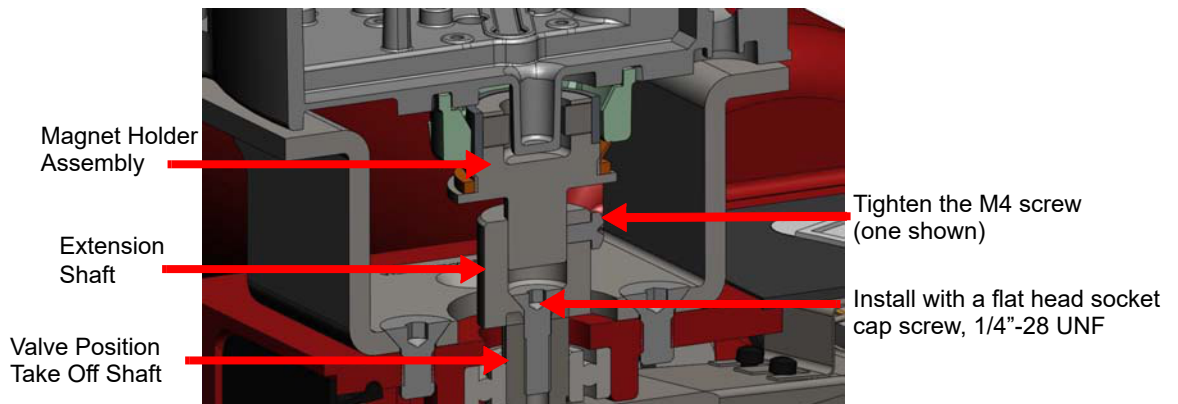

**Figure 15 - Extension Shaft to the Valve Position Take-off Shaft**





*Internal valve pressure*      The valve plug shaft is pushed out to the mechanical stops, usually a thrust bearing. On valves where the valve position take-off is mounted directly on the end of the plug shaft, a Camflex for example, the shaft must be bearing on its stop to properly set up the SVi1000 digital valve positioner. During hydrostatic testing the shaft is thrust to its stop and a normally tightened packing retains it in that position.

*Vacuum service*              The valve shaft is drawn into the body by the vacuum acting on the shaft, but the magnetic coupling must be assembled flush with the mounting bracket.

3. Perform magnet install and travel sensor alignment by:

- a. Sliding the magnet holder into the extension shaft. The magnets are in the magnet holder ring. The magnetic axis is the imaginary line through the center of both magnets.
- b. Rotating the magnet holder so that the magnet axis is vertical when the valve is in the closed position (Table 2). If mounting kit is installed on fail-open valve, apply air to the actuator to close the valve before installing magnet holder.

**Table 2 - Travel Sensor Alignment**

<b>Rotary Mounting System</b>	<b>Stroke Direction</b>	<b>Magnet Orientation</b>	<b>Valve Position</b>	<b>Sensor Counts</b>
Rotary	<60° Rotation Clockwise or counter-clockwise rotation	 (0°)	Closed (0%)	0 +/- 1000
	>60° Rotation Clockwise with increasing setpoint	 (-45°)	Full Open or Full Closed	-8000 +/- 1500 or +8000 +/- 1500
	>60° Rotation Counter Clockwise rotation with increasing setpoint	 (+45°)	Full Open or Full Closed	-8000 +/- 1500 or +8000 +/- 1500
General Rule for other configurations	Any amount of rotation Clockwise or counter-clockwise	 (0°)	50% Travel (Mid-Stroke)	0 +/- 1000

- c. Aligning the end of the magnet holder flush with the end of the mounting bracket. Secure the magnet holder with two M4 set screws.
- d. Sliding the V-Seal over the magnet holder. You can also check the magnet using ValVue software by reading sensor counts and comparing them to Table 2.
4. Secure the SVi1000 onto the mounting bracket using four M6 x 20 mm socket head cap screws.
5. Ensure no interference exists with the position sensor protrusion.

6. Ensure that the V-Seal makes contact with the skirt around the alignment ring on the SVi1000 (Figure 16).

## CAUTION

*Do not carry the positioner by the alignment ring.*

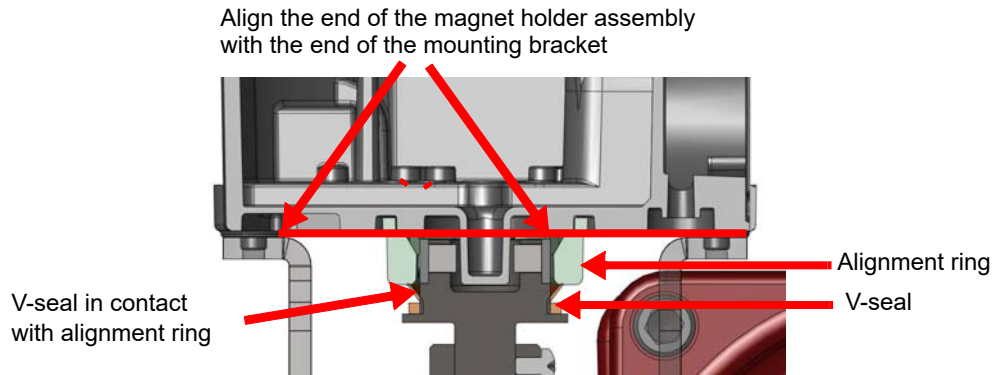

Figure 16 - Camflex V-Seal

### Step 1: Mounting the SVi1000 on Reciprocating Valves

This section describes the procedure for mounting the SVi1000 on Reciprocating Valves, using Masoneilan's 87/88 Multi-Spring actuators as an example. Figure 17 on page 37 shows the standard lever for all size installations. See "Integrated Magnet Assembly" on page 40 for the optional IM assembly. Tools required:

- 7/16" Combination Wrench (2 required)
- 1/2" Combination Wrench
- M4 Hex Key
- 3/8" Combination Wrench
- Phillips Head Screw Driver
- M3 Hex Key

1. Mount the standard reciprocating mounting bracket to the valve using two (2) 5/16 - 18 UNC cap screws.

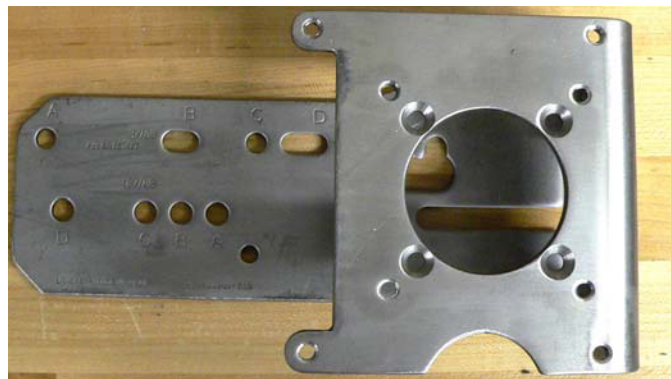
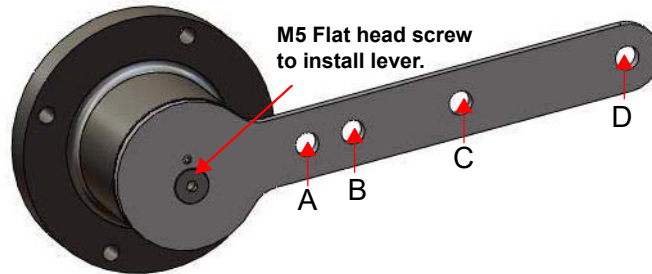

Figure 17 - Reciprocating Valve Mounting Bracket for Standard Lever

- Ensure that the lever is pinned to the magnet assembly and held securely by an M5 flat head screw to ensure that the magnet axis is vertical when the lever is in the valve closed position. Tighten the lever screw securely (Figure 18).



**Figure 18 - Magnet Holder and Standard Lever for Reciprocating Valves**

- Select mounting hole for the stroke of the valve. Unless otherwise specified, the SVi1000 mounting assumes that the actuator is in the normal upright position. The mounting hole in the slotted opening of the mounting bracket must be left when facing the actuator, with the actuator in the upright position.

**Table 3 - Reciprocating Valve Mounting Hole and Turnbuckle Length**

Masoneilan Actuator Size 87/88	Stroke	Mounting Hole	Lever Hole	Turnbuckle Length
6 and 10	0.5 - 0.8" (12.7 - 20.32 mm)	A	A	1.25" (31.75 mm)
10	0.5 - 0.8" (12.7 - 20.32 mm)	A	A	1.25" (31.75 mm)
10	>0.8 – 1.5" (20.32 - 41.5 mm)	B	B	1.25" (31.75 mm)
16	0.5 - 0.8" (12.7 - 20.32 mm)	B	A	2.90" (73.66 mm)
16	>0.8 – 1.5" (20.32 - 41.5 mm)	C	B	2.90" (73.66 mm)
16	>1.5 – 2.5" (41.5 - 63.5 mm)	D	C	2.90" (73.66 mm)
23	0.5 - 0.8" (12.7 - 20.32 mm)	B	A	5.25" (133.35 mm)
23	>0.8 – 1.5" (20.32 - 41.5 mm)	C	B	5.25" (133.35 mm)

**Table 3 - Reciprocating Valve Mounting Hole and Turnbuckle Length (Continued)**

Masoneilan Actuator Size 87/88	Stroke	Mounting Hole	Lever Hole	Turnbuckle Length
23	>1.5 – 2.5" (41.5 - 63.5 mm)	D	C	5.25" (133.35 mm)

- Thread the take-off rod to the actuator stem connector (Figure 19).

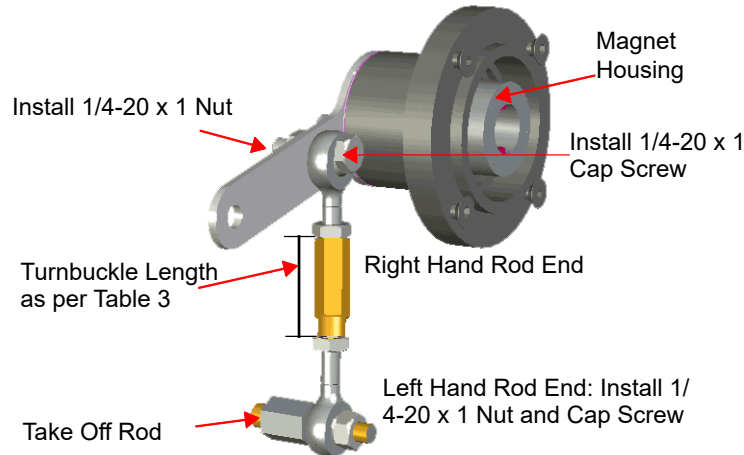

**Figure 19 - SVi1000 Take Off Rod Mounting**

- Attach the right hand threaded rod end to the lever using a 1/4 - 20 x 1" cap screw and nut (Figure 19).
- Thread the right hand lock nut and turnbuckle onto the right hand rod end approximately two turns. Turnbuckle length is a function of actuator size. Refer to Table 3 on page 38.
- Secure the magnet housing assembly, including the lever and right hand rod end, to the bracket using four M5 X 10 mm flat head screws.
- Attach the left hand threaded rod end to the take-off rod with 1/4 - 20 UNC nut and thread the left hand lock nut onto the rod end.
- Move the valve to its closed position. For air to:
  - Close: Requires using air pressure in the actuator to fully stroke the actuator.
  - Open: Vent the actuator of air pressure.
- Thread the turnbuckle onto the left hand threaded rod end (Figure 19).
- Adjust the turnbuckle until the hole in the lever is aligned with the alignment hole in the bracket. Tighten both turnbuckle lock nuts (Figure 19).
- Ensure the adjustable link turnbuckle is parallel to the valve stem. Verify that the hole in the lever aligns with the alignment hole in the bracket when the valve is in the closed position. Check that the bracket is mounted using the proper holes (Figure 20).

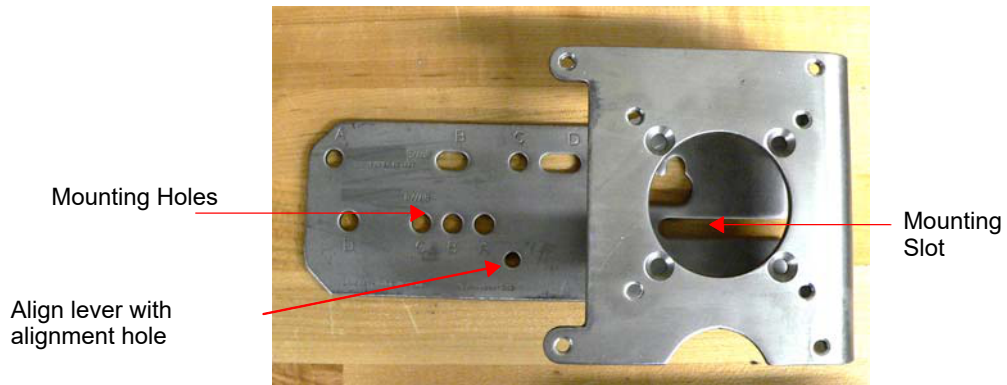
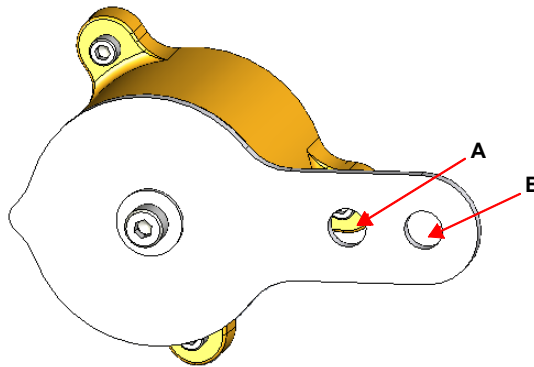

**Figure 20 - Ensure Position Linearity**

13. Mount the SVi1000 to the bracket and secure with four M6 socket head cap screws.

### **Integrated Magnet Assembly**

The IM (Integrated Magnet) assembly kit is an optional assembly intended for custom mounting by the end user for reciprocating actuators (Figure 21). This kit allows for more leeway in installation.



**Figure 21 - SVi1000 Lever Installed to IM Assembly**

**Note:** You can use a custom bracket with the IM option. Refer to drawing #720012413 for assistance.



## Step 2: Connecting the Tubing and Air Supply

To connect the air supply:

1. Install the tubing to the air supply port. Minimum tubing diameter 1/4" (Figure 22).

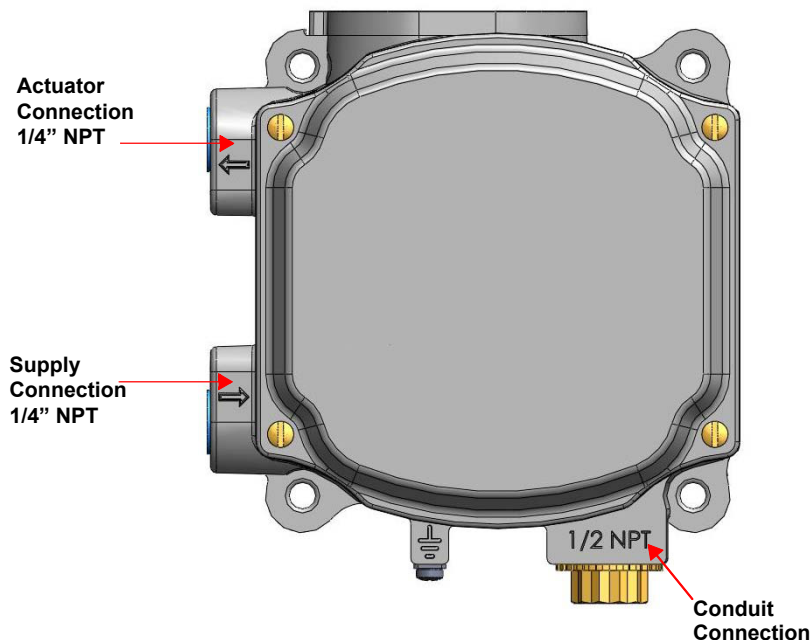

Figure 22 - Air Ports

2. Pipe the output air from the output pressure port to the actuator. Minimum tubing diameter: 1/4".

**Note: The SVi1000 is designed to operate with clean, dry, oil-free, instrument grade air to ANSI-ISA-57.3 1975 (R1981) or ISA-S7.3-1975 (R1981).**

3. Ensure the air supply falls within the parameters in Table 4.

Table 4 - Air Supply Requirements

Dew Point	At least 18° F (10° C) below minimum anticipated ambient temperature
Particulate Matter	Filtered to 5 microns
Oil Content	Less than 1 ppm w/w
Contaminants	Free of all corrosive contaminants

4. Supply clean, dry compressed air to the filter regulator.
5. Turn on the air supply.

6. Adjust the filter regulator.

Supply pressure must be a minimum of 5 psi above the spring range of the actuator but may not exceed the rated actuator pressure. Refer to the valve or actuator instruction manual.

### Step 3: Wiring the SVi1000

## **WARNING**

*Comply with current national and local regulations for electrical installation work.  
Before carrying out any work on the device, power off the instrument.*

## **CAUTION**

*Improperly or inadequately grounded installations can cause noise or instability in the control loop. The internal electronic components are isolated from ground. Grounding the case is unnecessary for functional purposes but grounding the case may be necessary to conform to local codes.*

*Refer to “Optional Switch Load Limits” on page 95 for guidelines on safely wiring switch load limits.*

### Wiring Guidelines

Guidelines for a successful implementation of DC current signal, DC power, and HART communication to the SVi1000:

- Compliance voltage at the SVi1000 is approximately 9 V at the current of 20 mA.
- Signal to the SVi1000 must be a regulated current in the range 3.2 to 22 mA.
- Controller output circuit must be unaffected by the HART tones which are in the frequency range between 1200 and 2200 Hz.
- In the frequency range of the HART tones, the controller must have a circuit impedance of more than 220 Ohms, typically 250 Ohms.
- HART tones may be imposed by the positioner and a communication device located anywhere on the signaling circuit.
- Cabling must be shielded to prevent electrical noise that would interfere with the HART tones, with the shield grounded.
- Shield must be properly grounded in only one place.
- For details and calculation methods for wiring resistance, and capacitance and for calculation of cable characteristics, refer to the HART FSK Physical Layer Specification.
- For split range installations the output voltage must be sufficient to operate two positioners (11 V @ 4 mA, 9 V @ 20 mA) and the expected voltage drop in the cable.

- Use of a low impedance voltage source damages the SVi1000. The current source must be a true high impedance current limiting device. A proper current source explicitly enables adjustment of the current, not the voltage.
- When wiring a position retransmit:
  - Use the same gauge wires as the 4-20 mA control loop.
  - Ensure that the position retransmit signal is connected to the control system's analog input card.
  - Ensure the control loop is powered while making make measurements with a meter.

## **WARNING**

*This process can cause the valve to move. Before proceeding be sure the valve is isolated from the process. Keep hands clear from moving parts.*

### **Wiring an SVi100 Unit**

Tools required:

- Wire stripper
- Flat head screwdrivers for cover and connectors

To connect:

## **CAUTION**

*For proper operation, maintain signal polarity + and - respectively.*

## **CAUTION**

*You must read "Optional Switch Load Limits" on page 95 before proceeding. The load across these switches must conform to the limits described in that discussion.*

1. Loosen the four (4) cover screws and remove the SVi1000 cover (Figure 23).

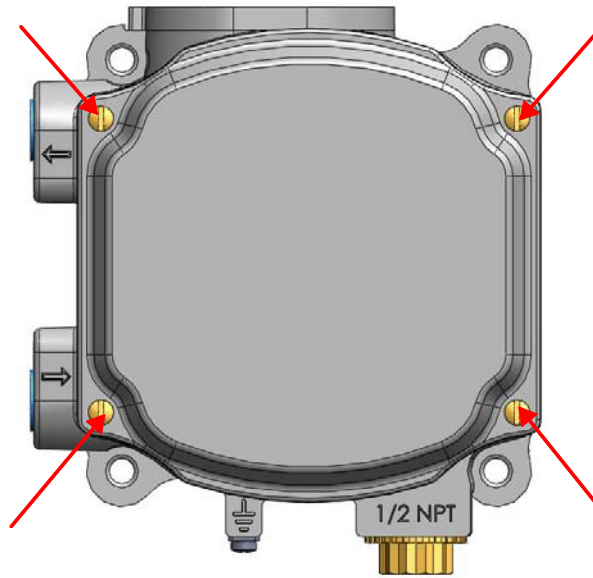

Figure 23 - Front Cover

2. Connect the 4 - 20 mA input signal and the optional switches or position retransmit by:
  - a. Stripping the insulation at the end of both wires 0.43" / 11 mm.
  - b. Inserting the stripped end of the wires fully in to the appropriate terminal. Loosen the terminal screw if required to insert the wire.

Refer to the label next to each screw terminal to determine the function of the terminal and correct polarity (see Figure 24 for 4 - 20 mA connections and Figure 25 on page 45 on for position retransmit).

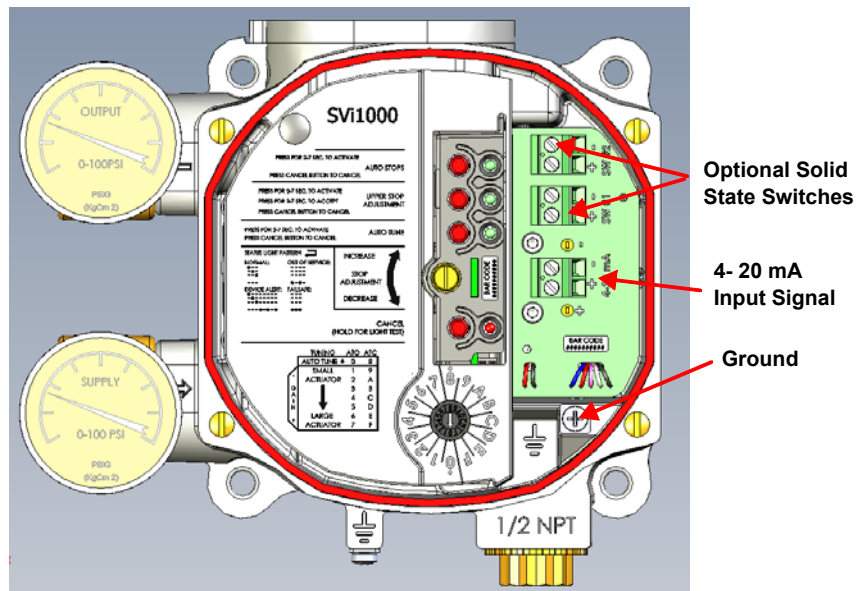
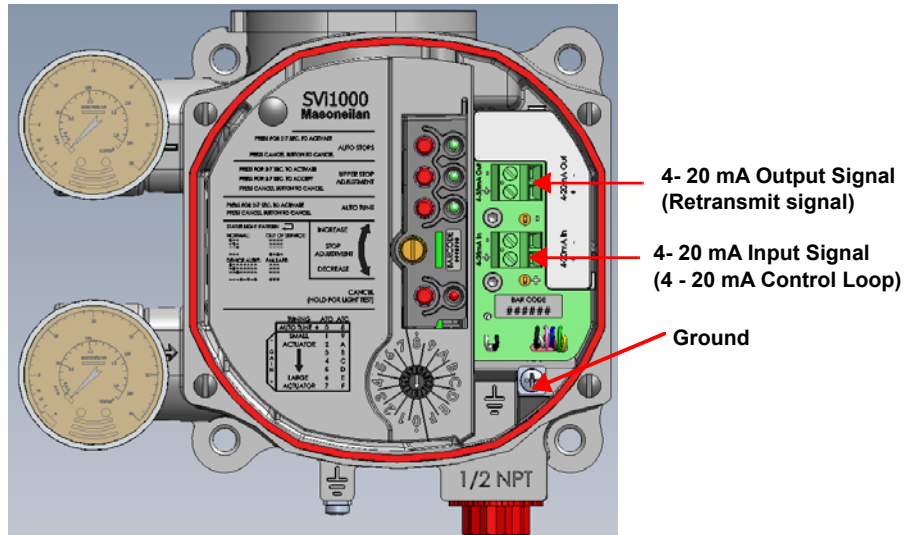

Figure 24 - Connections to Electronics Module with Switches (via Interface Board)



**Figure 25 - Connections to Electronics Module with Position Retransmit (via Interface Board)**

3. Tightening the terminal screws (to a torque of 5 to 7 lb-in).
4. Proceed to "Check Out and Power Up". Refer to "Troubleshooting Connections" if you want to check the validity of your connections.

## **Troubleshooting Connections**

### **Basic Unit/Optional Switches Unit**

To troubleshoot control loop connections:

1. Connect a DC voltmeter across the input terminals.
  - For an input current between 4 and 20 mA the voltage varies between 11V and 9 V respective.
  - If voltage exceeds 11 V check that polarity is correct.
  - If the polarity is correct but the voltage is less than 8.05 V, then the current source voltage is not compliant.
2. Verify that source can supply 20 mA to SVi1000 input. If 20 mA is not attainable, troubleshoot the source.

### **Position Retransmit Units**

To troubleshoot control loop connections:

1. Connect a DC voltmeter across the input and output terminals.
  - For an input current between 4 and 20 mA the voltage varies between 11V and 9 V respective.
  - If voltage exceeds 11 V check that polarity is correct.
  - If the polarity is correct but the voltage is less than 8.05 V, then the current source voltage is not compliant.
2. Verify that source can supply 20 mA to SVi1000 input. If 20 mA is not attainable, troubleshoot the source.

To troubleshoot retransmit connections:

- Ensure that the retransmit circuit has a minimum input voltage of 10 V (maximum 30 V).
- Ensure the minimum retransmit current is 3.2 mA. If the SVi1000 digital valve positioner loses power and the retransmit circuit remains powered, the AO signal will be 3.2 mA.

# 4. Check Out and Power Up

## Overview

This section provides the calibration procedures to ensure proper valve positioning, including:

1. “Step 1: Inspect the Actuator, Linkages, or Rotary Adapter” on page 48
2. “Step 2: Verify Mounting and Linkage Adjustment” on page 48
3. “Step 3: Checking the Magnet” on page 48
4. “Step 4: Checking the Air Supply” on page 49
5. “Step 5: Verify Wiring Connections” on page 50
6. “Step 6: Configuration” on page 51

**Note: Perform all procedures in this section before putting the SVi1000 into operation.**

## Step 1: Inspect the Actuator, Linkages, or Rotary Adapter

1. Verify that the mounting has not been damaged in shipment for a premounted SVi1000, physically inspect the actuator and linkage.
2. Record the following information for the configuration checkout:
  - Valve Air to Open (ATO) or Air to Close (ATC)
  - Actuator pressure rating
  - Actuator spring range
  - Inherent trim characteristic of the control valve; linear, equal percentage, or other.

**Note:** Refer to the valve data sheet or control valve model number.

## Step 2: Verify Mounting and Linkage Adjustment

Inspect the mounting and make any needed adjustments before running the positioner and checking the digital configuration.

## Step 3: Checking the Magnet

There are two methods of checking the SVi1000 magnet:

- “Perform a Visual Inspection” on page 48
- “Use ValVue to Check Magnet Position” on page 49

### Perform a Visual Inspection

#### Rotary Valves

Ensure that mounting has been performed as per “Step 1: Mounting the SVi1000 on Rotary Valves” on page 33.

#### Reciprocating Valves

1. Ensure the adjustable link turnbuckle is parallel to the valve stem.
2. Ensure proper mounting by verifying that the hole in the lever aligns with the alignment hole in the bracket when the valve is in the closed position. Ensure the bracket is mounted using the proper holes (see Table 3 on page 38).



## Use ValVue to Check Magnet Position

To check the magnet using ValVue:

1. Connect to the positioner in accordance with the ValVue instructions.
  - a. Ensure the positioner has been installed and set up with a HART modem in a HART compliant communications loop, if required, install ValVue on the computer that is connected to the HART modem.
  - b. Run ValVue.
  - c. Select the installed positioner from the list of connected devices.
  - d. Select the **Raw Data** tab to view the current operating conditions of the selected positioner.
2. Read Raw Position data. When the valve is:
  - Closed, the value should be between – 1000 and +1000 for a reciprocating valve or a 60° rotation rotary valve.
  - At mid-travel, the value should be between –1000 and +1000 for a greater than 60° rotation rotary valve.

## Step 4: Checking the Air Supply

To check the air supply:

1. Turn on the air supply.
2. Adjust the filter regulator.
3. Supply pressure must be a minimum of 5 psi greater than the spring range of the actuator but may not exceed the rated actuator pressure. Refer to the valve or actuator instruction manual.
4. Inspect the tubing connections between the filter-regulator and the positioner for leaks.
5. Verify that the tubing is not bent or crushed.
6. Verify that all fittings are leak tight.

### **CAUTION**

*Do not use Teflon pipe seal tape. The Teflon tape can shred into particles that are harmful to the pneumatic components.*

## Step 5: Verify Wiring Connections

**Note: For split range installations the output voltage must be sufficient to operate two positioners (11 V @ 4 mA, 9 V @ 20 mA) and the expected voltage drop in the cable. See “Split Range Applications” on page 88 for more information.**

Use the following procedure to ensure that the SVi1000 is properly powered:

1. Connect a DC voltmeter across:

- The input terminals for a basic switch or switch option unit.
- The *In* and *Out* terminals for a position retransmit unit.
  - For an input current between 4 and 20 mA the voltage varies between 11V and 9 V respectively.
  - When voltage exceeds 11 V check that polarity is correct.
  - If voltage is less than 9 V and polarity is correct, voltage compliance of current source is inadequate.

2. Connect a milliampmeter in series with the current signal.

3. Verify that source can supply 20 mA to SVi1000 input. If 20 mA is not attainable, troubleshoot the source.

**Note: Improperly or inadequately grounded installations can cause noise or instability in the control loop. The internal electronic components are isolated from ground. Grounding the case is unnecessary for functional purposes but grounding the case may be necessary to conform to local codes.**

## Step 6: Configuration

This section describes configuration using the local user interface pushbuttons and the preset switches available on the unit. You can also use ValVue and a PC with a HART modem or a HART Handheld Communicator. Prior to changing the SVi1000 configuration, check the existing configuration.

Use the procedures that follow to: run auto stops, run open stop adjustment and perform preset or auto tune.



*These procedures can cause the valve to move. Before proceeding be sure the valve is isolated from the process. Keep hands clear from moving parts.*

**Note: All calibration and configuration procedures are described using the SVi1000 local user interface. See “ValVue Software” on page 16 for an overview of ValVue software functions.**

### Auto Find Stops

To perform auto find stops:

1. Set the air action (0-7 for ATO or 8-F for ATC).
2. Press auto find stops button until green LED 1 illuminates, then release (*approximately 2 seconds to turn on and release before 7 seconds*). The unit goes into a Commission Process and green LED 1 blinks until the process completes. The auto find stops process occurs. When the process is complete, the unit automatically returns to Normal mode.

Press **Cancel** to abort the process and the green LED 1 goes off, the device returns to Normal mode and no changes occur.

## Open Stops Adjustments

To perform auto find stops:

1. Press the upper stop adjustment button for two to seven seconds, until green LED 2 illuminates, then release. Green LED 2 flashes.
2. Move the valve to the desired location via the *Open Stop Adjustment Screw* (Figure 26).

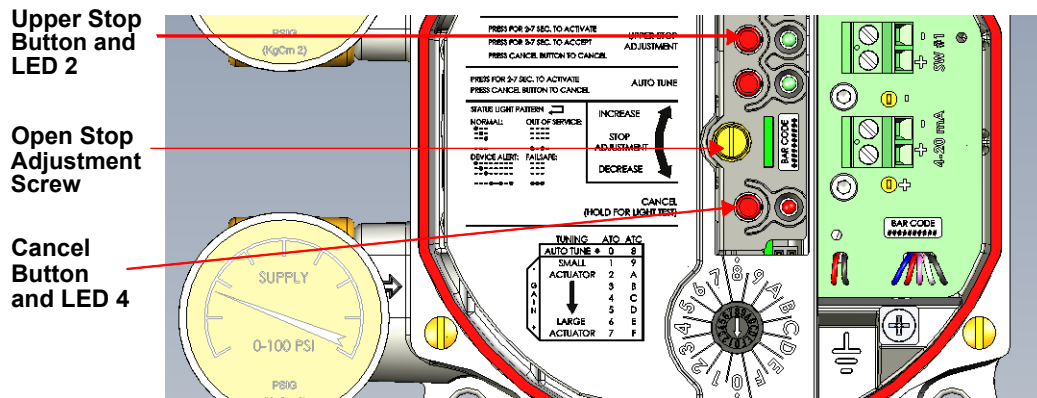

Figure 26 - Open Stop Adjustment Screw

3. Press the upper stop adjustment button for more than two seconds.

The green light goes off, the new stop is saved in the device and the unit is put into Normal mode.

Press **Cancel** to abort the process and the green LED 1 goes off, the device returns to Normal mode and no changes occur.

## Tuning

Methods for tuning the SVi1000:

- Presets; The fastest is to use a preset tuning for the actuator in use ( "Preset Tune" on page 53). Using presets saves time as you do not run Auto Tune.
- Auto Tune: If desired, run Auto Tune ( "Auto Tune" on page 55).
- PID Settings: The third method is to manually tune PID settings for fine tuning, if desired. See the online help.

## Preset Tune

Preset tuning is done according to valve/actuator size. Figure 27 shows the graphic that appears on the local user interface. As valve size increases values increase from 1 to 7 and 9 to F. 0 and 8 are reserved for auto tuning ATO and ATC valves, respectively.

Preset tuning becomes active immediately.

Gain increases as the tuning value

TUNING	ATO	ATC
AUTO TUNE ♦	0	8
SMALL ACTUATOR	1	9
↓	2	A
	3	B
	4	C
	5	D
LARGE ACTUATOR	6	E
	7	F

Figure 27 - Preset Tuning Values

To use preset tuning values:

- Use the *Configuration Selection Switch* to select a preset tuning value (Figure 28).

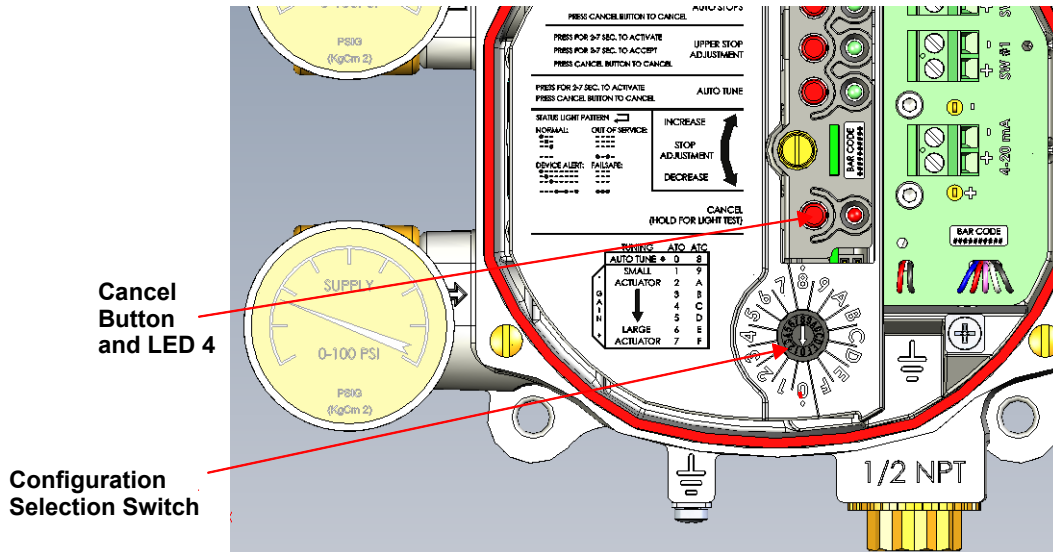



Figure 28 - Configuration Selection Switch

Table 5 gives a guideline for setting the Configuration Selection Switch with regard to actuator size.

**Table 5 - Actuator Settings Configuration Selection Switch Guidelines**

ATO	ATC	Actuator Size	Examples
1	9	 Small	1) 4.5" Camflex (7-15 SR)
2	A		2) 6" Camflex (7-15 SR)
3	B		3a) #6, 87(ATC), 3-15 SR
			3b) #6, 88(ATO), 11-23 SR
			3c) #10, 87 (ATC), 3-15 SR
			3d) #10, 88(ATO), 11-23 SR
4	C		4a) #6, 87(ATC), 6-30 SR
		4b) #6, 88(ATO), 21-45 SR	
		4c) #10, 87 (ATC), 6-30 SR	
		4d) #10, 88(ATO), 21-45 SR	
5	D	5a) #16, 87(ATC), 3-15 SR	
		5b) #16, 88(ATO), 11-23 SR	
		5c) #23, 87 (ATC), 3-15 SR	
		5d) #23, 88(ATO), 11-23 SR	
6	E	6a) 7" Camflex, 7-24 SR	
		6b) 9" Camflex, 7-24 SR	
7	F	7a) #16, 87(ATC), 6-30 SR	
		7b) #16, 88(ATO), 21-45 SR	
		7c) #23, 87 (ATC), 6-30 SR	
		7d) #23, 88(ATO), 21-45 SR	
		Large	

## Auto Tune

Auto Tune takes three to ten minutes and strokes the valve in large and small steps to set the PID positioning parameters for best response to an input signal change.

This procedure overrides any previous configuration done using presets.

To auto tune the SVi1000:

1. Set the *Configuration Selector Switch* to the auto tuning parameter (Figure 29):

- 0 for an ATO valve (Air to Open application)
- 8 for an ATC valve (Air to Close application).

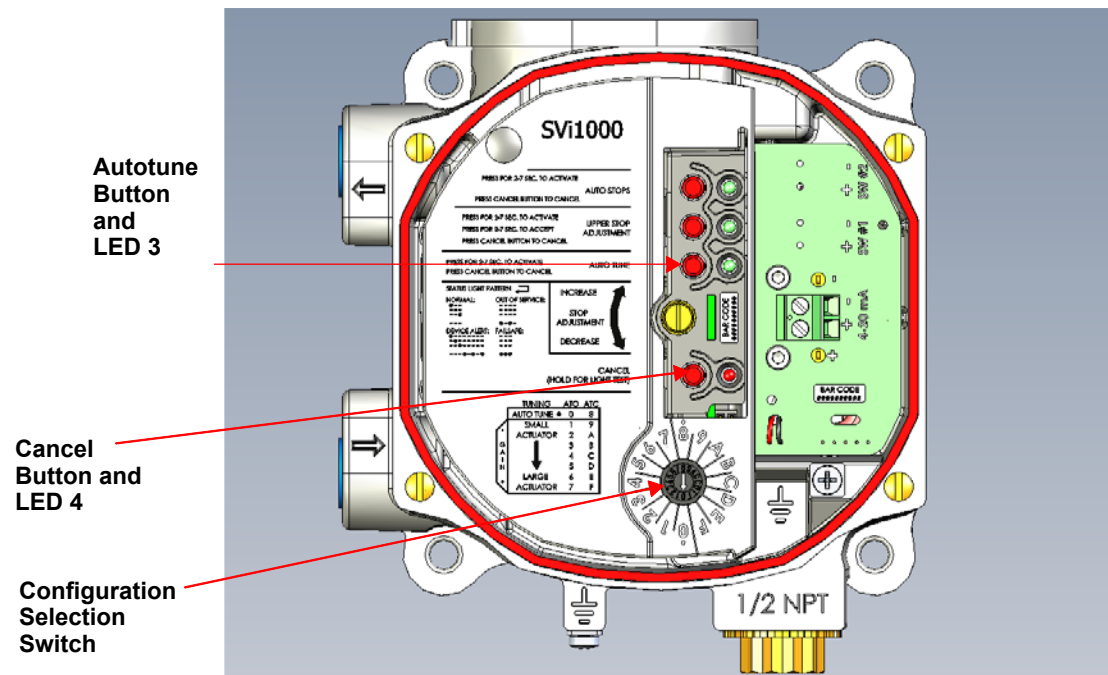

Figure 29 - Configuration Selection Switch

2. Press the **Autotune** button until green LED 3 lights, then release (*approximately 2 to 7 seconds*). The unit goes into a Commission Process and green LED 3 blinks.

When the autotune process is complete the unit automatically returns to Normal mode.

Press **Cancel** to abort the process and the green LED 3 goes off, the device returns to Normal mode and no changes to the tuning parameters occur.

## Troubleshooting Autotune

Autotune, whether using ValVue, pushbuttons (presets), a DD or a handheld, is the best way to tune the valve. If it does not work:

### Step One

Autotune again using recommended tuning parameters for the valve is use. The SVi1000 DTM help offers you instructions in how to enter these parameters in the Autotune procedure. Alternately, Try starting tuning from the 50% position. Table 6 outlines some effects of parameter changes.

**Table 6 - Rough Guide to Effects of Changing PID Values**

Parameter	Rise Time		Overshoot		Settling Time	
	Increase Value	Decrease Value	Increase Value	Decrease Value	Increase Value	Decrease Value
<i>P</i>	Decrease	Increase	Increase	Decrease	Small Effect	Small Effect
<i>I</i>	Small Effect	Small Effect	Decrease	Increase	Decrease	Increase
<i>D</i>	Small Effect	Small Effect	Decrease	Increase	Decrease	Increase

### Step Two

Run autotune again after ensuring the:

- Air supply is sufficient and there are no air leaks. Valve does not have excessive friction.
- Add some *Dead Zone* (0.25).
- Linkage is not loose or in an improper position. Mounting is installed correctly.
- Alarms are cleared. Magnet is not out of position.
- Boosters are not too aggressive. Solenoid in supply line should have a Cv that is .25 or higher.
- Is the booster by-pass valve closed? Open by-pass valve ½ turn from closed and Autotune again

### Other Issues That Affect Autotune

Valve oscillating fast:

- *P* term too high: reduce *P* by ½ and try again
- Booster too hot (aggressive) open by-pass on booster and try again

Valve oscillation slow - friction:

- Increase *I* term by 20-25%



- Add *Dead Zone* – try 0.25%

Valve moves too slowly:

- *P* term too low, try increasing by 25%
- Stroking time set to non-zero value.

*If Actuator is very large:*

Enter a typical value for *P* in the PID parameter in ValVue. SVI II AP factory value for *P* is 100; if it is a large valve this may need to be higher to start. In Setup mode enter large value for *P* and run Autotune again (See Table 6).

This page intentionally left blank.

# 5. Full Wizard

## Full Wizard Screen

From the *Full Wizard* screen you can rapidly setup the SVi1000 by configuring some basic parameters. You can set the device identification, perform a travel calibration, and autotune the positioning parameters. When the selected tasks are started a progress screen appears. To customize the valve setup refer to the Calibration Manual Tune screen in the SVi1000 DTM help. You can either run the entire wizard or pick and choose which components to run.

To run the *Full Wizard* you must first be in Setup mode.

## Full Wizard Screen

Running the *Full Wizard* is one way to set up the SVi1000. When you decide to run the setup you can either run the entire wizard or pick and choose which components to run. This wizard has the advantage of accessing diagnostics tests, which is useful for troubleshooting and during initial commissioning. If you choose not to use the *Full Wizard*, you can use the procedures it accesses to configure the following separately:

- *Calibration Range* screen to run *Find Stops* and *Open Stop Adjustment*
- *Calibration Autotune* screen
- *Calibration Manual Tune* screen
- *Calibration Calibration* screen
- Run diagnostics on the using the *Diagnostics* screen, including the step test.

The *Device Information* and *Position* fields are configurable when checked in the fields to the right.



*The valve must be Out-of-Service and isolated from the process during this process.*

# CAUTION

Procedures (e.g. Find Stops, Auto Tune, Step Test, Ramp Test) should **NOT** be invoked if the ValVue sequencer is running.

ValVue - SV1000 HART7 - Online Parameter

SV1000 HART7 - Online Parameter

SV1000 HART  
GE Oil & Gas

Tag: SV1 1000  
Active Mode: Disconnected  
Mode to Set: Normal

Device ID:  
Descriptor: SV1 1000 HART  
Final Asmby Nbr: 2009

No.	Procedure Name	Status
1	Device Information	<input type="checkbox"/>
2	Find Stops	<input type="checkbox"/>
3	Auto Tune	<input type="checkbox"/>
4	Position	<input type="checkbox"/>
5	Step Test	<input type="checkbox"/>
6	Ramp Test	<input type="checkbox"/>
7	Change Device Mode	<input type="checkbox"/>

No.	Parameter	Value
1	Tag	SV11000
2	Descriptor	SV11000 HART
3	Message	SV11000 HART
4	Date	19 JUN 2009
5	Air Action (Readonly)	Air to Open
6	Long Tag (Hart6/7 only)	SV11000

Full Wizard Graph

Position: %

Time (Sec)

Full Wizard Log

Execute Full Wizard

Figure 30 - Full Wizard Screen: Device Info

## Buttons and Fields

### Procedure Area

<b>No.</b>	Displays the number of the procedure.
<b>Procedure Name and checkbox</b>	<p>Displays the procedure as listed on the tab where fields are configured. Use the checkbox to activate the procedure for use by the wizard. The options (except <i>Change Device Mode</i>) are inactive until Setup mode is active. These options include:</p> <ol style="list-style-type: none"><li><b>1. Device Information:</b><ul style="list-style-type: none"><li>• <b>Set Tag:</b> Sets the physical device tag.</li><li>• <b>Descriptor:</b> Enter a description for the device.</li><li>• <b>Message:</b> Enter a device-related message.</li><li>• <b>Date:</b> Enter date the device placed in service, etc.</li><li>• <b>Air Action:</b> Displays the device air action that is factory set.</li><li>• <b>7 Long Tag (HART 6/7 only):</b> Enter a tag for a HART 7 device. This appears only if connected to a HART 7 device.</li></ul></li><li><b>2. Find Stop:</b> Runs all <i>Find Stops</i> operations. Click <b>Edit Settings</b> to open the <i>Calibration Range</i> screen to configure settings.</li><li><b>3. Auto Tune:</b> Runs all <i>Auto Tune</i> procedures, including; <i>Aggressiveness</i> and <i>Supply Pressure</i>. See <i>Calibration Autotune</i> screen in <i>Masoneilan SVi1000 DTM Software Instruction</i> manual (Ref. 31427).</li><li><b>4. Position:</b> Sets the position related parameters as described on the <i>Configuration Position</i> screen in <i>Masoneilan SVi1000 DTM Software Instruction</i> manual (Ref. 31427).</li><li><b>5. Step Test:</b> Runs a <i>Step Test</i>. See <i>Diagnostics Start Step Test</i> in <i>Masoneilan SVi1000 DTM Software Instruction</i> manual (Ref. 31427).</li><li><b>6. Ramp Test:</b> Runs a <i>Ramp Test</i>. See <i>Diagnostics Start Ramp Test</i> in <i>Masoneilan SVi1000 DTM Software Instruction</i> manual (Ref. 31427).</li><li><b>7. Change Device Mode:</b> Changes the positioner to mode selected in the <i>Apply Mode</i> field.</li></ol>

**Status** Displays a progress bar during execution for each selected item.

**Check All** Click the checkbox to select/deselect all *Procedure Name* items.

### Parameter Area

**No.** Displays a number for each parameter associated with the *Procedure Name* selected in the procedure area.

**Parameter** Lists the parameters associated for the *Full Wizard* for the *Procedure Name* selected.

**Value** Lists the parameter value read from the tab where it is configured.

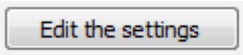
 Edit the settings

*Edit the settings*  
button

Click the button and you are taken to the tab where the values are input. Return to the *Full Wizard* tab to continue the process.

**Full Wizard Graph** Displays a graph of % (percentage of the procedure complete) vs. *Time with Supply*

### General Graph functionality

All graphs have some common functionality, including:

- Click-and-hold on any axis' legend to drag along the axis.
- Press the **CTRL** button and mouse drag to zoom/unzoom on the graph.
- Right-click menu: There is a menu available by right-clicking any axis that has three selections:
  - *Tracking Enabled*: Enables/disables tracking.
  - *Update Resume Values*: Store the axis scale for the *Tracking Enabled*. The next time *Tracking Enabled* is engaged, the tracking restores the axis to the stored scale instead the initial scale.
  - *Zoom to Fit*: Activates a function that sizes the graph to fit the selected display area.

### Full Wizard Log

Displays basic information about test run time and device, along with test-related messages and outcome.



Click to begin execution of configured items.

*Execute Full Wizard*  
button

## Run the Full Wizard

To run the Full Wizard:

1. Set the *Current Slot* to either 0 for ATO or 8 for ATC.



*This procedure moves the valve.*

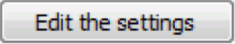

*Procedures (e.g. Find Stops, Auto Tune, Step Test and Ramp Test) should **NOT** be invoked if the ValVue sequencer is running.*

1. Place the system in *Out of Service* mode.
2. Click an item in the *Procedure Name* list or click **Check All**.
3. Click and individual line in the *Procedure Name* list and the items related to that appear in the *Parameter Area*.
4. Click  and the tab related to the settings appears.

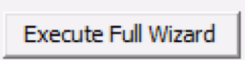
5. Enter values into fields as required.
6. Repeat steps 3, 4 and 5 as required.
7. Click  and the wizard commences.

This page intentionally left blank.



# 6. Operation and Maintenance

## Principle of Operation

The SVi1000 Electro Pneumatic Valve Positioner receives an electrical position setpoint signal from a controller or other device and compares the position setpoint input signal to the valve position. The difference between the position setpoint and position feedback is interpreted by the position control algorithm. This is used to compute a new output pressure. This output pressure is amplified by a pneumatic relay that drives the actuator. When the valve position agrees with the value called for by the position setpoint input signal the system stabilizes with no further movement of the actuator.

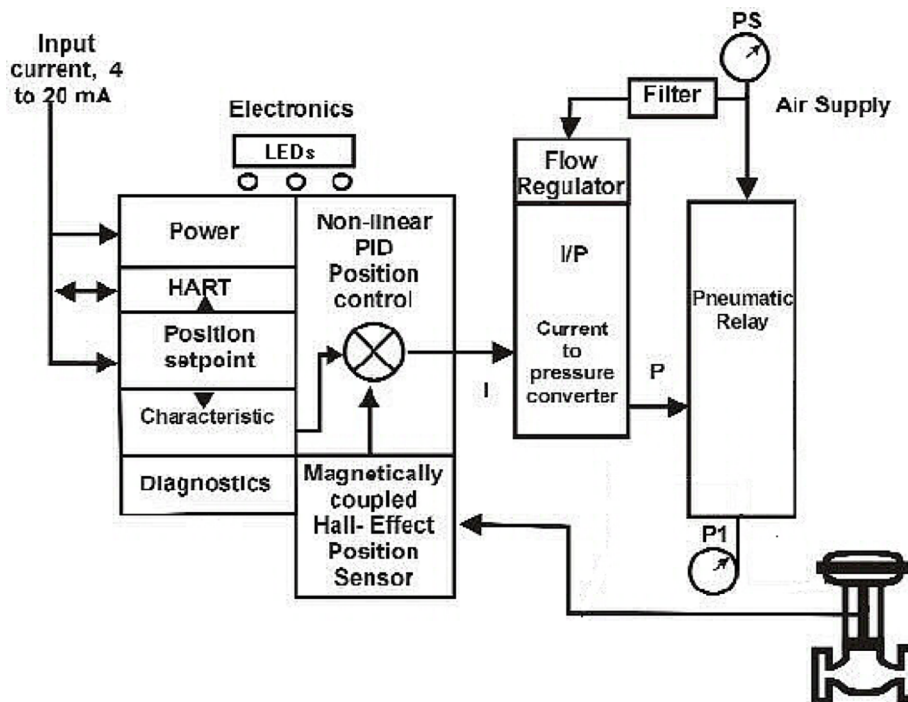

Figure 31 - Block Diagram with I/P Converter

# Physical and Operational Description

The SVi1000 is housed in an industrial, tough, weatherproof, corrosion resistant polycarbonate housing. Electrical connections are made through a 1/2" NPT conduit entry. Pneumatic connections are made through two or three 1/4" NPT ports.

## Electronics Module

The Electronics module consists of an electronic circuit encapsulated in a housing. The electronics include a multiplexer, A/D, D/A, temperature sensor, Hall-Effect magnetic position sensor, pressure sensors, a micro controller, and a power management/distribution circuit. The programs controlling the SVi1000 digital valve positioner are stored in a flash memory that allows for the downloading of upgraded firmware.

A separate non-volatile memory stores configuration information, and continuous diagnostic results. Expansion capabilities include two digital software switches and manifold gauges. Using the internal programmed positioner algorithm, the CPU computes the required output based on information received from the measurement sensors.

## Magnetic Position Sensor

A non-contact sensor uses a magnetic field to transfer the position through the wall of the housing, without penetration, to sense the valve position. A Hall effect device, sealed within the electronics housing, senses the rotation of a magnetic assembly mounted on the end of a rotary valve shaft or on a driven linkage mounted on a reciprocating valve.

The output of the Hall sensor provides the position feedback signal to the position control algorithm. The magnetic assembly is environmentally sealed and is entirely external to the electronics housing. (See Figure 31 on page 65.) The Hall effect sensor has a maximum travel range of up to 140° rotation.

## Position Retransmit

The position transmission option provides a 4 - 20 mA signal proportional to valve position transmitted on a separate pair of leads.

The 4-20 retransmit signal is galvanically isolated from the 4-20 input on the main board.

## Temperature Sensor

A temperature sensor is located in the electronics module and measures ambient temperature. This measurement is used to provide temperature compensation for the position and pressure sensors and other internal electronic components. The temperature is read via the HART communication link to provide a warning of excessive ambient temperature at the positioner.

## Pneumatic Module

The pneumatic module consists of an I/P and Relay assembly.

### Current-to-Pressure Converter, I/P

The I/P converts a current signal in the following manner:

1. A fixed coil creates a magnetic field proportional to the applied current.
  2. The field magnetically pulls a flexure towards a nozzle to increase pressure on the flexure.
  3. The pressure on the flexure increases in response to an increase in the coil current.
- Encapsulation of the coil provides protection from the environment.

### Single Acting Pneumatic Relay

The single acting pneumatic relay amplifies the pressure from the I/P and increases airflow as required for stable, responsive, actuator performance. The single acting relay operates on any supply pressure that is at least 5 psi (.345 bar, 34.5 kPa) above the required actuator pressure, up to 100 psi (6.9 bar, 690 kPa).

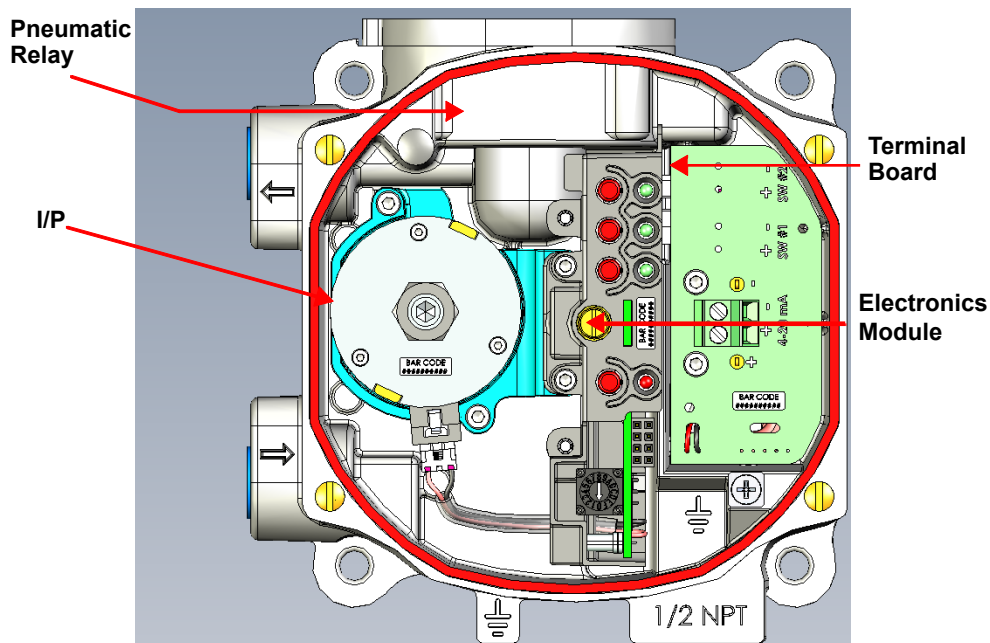

Figure 32 - Pneumatic Module

# SVi1000 Maintenance and Repair

## Adjusting I/P Zero

The I/P Zero is calibrated at the factory prior to shipment. If there is a problem with I/P zero please contact your Masoneilan representative.

## Repair by Replacement

Using ValVue and repair-by-replacement is the fastest method to service an SVi1000. See the ValVue SVi1000 DTM software instruction manual or help for details regarding uploading and downloading configuration files. Upload all configuration information from the installed positioner to ValVue, then install the replacement positioner and download the configuration file into the replacement unit. Run STOPS, and AutoTune, and the repair is complete. The positioner that was removed can be refurbished and reused.

**Note: Substitution of components can void safety approvals.**

A series replacement kits are available and are listed in “Spare Parts” on page 74. Each of these kits comes with a procedure for completing the replacement.

## Internal Diagnostics

The SVi1000 performs internal self-diagnostics and hardware checks. When ValVue or HART Handheld or the local display indicates that there are error messages write them down for troubleshooting.

## FAILSAFE Mode

Several of the internal diagnostics tests puts the SVi1000 into FAILSAFE mode if the errors continue for a preset time. When the SVi1000 goes into FAILSAFE, the valve is driven to its Failsafe position. It remains in that position until the positioner automatically clears the cause of the error and resets the instrument.

## Upgrading Firmware

The SVi1000 is equipped with a nonvolatile re-writable Flash Memory for program storage. The firmware can be updated as improvements and advances are made in the embedded programs that operate the SVi1000. Firmware improvements for the SVi1000 can be obtained by contacting the factory.

# 7. Specifications, Spare Parts and References

## Physical and Operational Specifications

This section provides the physical and operational specifications for the SVi1000. Specifications are subject to change without notice.

**Table 7 - Environmental Specifications**

Parameter	Storage & Transport (Packaged)
Operating Temperature Limits	-40 °F to 185 °F (-40 °C to 85 °C)
Storage Temperature Limits	-58 °F to 200 °F (-50 °C to 93 °C)
Temperature Effect	< 0.005% / °F typical; -40 °F to 180 °F (< 0.01% / °C typical; -40 °C to 82 °C)
Supply Pressure Effect	0.05% per psi (.73% per bar)
Operating Relative Humidity	5 to 100% non-condensing
Storage Relative Humidity	0 to 100% non-condensing
Humidity Effect	Less than 0.2% after 2 days at 104 °F (40 °C), 95% Relative Humidity.
Electromagnetic Compatibility Electrostatic	IEC 61514 Industrial-Process Control systems - methods of evaluating the performance of intelligent valve positioners with pneumatic outputs. IEC 61326 Electrical equipment for measurement, control and laboratory use - EMC requirements.
Fast Transient Burst	No effect at 2 kV (Coupling clamp EN61000-4-4 or IEC1000-4-4).
Housing	Tropicalized with positive pressure
Vibration Influence Measured at SVi1000 Housing	4 mm at 5 - 15 Hz - Negligible 2 G at 15 - 150 Hz Less than 2% of span 1 G at 150 - 2000 Hz - Less than 2% of span
Magnetic Field Influence	Negligible at 100 A/m 50/60 Hz (EN61000-4-8) CE MARK The SVi1000 conforms to the requirements of the ATEX 94/9/EC and EMC 2014/30/EU directives.

**Table 8 - Operational Specifications**

Accuracy	+/- 1.0% (typical or less) Full Span
Hysteresis and Deadband	+/- 0.3% Full Span
Repeatability	+/- 0.3% Full Span
Conformity	+/- 0.5% Full Span
Start-Up Drift	Less than 0.02% in first hour
Long Term Drift	Less than 0.003% per month
Position Travel Limits	Rotary: 18 - 140° Reciprocating: 0.25" - 2.5" (6 mm - 64 mm) <i>Note: Above 2.5" (64 mm) consult factory for mounting instructions.</i>
Tight Shut Off	0 -20% of input
Flow Characteristics Applied in addition to the con-trol valve's inherent characteristic.	Linear Equal Percentage (of 50:1 or 30:1) Camflex Quick Opening (inverse of 50:1 equal percentage) User Configurable
Position Auto Tune SVi1000 performs automatic determination of the optimal valve position control parameters. In addition to P, I, D, the position algorithm uses damping, symmetry for exhaust and fill time constants, dead zone and magnitude characterization parameters. Auto Tune is optimized for 5% step changes with negligible overshoot. After the Auto Tune process is completed, the user can further adjust the positioner tuning parameters to more conservative or to more responsive values.	Proportional gain: 0 to 5000 Integral time: 0 to 100 seconds - displayed as 0 to 1000 (1/10s) Derivative time: 0 to 200 ms Dead Zone: 0 to +/-5% (0 to 10% deadband) Padj: +/- 3000 (depends on P) Beta (non-linear gain factor): -9 to +9 Position compensation coefficient: 1 to 20 Boost: 0 to 20
Stroking Time	0 to 250 seconds
Full open position adjustment	60 to 100% of actual travel
Start Up Time (from no power)	Less than 500 ms
Minimum current to maintain HART	3.4 mA
HART Command#3 Mapping	PV= Valve Position, 0-100% SV = N/A TV = Reserved QV = Reserved

**Table 9 - Input Signal and Power, Specifications**

Power Supply	Loop powered from 4-20 mA control signal
Compliance Voltage Rating	9.0 V at 20 mA, 11.0 V at 4.0 ma
Minimum Current Signal to Start Up	3.2 mA
Minimum Input Span for Split Range Operation	5 mA
Upper Range Value for Split Range Operation	8 mA to 20 mA
Lower Range Value for Split Range Operation	4 mA to 14 mA
Wire Size	12/28 AWG
Strip Length	0.43 in / 11 mm
Digital Communication	HART Communication protocol revision 5 (firmware version 2.2.1) and 7 (firmware version 3.1.1).

**Table 10 - Construction Material Specifications**

Housing and Cover	Low Copper Aluminum Alloy
Weight	SVi1000: 3.2 lbs./ 1.451 kg SVi1000 SW/G/IM: 4.1 lbs./ 1.860 kg
Relay	Nitrile diaphragms, Polycarbonate
I/P Motor	430 stainless steel, Low Copper Aluminum Alloy, 300 series stainless steel, nitrile diaphragm
Magnet Holder	Corrosion Protected Anodized Aluminum 6061 T6
Pole Ring	416 stainless steel
Levers	300 Series stainless steel

**Table 11 - System Connectivity**

HART Physical Device Type	Positioner; HART cmd rev 5 or 7, Device type 204 (0x00cc)
DD Registered with Field Comm® Group	Yes
Integration with HART Host software	ValVue standalone, ValVue AMS SNAP-ON application available, Plug-In Application For Yokogawa™ PRM, ValVue For Honeywell™ FDM™, Device Type Manager (DTM) for FDT Host

**Table 12 - Pneumatics Single Acting Standard Flow**

Air Supply	Dry, oil-free, 5 micron filtered air (per ISA S7.3)
Action	Direct Acting
Supply Pressure	15 to 100 psi max. (1.03 to 6.9 Bar) Regulate 5 psi (.34 Bar) minimum above actuator spring range. Do not exceed actuator rating.
Air Delivery	6.1 scf/min. (283 L/min.) at 30 psi (2.1 bar) supply 8.7 scf/min. (470 L/min.) at 60 psi (4.2 bar) supply 11 scf/min. (660 L/min.) at 90 psi (6.3 bar) supply
Air Capacity (flow coefficient)	Loading CV = 0.30 Venting CV = 0.40
Air Consumption	0.19 scf/min. (5.4 L/min.) at 30 psi (2.1 bar) supply 0.30 scf/min. (8.5 L/min.) at 60 psi (4.2 bar) supply 0.40 scf/min. (11.4 L/min.) at 90 psi (6.3 bar) supply
Air Supply Failure	On supply failure the actuator output fails to atmosphere. Some overshoot may occur when air pressure returns after a period without air supply pressure.
Loss of Input Signal	Actuator Output fails to atmosphere
Output Pressure	0-100 psi (6.9 bar) max

**Table 13 - SVi1000 Model Numbering**

Model Number	Configuration
SVi1000	Assembly
SVi1000 /SW	Assembly with switches
SVi1000 /G	Assembly with gauges
SVi1000 /SW/G	Assembly with switches and gauges
SVi1000 /PR	Assembly with position retransmit
SVi1000 /PR/G	Assembly with position retransmit and gauges
<b>With Integrated Magnet</b>	
SVi1000 /IM	Assembly with integrated magnet
SVi1000 /G/IM	Assembly with gauges and integrated magnet
SVi1000 /SW/IM	Assembly with switches and integrated magnet
SVi1000 /SW/G/IM	Assembly with switches, gauges and integrated magnet
SVi1000 /PR/IM	With position retransmit and integrated magnet
SVi1000 /PR/G/IM	With position retransmit, gauges and integrated magnet



**Table 14 - HART Device Information<sup>1</sup>**

<b>Item</b>	<b>Definition</b>
Model Name	SVi1000
Device Type Code	239 or 0xEF (firmware 3.1.1) 204 or 0x00cc (firmware 1.1.1 or 2.2.1)
Device Revision	1 if firmware 3.1.1 1 for firmware 1.1.1, 2 for firmware 2.2.1
HART Protocol Revision	Firmware 2.2.1 /3.1.1 (HART 5/HART 7 switchable) Firmware 2.2.1 (HART 5)
Number of Device Variables	20 (in HART 7 for firmware 3.1.1)
Physical Layers Supported	FSK
Physical Device Category	Digital Valve Positioner, Non-DC-isolated Bus Device

<sup>1</sup> Devices carrying firmware 3.1.1 can switch between HART versions to operate the device in HART 5 (2.2.1) or HART 7 (3.1.1).

# Spare Parts

Spare part kits available include:

- SVi1000 Position Retransmit Main Electronics Assembly and Terminal Board (Part Number 720045089-999-000)
- SVi1000 I/P Replacement (Part Number 720045087-999-000)
- SVi1000 Housing Cover Replacement (Part Number 720045085-999-000)
- SVi1000 Position Retransmit Terminal Board Electronic Assembly (Part Number 720045084-999-000)
- SVi1000 Switch Terminal Board Electronic Assembly (Part Number 720045083-999-000)
- SVi1000 Main Electronics Assembly (Part Number 720045081-999-000)
- SVi1000 Basic Terminal Board Electronics Assembly (Part Number 720045082-999-000)
- SVi1000 Pressure Gauges Mounting (Part Number 720023182-999-0000)
- Integral magnet assembly (Part Number 720044034-999-0000)

## Notes on Retransmit Board Upgrade Requirements

SVi1000s with serial numbers beginning with N (red box in Figure 33).



Figure 33 - Newer Serial Numbers

Newer serial number SVi1000s with the basic electronics are field upgradeable. If you purchased an with a basic terminal board, to upgrade to a retransmit or switch option terminal board, you need to order a only new terminal board assembly.

To upgrade, order and replace only:

- 720045084- 999-000: SVi1000 Position Retransmit Terminal Board Electronic Assembly

SVi1000s with serial numbers beginning with M (red box in Figure 34).



Figure 34 - Older Serial Number

To upgrade, order and replace:

720045089-999-0000: Contains a Main and a Terminal Board.

# Preparing to Contact Customer Support or Product Return

Fill out the two page form below before contacting support or before return shipment.

Baker Hughes

Masoneilan Products

<b>Digital Products Material Return Authorization</b>			
<b>Technical Support</b>		Phone Number +1 888-784-5463 Email Address <a href="mailto:svisupport@bakerhughes.com">svisupport@bakerhughes.com</a>	
<b>MRA Guidelines</b>		Complete the following Material Return Authorization Questionnaire. Email the form to the SVI Help Desk Representative for an MRA Number. Decontaminate the unit and provide an MSDS (Material Safety Data Sheet).	
FIRT #: _____ / MRA #: _____			
<b>Warranty Claimed</b>		YES	NO
		<input type="checkbox"/>	<input type="checkbox"/>
1	Date:	Authorized By:	Original Sales Order:
2	Plant of Origin	Jacksonville <input type="checkbox"/>	Deer Park <input type="checkbox"/> Other <input type="checkbox"/>
3	Product	Other: _____ <input type="checkbox"/>	FVP <input type="checkbox"/> SVI II AP <input type="checkbox"/>
		SVI1000 <input type="checkbox"/>	SVI II ESD <input type="checkbox"/> SVI FF <input type="checkbox"/>
4	Part Number:	Serial Number:	
5	With Display	<input type="checkbox"/>	Remotely Mounted <input type="checkbox"/>
6	Dates in Service:	Date of Field Issue:	
7	Actuator	Masoneilan <input type="checkbox"/>	Model Size
		Other _____ <input type="checkbox"/>	
8	Spring Range:	Air Supply - Pressure / Dew point: /	
<b>Sales Representative Information</b>		<b>End User Information</b>	
9	Sales Rep. Name	Company Name	
	Address	Address	
	Contact	Contact	
	Phone	Phone	
<b>Field Issues</b>			
10	<b>Troubleshooting Guide Complete</b>	<input type="checkbox"/>	Find Stops Failed <input type="checkbox"/>
	No Communication Go to page 2:	<input type="checkbox"/>	Auto Tune Failed & Manual Tuning Failed <input type="checkbox"/>
	No Communication using a Handheld	<input type="checkbox"/>	Unstable Output (Cycling) <input type="checkbox"/>
	No Pneumatic Output	<input type="checkbox"/>	Output Saturated to Supply <input type="checkbox"/>
	SVI Display Functional	<input type="checkbox"/>	Unit in Failsafe Mode <input type="checkbox"/>
	Erratic Valve Positioning	<input type="checkbox"/>	Failsafe Fault _____
11	<b>Additional Information:</b>		
12	<b>Warranty Authorized By:</b>	<b>Estimated Warranty Cost:</b>	
	<b>Authorized By:</b>	<b>Date:</b>	

Details of Field Issue: No Communication

Did not communicate with what?

Handheld

PC running software? What software

DCS running what software? DCS type: \_\_\_\_\_ Software: \_\_\_\_\_

Please send picture of wiring used for communication

FF details:

SVFI FF bus address in physical SVI FF: \_\_\_\_\_ Bus Address for SVI FF in DTM or DCS: \_\_\_\_\_

For Handheld, what type handheld? What is DD version in handheld: \_\_\_\_\_

Was SVI sold on a new control valve built at Baker Hughes factory? [ ] Yes [ ] No. If Yes:

Name of factory: \_\_\_\_\_

Valve ship date: \_\_\_\_\_

Valve serial number: \_\_\_\_\_ Valve Tag Number: \_\_\_\_\_

Sales Order for control valve: \_\_\_\_\_

Please provide spec sheet for control valve

End user Information on page 1:

Was positioner shipped from Baker Hughes un-mounted: [ ] Yes

Name of Baker Hughes location that shipped positioner: \_\_\_\_\_

Did rep mount positioner on control valve and ship control valve with SVI II AP? Provide control valve details as well as date of first use for SVI II AP. SVI II AP date of first use is date when selected from rep stock and mounted on control valve at rep. Also provide date when control valve was put into service by customer.

Include:

- Positioner configuration report from ValVue software.
- ValVue 2-way 25% step test diagnostic report.
- Installation ambient min/max temperatures when field issue occurred.
- Photographs of installation (show entire control valve).
- ValSpeQ file for new control valve or ValKeep record for repaired valve.

If SVI is standard diagnostic version, also run manual step test and fill out below "Tested Positioner" table:

Expected - Good Positioner			Tested positioner s/n _____		
mA signal	Valve Position	P1	mA signal	Valve Position	P1
0	open	0	0		
4	open	0	4		
8	25% closed	10	8		
12	50% closed	12	12		
16	75% closed	15	16		
20	100% closed	20	20		
16	75%	15	16		
12	50%	12	12		
8	25% closed	10	8		
4	100% open	0	4		

This page intentionally left blank.

# 8. Using the Digital Interfaces

## Overview

This section describes the ways to communicate, configure, and calibrate the SVi1000. You can:

- Streamline the valve positioning function
- Improve precision of process control
- Communicate critical information locally and remotely

The four available communication tools listed below offer increasing levels of functionality.

- Local User Interface and LEDs. See “Functionality” on page 19.
- “Hand Held Communicator” on page 81
- “ValVue Software” on page 85
- Any HART capable Host loaded with the DD for the SVi1000.

## Notes on Aggressiveness

### Setting Aggressiveness

While the SVIi1000 DTM and the DD allow you to set Aggressiveness, the pushbuttons do not. In all three methods, however, the Aggressiveness value is inherited from any previously performed tuning (Autotune or manual). Once Aggressiveness, and other tuning values are determined, they are stored in NVRAM.

The SVI1000 provides a user define Aggressiveness Level for auto-tuning, the allowable range varies from -9 to +9 where 0 (Zero) is consider normal tuning. The Aggressiveness Level influences stroking speed and over-shoot. A negative value will SLOW stroking speed and help minimized over-shoot. A positive value will INCREASE stroking speed and may add some over-shoot. The recommended values for Aggressiveness is 0 for control valves with-out volume boosters.

In applications with volume boosters and/or quick exhaust valves are used the Aggressiveness Level is not as influential. For Auto-tuning it is usually between 0 and 3. Reduce the volume boosters sensitivity by opening the integral bypass needle valve about 1 to 2 turns. Use caution when adjusting the needle valve so as to not to damage the seat, close gently to seat and then open 1 or 2 turns.

### Aggressiveness Dynamic

Lower values of aggressiveness lead to lower PID values and slower response and less overshoot.

Higher values lead to higher PID values and quicker response and more overshoot.

Once you have a preferred aggressiveness and you tune once, all future autotunes automatically use that same value, until user-changed.



# Hand Held Communicator

The HART handheld communicator is a universally available tool that provides all the accessibility of the local user interface. The HART tool has the functionality to upload and download configurations, enter alphanumeric messages and set the custom characteristic numerical parameters. The GE DPI620, used as an example here, is approved for Intrinsically Safe use in Hazardous Areas in accordance with SVi1000 Approvals and in accordance with the HHC approvals. Additionally, you can use Emerson 475, Fluke 774, SMAR HPC301 or Merram 4X00.

For communication to a HART device, there is a Device Description Language. A Device Description, DD, is published by registration with the Field Comm® Group. When the DD is installed in a host communication device then the host can readily access all the information in the smart field device. The SVi1000 registered DD will be available from Field Comm® Group when it next publishes the HART DD.

While the SVi1000 is equipped with a local user interface, checkout and configuration can also be performed using the standard HART communications interface.

Connect the HART Handheld Communicator (HHC) to the SVi1000 as shown in Figure 35. Refer to the HART Communicator product manual included with the HHC or other HARTv Communication devices.

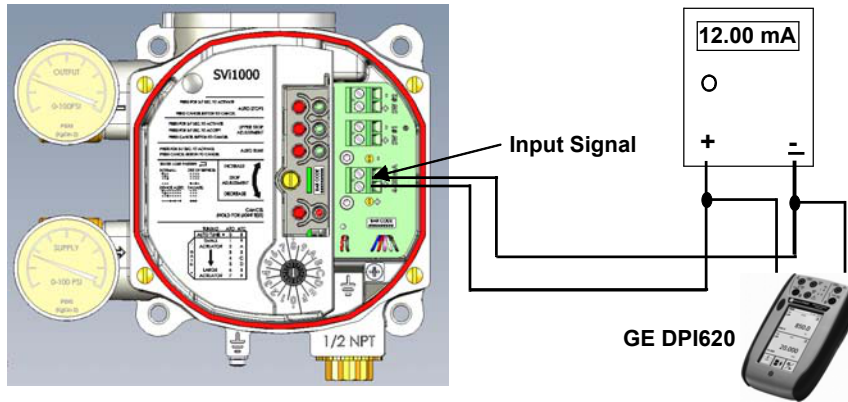

Figure 35 - SVi1000 HART Communicator Connections

# SVi1000 HART Commands

Table 15 - SVi1000 HART Commands

Command	Description
Command 0	Read Unique Identifier
Command 1	Read Primary Variable
Command 2	Read Current
Command 3	Read Dynamic Variables
Command 6	Write Polling Address
Command 7	Read Loop Configuration
Command 8 (HART 7 only)	Read Variable Classifications
Command 9 (HART 7 only)	Read Device Variables with Status
Command 11	Read Unique Identifier By Tag
Command 12	Read Message
Command 13	Read Tag and Descriptor
Command 14	Read PV Transducer Information
Command 15	Read Device Information
Command 16	Read Assembly Number
Write Message	Write Message
Command 18	Write Tag and Descriptor
Command 19	Write Assembly Number
Command 20 (HART 7 only)	Read Long Tag
Command 21 (HART 7 only)	Read Unique Identifier associated with Long Tag
Command 22 (HART 7 only)	Write Long Tag
Command 33	Read Device Variables
Command 35	Write PV Range
Command 38	Reset Configuration Change Flag
Command 42	Reset
Command 48	Read Additional Device Status See Table 16 for return bits information.
Command 54	Read Device Variable Info
Command 105 (HART 5 only)	Read burst configuration
Command 107 (HART 5 only)	Write burst device variables
Command 108 (HART 5 only)	Write Burst Mode Command
Command 109 (HART 5 only)	Write Burst Mode Control
Command 128	Read Variable Address
Command 223	Write HART Revision

**Table 16 - Command 48 Additional Status Return Bits**

<b>Byte/Bit</b>	<b>Definition</b>	<b>Byte/Bit</b>	<b>Definition</b>
0/0	Reset	4/0	Reference voltage error
0/1	Low power	4/1	Position sensor error
0/2	Actuator error	4/2	Current sensor error
0/3	Low air supply	4/3	Temperature sensor error
0/4	Position error	4/4	N/A
0/5	N/A	4/5	N/A
0/6	Keypad error	4/6	N/A
0/7	Marginal power	4/7	N/A
1/0	Calibration failed	5/0	I/P pressure sensor error
1/1	Find stops failed	5/1	Atmospheric pressure sensor error
1/2	Autotune failed	5/2	N/A
1/3	N/A	5/3	FRAM write error
1/4	Read Device Information	5/4	IRQ fault
1/5	RTOS scheduling	5/5	N/A
1/6	N/A	5/6	Self-check fault
1/7	N/A	5/7	Software error
2/0	Bias out of range	6/0	Terminal module identification error
2/1	N/A	6/1	Terminal module data integrity error
2/2	N/A	6/2	N/A

**Table 16 - Command 48 Additional Status Return Bits (Continued)**

<b>Byte/Bit</b>	<b>Definition</b>	<b>Byte/Bit</b>	<b>Definition</b>
2/3	N/A	6/3	N/A
2/4	N/A	6/4	N/A
2/5	N/A	6/5	N/A
2/6	N/A	6/6	N/A
2/7	Auxiliary memory fault	6/7	N/A
3/0	FRAM checksum error		
3/1	RAM checksum error		
3/2	Flash checksum error		
3/3	Stack error		
3/4	Factory write		
3/5	FRAM test		
3/6	N/A		
3/7	Factory mode		

## ValVue Software

ValVue Software combines the power of the PC with the features of the SVi1000 DTM software for ease of use and automation of positioner operation and full access to all data. See “SVi1000 DTM Full Wizard” on page 57 for further information. ValVue is used to configure and calibrate valves with the SVi1000 utilizing HART communications protocol.

See “ValVue and SVi1000 DTM Software Installation” on page 27 for download and installation instructions. For assistance contact the nearest Masoneilan Sales Office, your local Masoneilan representative or email [svisupport@bakerhughes.com](mailto:svisupport@bakerhughes.com).

# SVi1000 DD Navigation

HART DD - SVi1000 (Applicable to Firmware 2.2.1 (HART 5) or 3.1.1 (HART 7) and DD version 1)

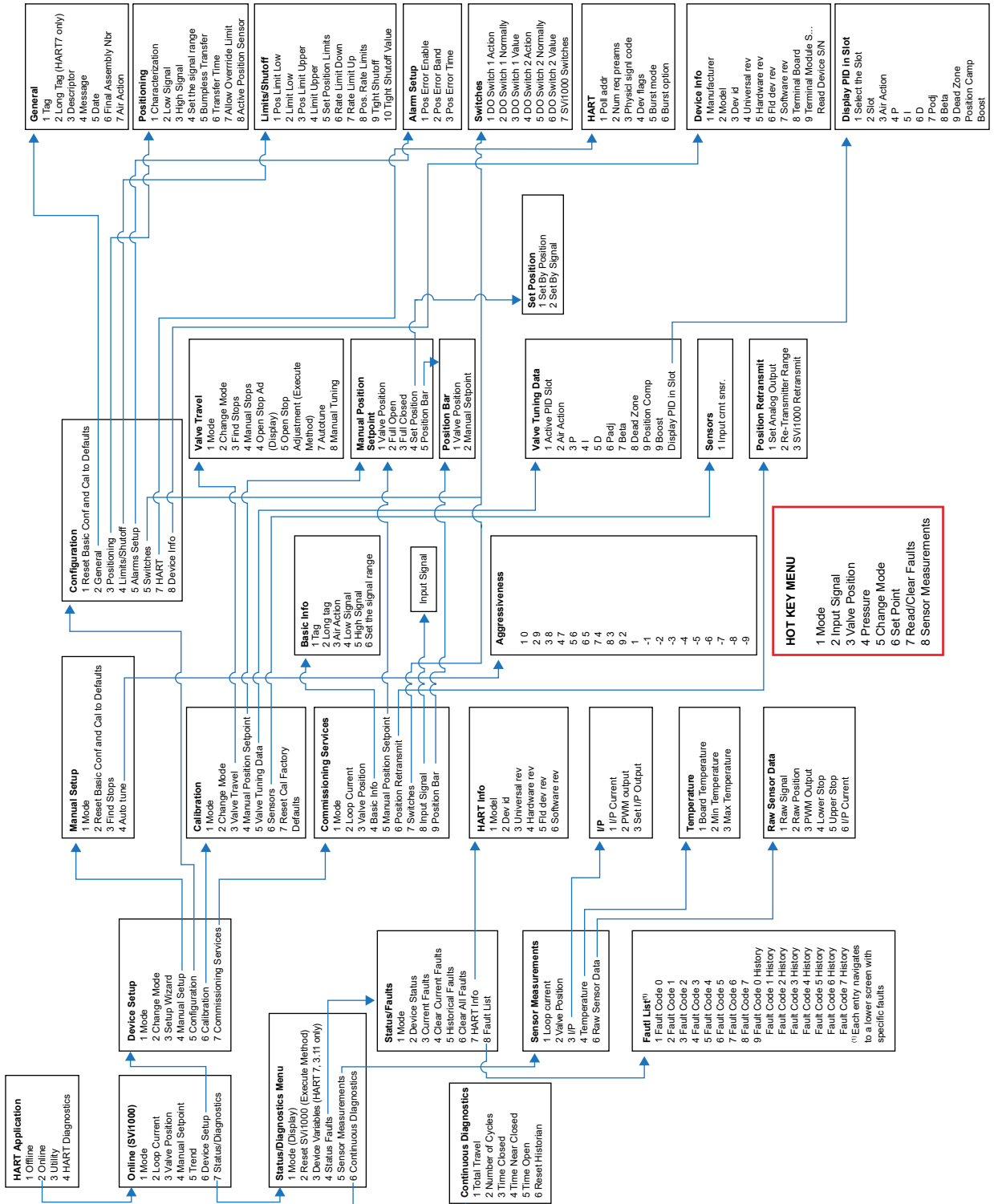

# 9. Wiring Theory for an SVi1000

## Introduction

The SVi1000 provides reliable operations of control valves with utmost simplicity in setup and commissioning. It is uniquely equipped with a non-contact travel sensor allowing for accurate positioning and maintenance free operations. The pneumatic train of the SVi1000 is a dual-stage amplification system with stainless steel parts for durability. Using HART eDDL and FDT-DTM technologies, the Masoneilan SVi1000 positioner provides interoperability with leading control systems suppliers.

## SVi1000 Setups

Typical system setups are shown in Figure 36, *General Purpose Installation* schematic.

Wiring diagrams are generalized, actual wiring must adhere to the electrical installation section of manual and local electrical codes.

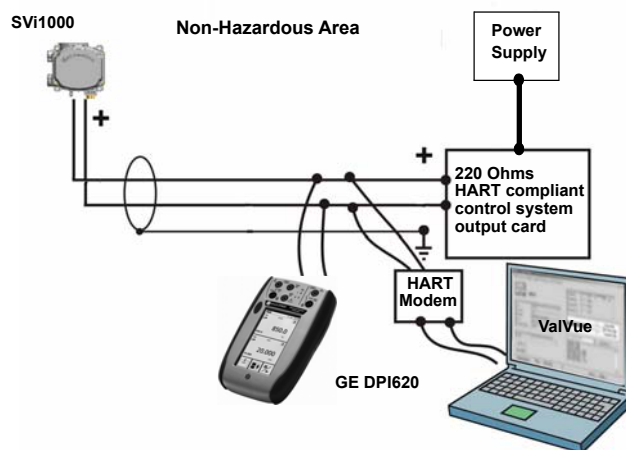

Figure 36 - General Purpose Installation

For information and diagrams to install the SVi1000 when located in a hazardous area protected by Intrinsically Safe wiring practices, refer to *ES-761 the Intrinsically Safe Wiring Requirements* section in the SVi1000 Quick Start sent with the positioner.

# Split Range Applications

The SVi1000 is designed to operate in split range configurations supporting up to three control valves connected to a single controller output. Minimum input current span for each SVi1000 is 5 mA. For each positioner the upper range value is between 8 and 20 mA and the lower range value is between 4 and 14 mA. For example, three devices might be configured with input current ranges of 4 - 9 mA; 9 - 14 mA, and 14 - 20 mA. Split range operation with SVi1000 requires special consideration of the compliance voltage. The SVi1000 requires at least 9.0 V. Two SVi1000 in series requires at least 18.0 V in addition to the voltage drops in wiring and other series devices. Typical controller output current sources rarely deliver 24 V, so the system can become voltage starved. It is possible to boost the compliance voltage of the DCS using a series wired voltage source power supply, as shown in Figure 37. The total loop voltage must not exceed the rating for the controller output current source. Contact the DCS vendor to validate this approach. See the *Position Retransmit* screen in the SVi1000 DTM to configure the software.

**Note: The internal electronic components are isolated from ground.  
Grounding the case is unnecessary for functional purposes.  
Grounding the case may be necessary to conform to local codes.**

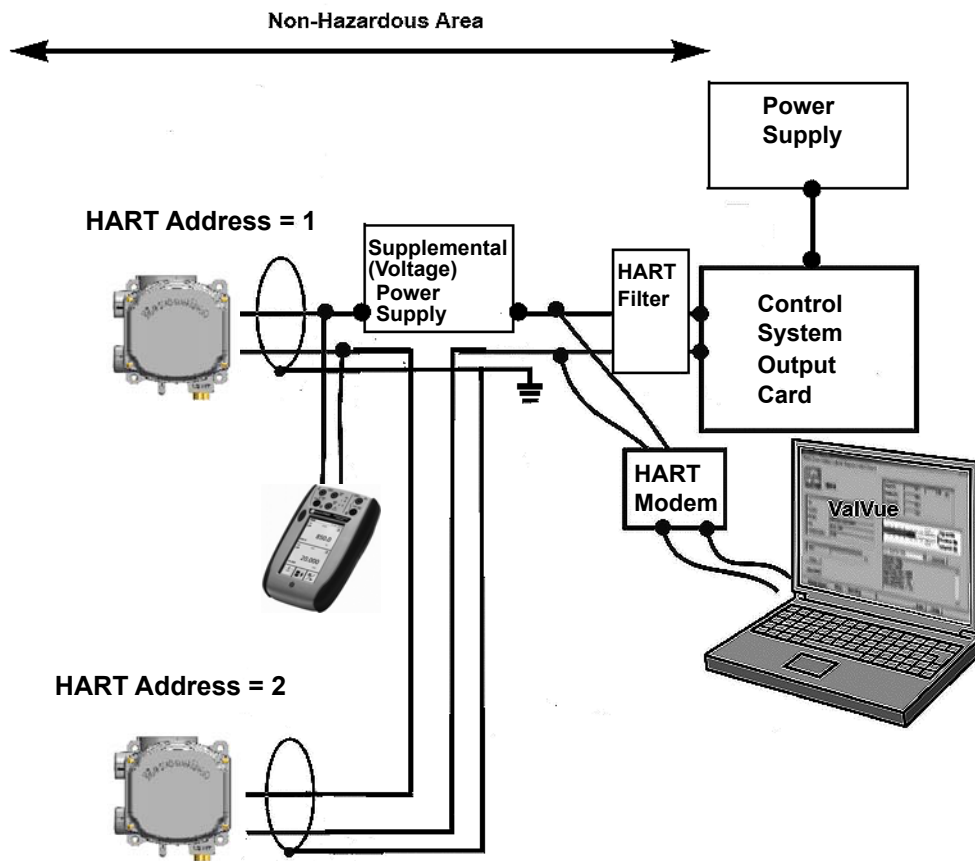

Figure 37 - Split Range with Supplemental Power Supply - Non-Hazardous



## System Connections Considerations

All system connections must comply with the HART Communications Protocol Specifications. For complete technical information refer to the Field Comm® Group, Document Number HCF-SPEC-11 and the references. The SVi1000 is a HART compliant device of type *Actuator*. It is therefore a receiver of 4 - 20 mA, and cannot have a voltage source applied to its input terminals.

### CAUTION

*Applying a voltage can cause damage and void the warranty.*

When installing the SVi1000 in a 4 - 20 mA current loop, the engineer designing the loop must consider a set of conflicting electrical requirements. The control signal to the positioner is a 4 - 20 mA current generated by the controller or DCS and transmitted to the positioner located remotely in the field. The electrical characteristics of a current loop sending a signal to the field device are different from the apparently similar loop bringing a signal to a controller from a transmitter in the field.

The positioner receives its power from the current signal. It receives its control setpoint from the value of the current and it must be able to communicate bi-directionally by superimposing signal tones upon the current signal without distorting the current signal, without the tones being affected by the electrical characteristics of the current signaling device. All these conflicting requirements must be met with equipment manufactured by various manufacturers, and work with long cables, in a noisy hostile plant environment. Energy levels are often limited for safe installation in explosive environments. Special engineering may be required to meet the signaling requirements at low energy levels.

The following will not cover all the details for a successful installation, in all cases. That is beyond the scope of this instruction. It will suffice to explain the requirements as a guide use to obtain necessary components from many sources for a successful installation.

### CAUTION

*Do not connect a HART modem and PC to a control circuit unless the controller is HART compatible or has a HART filter. Loss of control or a process upset may occur if the controller output circuit is not compatible with HART signals.*

*Install in compliance with Hazardous Area rules in accordance with local electrical codes and plant standards by trained specialists.*

*Do not connect a PC or HART modem (that is not approved as intrinsically safe) to an intrinsically safe circuit except on the safe area side of the barrier. Do not operate a PC in a hazardous area without compliance to local and plant regulations.*

**Note: A control circuit must be HART compatible or have a HART filter installed. Contact the manufacturers of the controller or DCS. See “HART Filter Requirements” on page 39.**

**Comply with current national and local regulations for electrical installation work.**

**Before carrying out any work on the device, power off the instrument or make sure that the locale conditions permit the safe opening of the cover.**

## **Wiring Guidelines**

See “Wiring Guidelines” on page 42 for a list of guidelines for a successful implementation of DC current signal, DC power, and HART communication to the SVi1000.

## **Grounding Practices**

To ensure proper grounding make sure that case, signal, and ground connections are made in compliance with the plant’s normal grounding practices. Any point in the loop can be referenced to ground, but there must never be more than one ground point. Normally ground is connected at the controller or at the intrinsic safety barrier.

The case grounding screws are located on the outside of the case. The case is isolated from all circuitry and can be grounded locally in accordance with applicable codes.

## Compliance Voltage in Single Drop Current Mode

The SVi1000 requires 9.0 Volts at 20 mA and 11.0 Volts at 4 mA. Typical smart devices require MORE voltage at higher current. The controller supplying the current has LESS voltage available at higher current. The SVi1000 is unique in that it requires LESS voltage at higher current which complements the characteristic of the source requiring only 9 Volts at 20 mA.

**Note: Improperly or inadequately grounded installations can cause noise or instability in the control loop. The internal electronics are isolated from ground. Grounding the case is unnecessary for functional purposes but grounding the case may be necessary to conform to local codes.**

Table 17 through Table 19 on page 92 provide examples of several SVi1000 installations and calculating the compliance voltage necessary to supply 9 Volts at 20 mA.

**Table 17 - Compliance Voltage for Single Channel Zener with 22 AWG Cable**

Voltage at SVi1000 at 20 mA	9.0 V
Drop in single channel Zener barrier with 342 Ohms end-to-end resistance	6.84 V
Drop in 22 AWG cable, 3000' long (30 Ohms per 1000')	1.8 V
Drop in passive HART Filter <sup>1</sup>	0.0 V
Voltage required at controller	17.64 V

<sup>1</sup> Such as MTL products.

**Conclusion:** The control system must have a compliance voltage equal to or greater than 17.64 V; contact the DCS vendor to verify compliance.

**Table 18 - Compliance Voltage for Galvanic Isolator with 22 AWG Cable**

Voltage at SVi1000 at 20 mA	9.0 V
Drop in 22 AWG cable, 3000' long (30 Ohms per 1000')	1.8 V
Required voltage at Isolator	10.8 V
Voltage available from Isolator rated to drive 22 mA into 700 Ohms <sup>1</sup>	13.2 V
Voltage required at controller	Not applicable - Isolator supplies the power

<sup>1</sup> Consult R. Stahl.

**Conclusion:** The compliance voltage issue is not present because the isolator provides all the necessary voltage.

**Table 19 - Compliance Voltage for No Barrier with HART Filter and Resistor and 18 AWG Cable**

Voltage at SVi1000 at 20 mA	9.0 V
Drop in 220 Ohm resistor	4.4 V
Drop in 18 AWG cable, 6000' long (12 Ohms per 1000')	0.6 V
Drop in passive HART Filter	2.3 V
Voltage required at controller	16.3 V

*Conclusion:* The control system must have a compliance voltage equal to or greater than 16.3 V; contact the DCS vendor to verify compliance.

## **Wire Size and Conduit**

Electrical connections are made to the electronics module terminal board. The terminals accept wire sizes up to AWG 14. The SVi1000 is supplied with one 1/2" NPT conduit entry. M20 adapters are available. Internal and external ground terminals are provided for use if grounding is required.

***Note: When an intrinsic safety barrier separates the SVi1000 from the modem or HHC a HART compliant barrier must be used.***

# HART Physical Layer Compliance of the Control System

Communications to a SVi1000 requires a HART-compliant communications loop. The HART protocol specifies the noise level, impedance requirements, and configuration of the loop. The controller or output card of the control system must comply with the Physical Layer Specification.

## Impedance Constraints

HART communication is based on the *talking* device generating an AC current superimposed on the 4 - 20 mA control signal. Two frequencies are generated; 1200 Hz representing the digital value *1* and 2200 Hz representing the digital value *0*. The *listening* device responds to the voltage generated when the AC current flows through the loop impedance. In order to generate a voltage from a current there must be impedance. HART Protocol requires that this impedance be at least 220 Ohms at the tone signaling frequencies.

HART compliant current sources are supplied with the correct Impedance Versus Frequency Characteristic. In Non-Compliant Current Sources there may be a noise reduction capacitor across the output that lowers the impedance at higher frequencies and thus lowers the signaling voltage. To be certain that at least 220 Ohms of impedance is presented by the current source a resistor can be added in series with the current source. This reduces the effective compliance voltage of the current source by 20 mA times the value of the series resistor. An added resistor is unnecessary during tests with high impedance current calibrators such as the Altek Model 334 Loop Calibrator.

## Noise Constraints

HART Communication depends on converting two frequencies (1200 and 2200 Hz) into digital values *1* and *0*. Noise can cause errors in the conversion. Conventional good wiring practice, such as use of twisted shielded pair cable with the shield and signal loop grounded at only one point, minimizes the effects of noise.

## Cabling and Interconnection Requirements

Interconnections are made using shielded twisted pair cables. The shield is connected to ground at one point only. The signal loop is grounded at only one point in accordance with plant electrical standards. It is customary to ground the signal at the controller or intrinsic safety barrier. The SVi1000 is supplied with one 1/2" NPT conduit entry. M20 adapters are available. Internal and external ground terminals are provided for case grounding requirements.



*Install the SVi1000 in accordance with local and national code in both general and hazardous area locations. Substitution of components can impair suitability for use in hazardous locations.*

**Note: The internal electronic components are isolated for ground.  
Grounding the case is unnecessary for functional purposes.  
Grounding the case may be necessary to conform to local codes.**

## Capacitance vs. Length of Cable for HART

The Field Comm® Group specifies cable capacitance requirements to preserve signal strength. Refer to the standards for detailed calculation methods.



*Do not connect a HART modem and a PC to a control circuit unless the controller is HART compatible or has a HART filter. Loss of control or a process upset can occur if the controller output circuit is not compatible with HART signals.*

## HART Filter Required for Certain Control System Output Circuits

The SVi1000 is intended for use with all control systems. However, output circuits of several major DCS systems are incompatible with the tones used for HART signals. You must verify that the DCS or controller works reliably with the HART protocol. When the DCS is incompatible an external HART filter must be installed between the field wiring and the output card. MTL manufactures HART filters, such as a 16 channel DIN rail mounted device composed of passive circuitry that introduces negligible voltage drop. For additional information, contact MTL.

**Note: A control circuit must be HART compatible or have a HART filter installed. Contact the manufacturer of the controller or DCS. See "HART Filter Requirements" on page 39 of this manual for more information.**

# 10. Optional Switch Load Limits

## Output Switches

The SVi1000 supports two identical contact outputs, SW #1 and SW #2 (Digital Output switches), that can be logically linked to status bits.

The switches are polarity sensitive and must be connected only to a DC circuit. The switch (+) terminal must be electrically positive with respect to the (-) terminal. If the (+) terminal is electrically negative with respect to the (-) terminal, then the switch will conduct, regardless of switch state.

**If the switch is connected directly across the power source, the current will be limited only by the capacity of the power source and the switch can be damaged.**

Without a load, when the switch is on (closed) the external voltage would be dropped across the switch. **This damages the switch** (Figure 38).

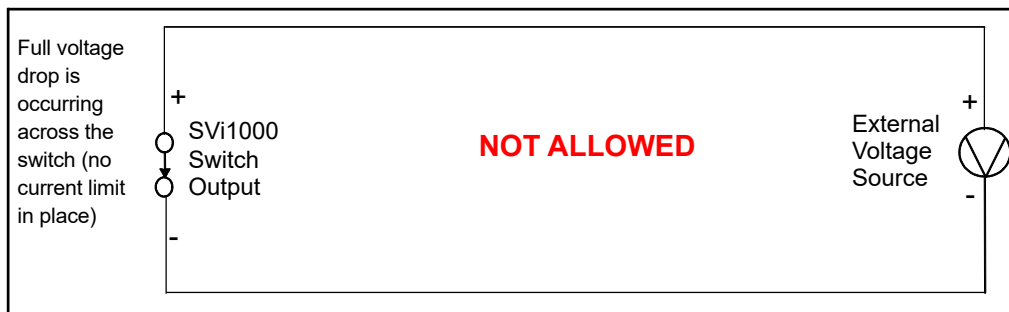

Figure 38 - Switch Installation Drawing without Load: **Configuration Not Allowed**

### General Configuration Notes

This section discusses the necessary precautions when configuring a system. See “Optional Retransmit Output” on page 98 for additional considerations for a retransmit equipped SVi1000.

	Switch OFF	Switch ON
$V_{\text{SWITCH}}$	30 VDC max.	$\leq 1$ V (Switch saturation voltage)
$I_{\text{SWITCH}}$	$\leq 0.200$ mA (Switch leakage current)	1 A max.

# CAUTION

*Incorrect polarity connection results in an effectively closed connection.*

# CAUTION

*Consult with qualified personnel to ensure that electrical requirements for the switch are met.*

The maximum voltage that can be applied to the digital switch outputs is 30 VDC. This is an open circuit parameter (the digital switch is in the open state). Under open circuit conditions, the switch current will be less than 0.200 mA.

The switch maximum current rating is 1 A. When the switch is ON, the typical switch voltage is  $\leq 1V$ .

When the switch is on (closed) the external voltage must be dropped across the load (Figure 39).

# CAUTION

*The load must be designed such that the current in the circuit is  $\leq 1 A$  at all times. Some 3rd party devices, such as incandescent lamps or solenoids, require surge and back EMF protection to prevent voltage spikes.*

## Inductive Load, Solenoid, Incandescent Lamp Configuration

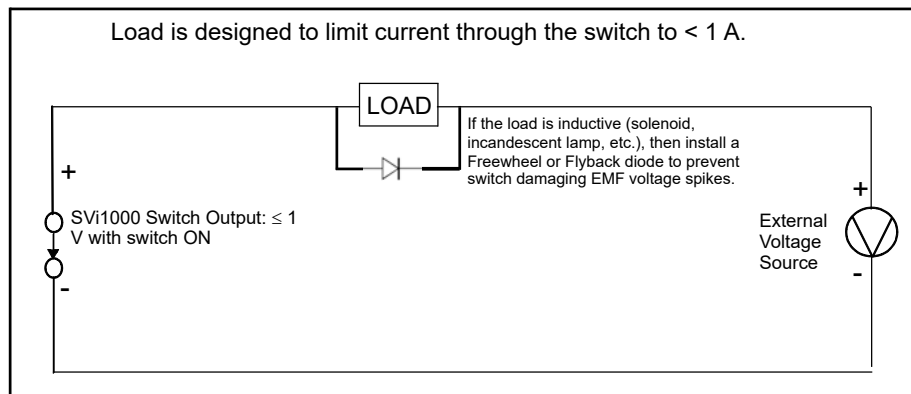

**Figure 39 - Switch Installation Drawing: Correct Configuration with Load**



## Distributed Control Systems Configurations

This section gives guidance for configuration in a DCS application. Figure 40 gives two generalized drawings that cover DCS applications to ensure switch safety.

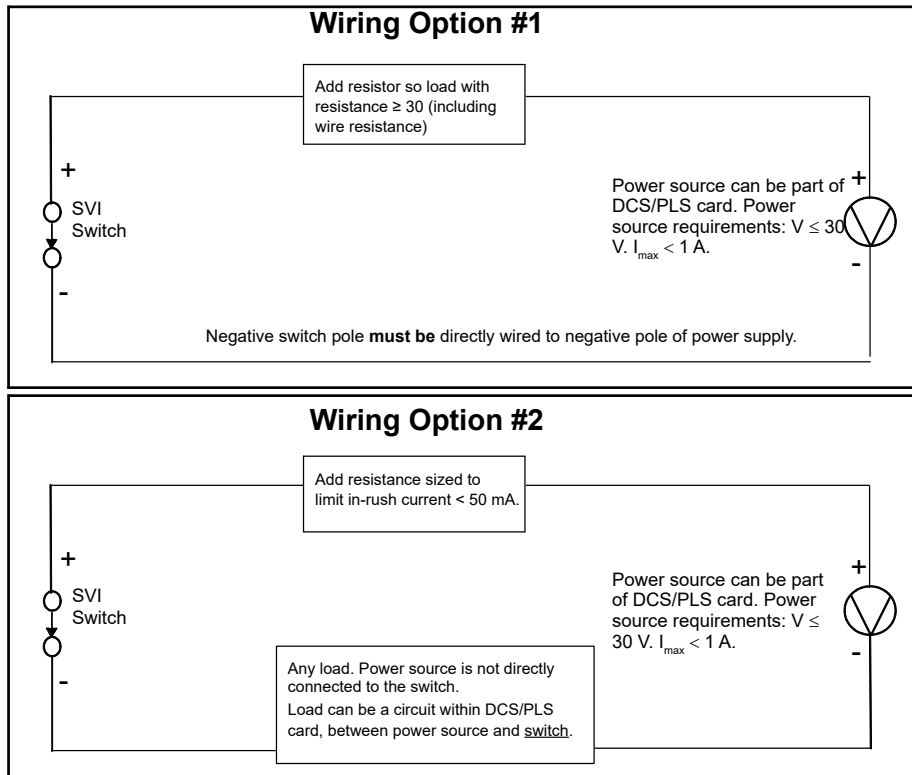

Figure 40 - DCS Switches Wiring Options

### Configuration Considerations

A typical value for 24 AWG cable about 0.025 Ohm/ft (see Wiring Option #1)).

If IS barrier is a combination of fuse, resistor and Zener diode then the connection is shown in Option #2. The barrier must have adequate resistance to limit inrush current, as the fuse cannot limit inrush current (see Wiring Option #2).

# Optional Retransmit Output

## Introduction

The SVi1000 supports a 4-20 mA Position Retransmit Feedback option. The retransmit output requires a DC power source (10 V~30 V) to properly function. The signal could be input into a DCS/PLC analog input module to read out the current valve position.

The output terminals are polarity sensitive and must be connected only to a DC circuit. The Retransmit (+) terminal must be electrically positive with respect to the (-) terminal. In normal working conditions, the retransmit output follows the valve position by outputting a 4-20 mA analog signal. If the positioner stops working due to lose of loop power or malfunctioning, the retransmit output stays at around 3.2 mA.

This section discusses the necessary precautions when configuring a system.

### CAUTION

*An incorrect polarity connection will result in device not properly functioning or with internal circuitry damage.*

### CAUTION

*Consult with qualified personnel to ensure that electrical requirements for the switch are met.*

The external series resistor is normally located in a DCS/PLC analog input module, so that the valve position (current) can be transferred into voltage (Figure 41).

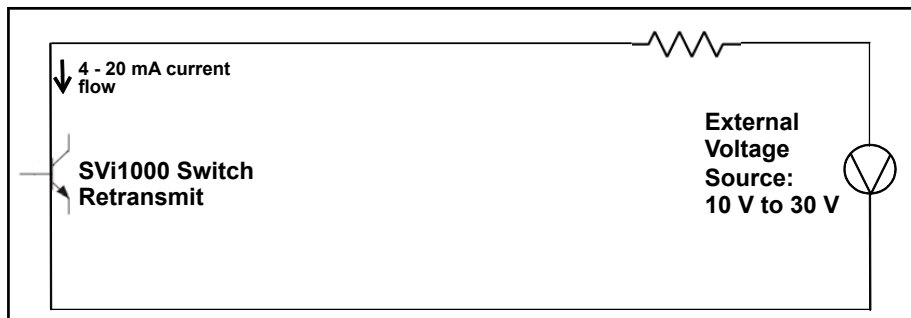

Figure 41 - Simplified Retransmit Option Installation Drawing

# 11. Air to Open and Air to Close Actuators

## Actuator Action

It is important to correctly assign air actuator action for each control variable throughout a control system. Even the control valve subsystem can be complex. Figure 42 and Figure 43 show the action of air to open, ATO, and air to close, ATC, valves when used with SVi1000. The figures show a direct acting positioner with linear and percentage characteristics. Some hysteresis is shown for the actuator pressure signal that is caused by friction in typical actuators. The scales are chosen to emphasize the relationships between input current and actuator pressure, so that the failsafe valve position is shown at the lower left of each graph.

**Note: For an ATC valve, 4 mA represents 100% valve travel not the expected 0%. The controller and other human machine interfaces must correctly show that the valve is open 100% at 4 mA and closed 0% at 20.**

The graph shows the valve movement and actuator pressure when the Tight Shut-off, T.S., option is set at about 5%. The valve movement and actuator pressure are also shown at the low current *lift-off* point at about 3.6 mA, below which the positioner is initializing its settings until power is stabilized.

Positioner input, actuator pressure and valve position relationships

Direct acting positioner with LINEAR characteristic

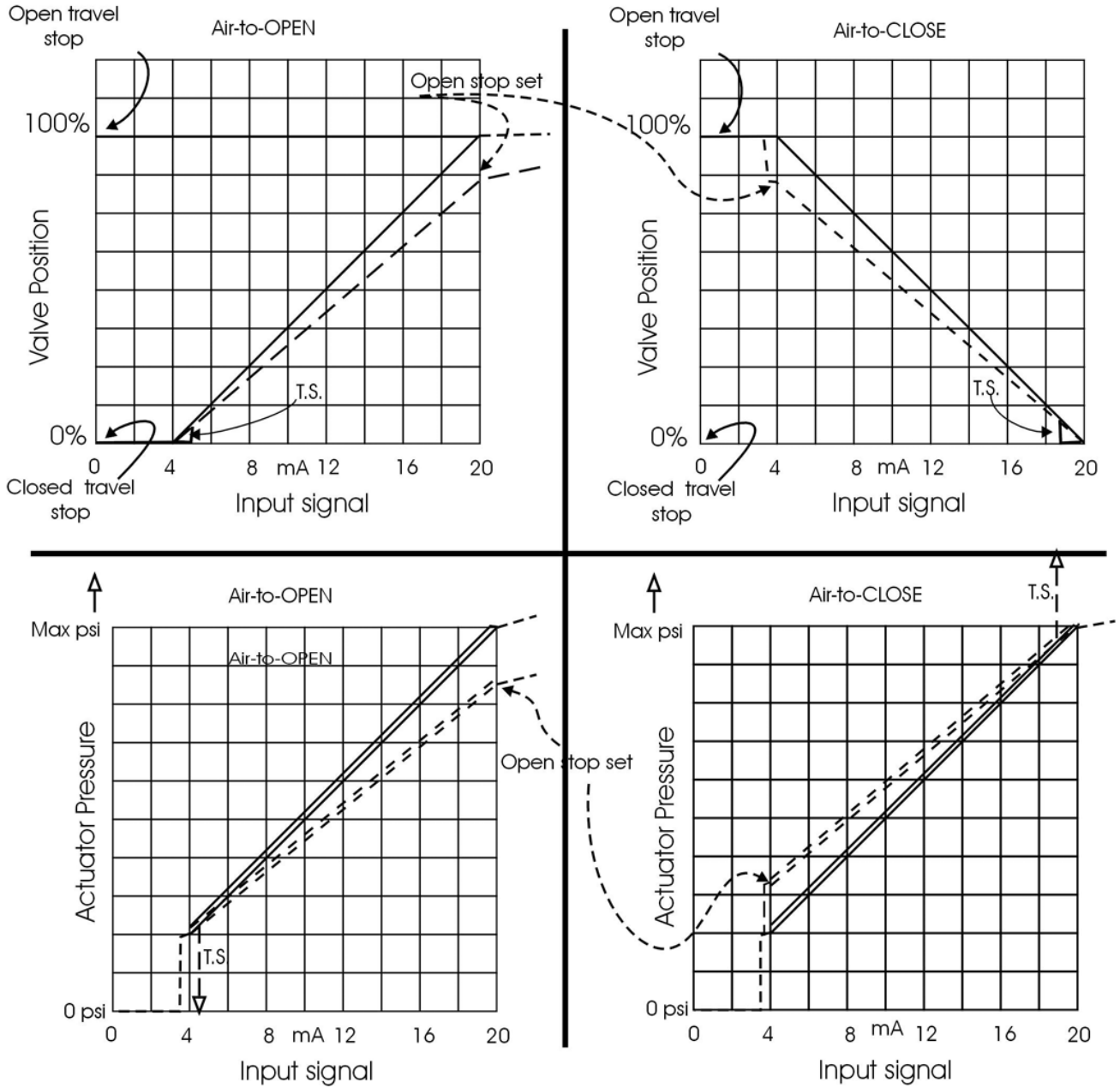

Figure 42 - ATO and ATC Action with Linear Positioner Characteristics

Positioner input, actuator pressure and valve position relationships  
 Direct acting positioner with EQUAL 50 characteristic

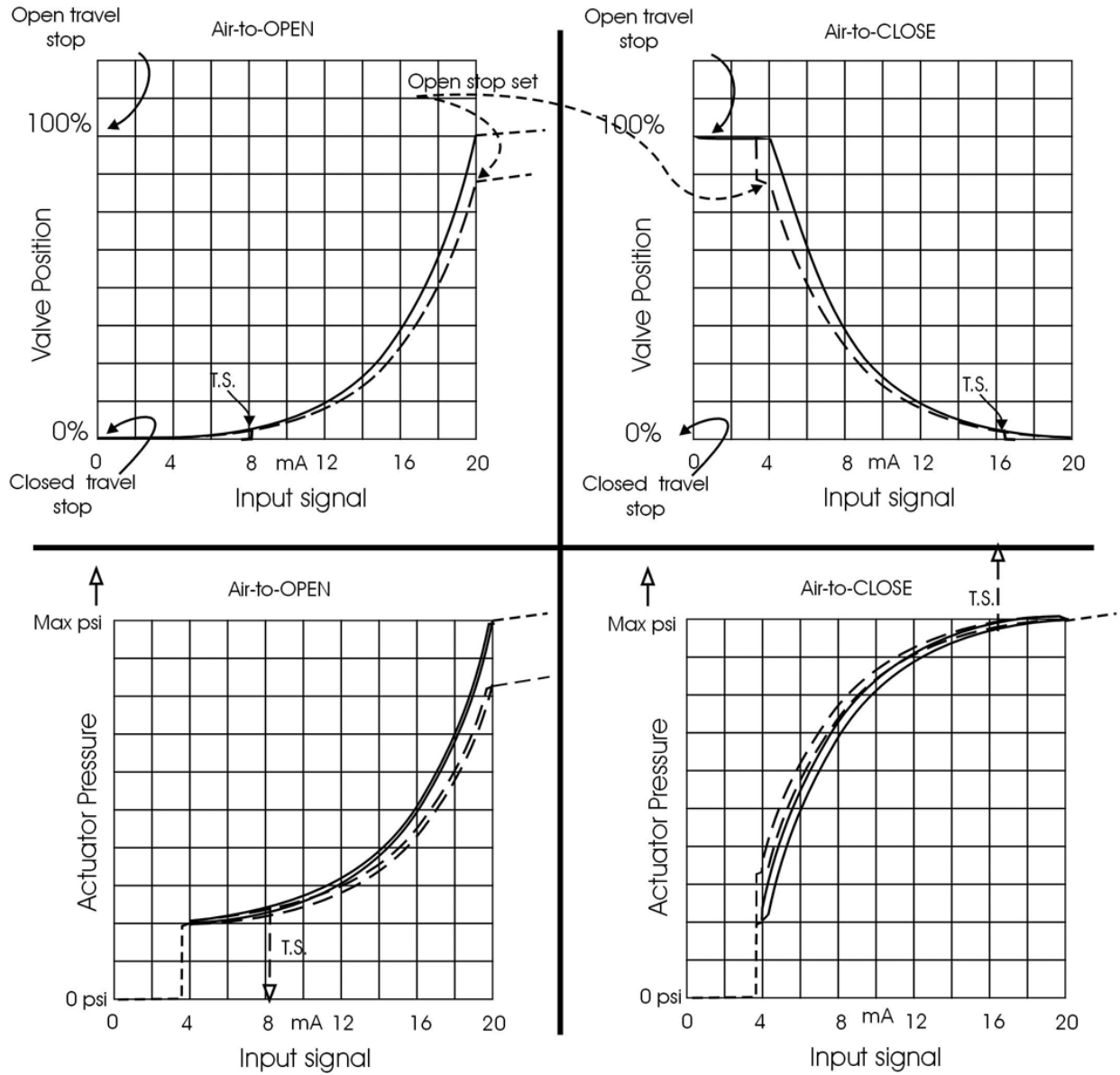

Figure 43 - ATO and ATC Action in Percentage of Positioner Characteristics

This page intentionally left blank.

# 12. SVi1000 Fault Matrix

## Fault Matrix

Table 20 describes SVi1000 faults and helps determine the cause and corrective action.

**Table 20 - Fault Matrix**

Sequence, Byte #, Bit #	FAULT Name (Anchor)	TEXT For SVi1000 Basic DTM English	HELP For SVi1000 Basic DTM English	Criticality	Fault Category	Probable Cause	Recommended Action
1, 0, 0	RESET	Reset	Device reset indicator	3	LOGONLY	Device reboot. The power recovered. Incoming signal was below 2.9 mA.	Reset the flag using the SVi100 Basic DTM or HART Host.
2, 0, 1	LOW_POWER	Low Power	Input current < 3.2 mA	3	LOWPWR	Device power is below 3.15 mA.	Increase mA only if calibration or diagnostics are to be performed.
3, 0, 2	ACTUATOR	Actuator Error	Unable to position the valve normally.	2	ANNUNCIATE	<ol style="list-style-type: none"> <li>1. Air supply is insufficient.</li> <li>2. Handwheel or mechanical stop present.</li> <li>3. Valve stuck or sticking excessively.</li> <li>4. Unbalance forces on valve trim exceeds actuator capability.</li> </ol>	<ol style="list-style-type: none"> <li>1.: Increase air supply above spring final value + 10 psig.</li> <li>2. Verify if mechanical stop is present.</li> <li>3. Perform valve signature using the SVi1000 Basic DTM.</li> <li>4. If possible, perform valve signature under process conditions. Validate sizing of actuator against process condition using ValSpeQ.</li> </ol>
4, 0, 3	AIR_SUPPLY_LOW	Low Air Supply Warning	Supply Pressure below low limit	2	ANNUNCIATE	Air supply is not turned on or is set below 10 psig.	Increase air supply above spring final value + 10 psig.

**Table 20 - Fault Matrix (Continued)**

Sequence, Byte #, Bit #	FAULT Name (Anchor)	TEXT For SVi1000 Basic DTM English	HELP For SVi1000 Basic DTM English	Criticality	Fault Category	Probable Cause	Recommended Action
5, 0, 4	POSITION_ERROR	Position Error	If T1 error is con-figured AND the position error outside the error band for time T1.	2	ANNUNCIATE	<p>1. Controller is slow to fol-low command signal due to physical valve wear, such as tight packing, stem build up, throttling surface friction or actuator friction.</p> <p>2. Valve is slow to follow command signal due to large volume actuator.</p> <p>3. Valve will not follow command signal due to insufficient or no air supply.</p> <p>4. Valve does not move because the device's mode is not set to Normal.</p> <p>5. Valve will not follow command signal due to poor controller tuning for current valve status.</p> <p>6. Valve will not follow command signal due to controller malfunction such as I/P or Relay.</p> <p>7. Valve will not follow command signal due to in line obstruction.</p>	<p>1. Perform valve signature using the SVi1000 Basic DTM.</p> <p>2. Perform step test signa-ture using the SVi1000 Basic DTM. Verify that air supply droop during filling is less than 15% or the set pressure.</p> <p>3. Validate that the air supply set to the instrument is greater than the spring final + 10 psig.</p> <p>4. Set the mode to Normal using the SVi1000 Basic DTM or HART Host.</p> <p>5. Perform Autotune or Manual tuning using the Basic DTM or HART Host.</p> <p>6. Verify if Bias Out Range or I/P Out of Range events are active.</p> <p>7. Perform valve signature using the SVi1000 Basic DTM.</p>
6, 0, 5	I2CBUS				FAILSAFE	Hardware failure: Main Board I2C bus failure.	Replace the device. Notify Baker Hughes at <a href="mailto:svisupport@bakerhughes.com">svisupport@bakerhughes.com</a> .
7, 0, 6	KEYPAD	Keypad Fault	Possible moisture inside or connector or mechanical failure.	2	LOGONLY	The local user interface is defective or pushbutton pressed for more than seven seconds (stuck).	<p>1. Check for obstruction in the device (foreign objects pushing any push button down).</p> <p>2. Replace the device.</p>
8, 0, 7	MARGINAL_POWER	Marginal Power		2	ANNUNCIATE	The input current is less than 3.85 mA.	Increase loop current to 4 mA only if calibration and diagnostics are to be performed.
9, 1, 0	CALIBRATION_FAILED	Calibration Failed	Calibration of AO or pressure failed.	3	LOGONLY	Calibration of the input sensors was outside the acceptable range when attempting to calibrate.	Using precision measuring equipment, perform calibration according to boundary limits of input sensors.



**Table 20 - Fault Matrix (Continued)**

Sequence, Byte #, Bit #	FAULT Name (Anchor)	TEXT For SVi1000 Basic DTM English	HELP For SVi1000 Basic DTM English	Criticality	Fault Category	Probable Cause	Recommended Action
10, 1, 1	FIND_STOPS_FAILED	Find Stops Failed	Find Stops process failed,	3	LOGONLY	<p>1. When calibrating stops (Zero / Span) the travel sensor moved outside the acceptable limits.</p> <p>2. A procedure timeout occurred due to an extremely large volume of actuator to displace.</p> <p>3. Valve position could not stabilize when deenergizing or when energizing the actuator.</p>	<p>1. Using the SVi1000 Basic DTM or HART Host, verify that travel sensor counts is 0 +/- 1000 with the valve closed. For a 90° valve, measured sensor count is done at 50% travel.</p> <p>2. Using the SVi1000 Basic DTM or HART Host, performs a Manual Stop calibration.</p> <p>3. Verify that air supply is adequate. Verify that accessories (boosters, quick exhausts, etc.) are not creating instability.</p>
11, 1, 2	AUTOTUNE_FAILED	Autotune Failed	Self tuning failed to converge on acceptable parameters.	3	LOGONLY	<p>1. When performing an Autotune, procedure failed to complete due valve hysteresis beyond 50%.</p> <p>2. Air supply is insufficient.</p> <p>3. Air supply droops significantly during actuator filling.</p>	<p>1. Using the SVi1000 Basic DTM or HART Host, perform an Autotune with an aggressiveness level between 2 and 4. Or manual tune the parameters according to the instruction manual.</p> <p>2. Increase air supply above spring final value + 10 psig.</p> <p>3. Perform 5 to 10% steps and observe air supply gauge on the controller.</p>
14, 1, 5	RTOS_SCHEDULING	Operating System Fault.	An internal error from which the device recovered automatically.	2	LOGONLY		Notify Baker Hughes at <a href="mailto:svisupport@bakerhughes.com">svisupport@bakerhughes.com</a> if this occurs.
17, 2, 0	BIAS_OUT_OF_RANGE	Bias Out Of Range	An important internal parameter is out of range.	1	ANNUNCIATE	The servo signal to the current to pressure converter is outside of normal throttling range.	Ensure the positioner is in Normal mode and air supply is sufficient. If it is, the I/P converter may be failing. Replace the positioner.
18, 2, 1	IP_OUT_OF_RANGE	I/P Out Of Range	I/P current feedback is out of range.	1	ANNUNCIATE	The loop current to the internal current to pressure converter is outside of normal range.	Ensure the positioner is in Normal mode and air supply is sufficient. If it is, the I/P converter may be failing. Replace the positioner.

**Table 20 - Fault Matrix (Continued)**

Sequence, Byte #, Bit #	FAULT Name (Anchor)	TEXT For SVi1000 Basic DTM English	HELP For SVi1000 Basic DTM English	Criticality	Fault Category	Probable Cause	Recommended Action
24, 2, 7	AUX_MEMO	Activation related: indicates failure of the Serial Number Hardware.			LOGONLY	Activation related: indicates failure of the Serial Number Hardware.	1. Restart the device. 2. Notify Baker Hughes at svisupport@bakerhughes.com.
25, 3, 0	NVM_-CHECKSUM0	NVM Checksum Error	The device failed to read critical data from non volatile memory.	1	FAILSAFE	A permanent corruption of the content in non volatile memory occurred.	1. Remove power to the device for 2 minutes and restart the device. 2. If the failure persist, replace the device.
26, 3, 1	RAM_-CHECKSUM	RAM Checksum Error	An internal error from which the device recovered automatically.	2	ANNUNCIATE	A corruption of the content in volatile memory occurred.	Notify Baker Hughes at svisupport@bakerhughes.com.
27, 3, 2	FW_-CHECKSUM	Flash Checksum Error	A critical internal fault.	1	FAILSAFE	Invalid firmware check-sum due to data corruption.	1. Remove power to the device for 2 minutes and restart it. 2: If the failure persists, replace device.
28, 3, 3	STACK	Stack Error	An internal error from which the device recovered automatically.	2	ANNUNCIATE	A problem with the memory stack occurred.	Clear the condition using the DTM or HART Host.
29, 3, 4	FACTORY-WRITE	Factory Write Indicator	Indicator of writes to non volatile memory allowed only for firmware upgrade.	1	FAILSAFE		N/A
30, 3, 5	NVM_TEST	NVM Test Error	An error in non volatile memory could not be repaired.	2	ANNUNCIATE	A problem occurred when testing non volatile memory.	Clear the condition using the DTM or HART Host.
32, 3, 7	FACTORY-MODE	Factory Mode Indicator	Device performs factory authorized operations.	1	LOGONLY	Device is in the factory mode.	1. Remove power to the device for two minutes and restart the device. 2. Clear the alarm using ValVue or HART Host. 3. If the failure persists, replace the complete device or electronics module.

**Table 20 - Fault Matrix (Continued)**

Sequence, Byte #, Bit #	FAULT Name (Anchor)	TEXT For SVi1000 Basic DTM English	HELP For SVi1000 Basic DTM English	Criticality	Fault Category	Probable Cause	Recommended Action
33, 4, 0	REF_VOLTAGE	Ref Voltage Fault	May indicate faulty A/D sub-system.	1	FAILSAFE	A component problem is affecting the circuit board's reference voltage.	Replace device and report the problem at svisupport@bakerhughes.com.
34, 4, 1	POSITION_SENSOR	Position Sensor Fault		1	FAILSAFE	Electronic Hall sensor component and related components failed.	Replace device and report the problem at svisupport@bakerhughes.com.
35, 4, 2	CURRENT_SENSOR	Current Sensor Fault		1	FAILSAFE	Electronic input loop current sensor is damaged.	Replace device and report the problem at svisupport@bakerhughes.com.
36, 4, 3	TEMPERATURE_SENSOR	Temperature Sensor Fault		1	FAILSAFE	Electronic temperature sensor is damaged.	Replace device and report the problem at svisupport@bakerhughes.com.
41, 5, 0	PRESSURE4	I/P Pressure Sen-sor Fault		1	FAILSAFE	1. Pressure sensor has been overpressurized and damaged. 2. Pressure sensor has failed due to some malfunction.	Replace device and report the problem at svisupport@bakerhughes.com.
42, 5, 1	PRESSURE5	Atmospheric Pressure Sensor Fault		2	ANNUNCIATE	1. Pressure sensor has been overpressurized and damaged. 2. Pressure sensor has failed due to some malfunction.	Replace device and report the problem at svisupport@bakerhughes.com.
44, 5, 3	NVM_WRITE NVM	NVM Write Fault	A write to non volatile memory failed; data may be lost on reset.	2	LOGONLY	An error occurred when attempting to write to non volatile memory.	1: Clear the condition using the DTM or HART Host. 2: If condition persists, replace device and report problem at svisupport@bakerhughes.com.
45, 5, 4	IRQ_FAULT	IRQ Fault	An internal error from which the device recovered automatically.	2	LOGONLY	The circuit board interrupt request failed.	1: Clear the condition using the DTM or HART Host. 2: If condition persists, replace device and report problem at svisupport@bakerhughes.com.
47, 5, 6	SELF_CHECK	MCU Internal Malfunction	A critical internal fault.	1	FAILSAFE	A general self check failed.	1: Clear the condition using the SVi1000 Basic DTM or HART Host. 2: If condition persists, replace device and report problem at svisupport@bakerhughes.com.

**Table 20 - Fault Matrix (Continued)**

Sequence, Byte #, Bit #	FAULT Name (Anchor)	TEXT For SVi1000 Basic DTM English	HELP For SVi1000 Basic DTM English	Criticality	Fault Category	Probable Cause	Recommended Action
48, 5, 7	SOFTWARE	Software Error	An internal error from which the device recovered automatically.	2	ANNUNCIATE	Operating system failed in conducting a task.	<ol style="list-style-type: none"> <li>1. Clear the condition using the SVi1000 Basic DTM or HART Host.</li> <li>2. If condition persists, replace device and report problem at <a href="mailto:svisupport@bakerhughes.com">svisupport@bakerhughes.com</a>.</li> </ol>
49, 6, 0	HARDWARE_MODULE_IDENT	Terminal Module ID error	Terminal Module identification error	2	LOGONLY	<ol style="list-style-type: none"> <li>1. Board ID was not written correctly during manufacturing.</li> <li>2. The Data Storage on the Terminal Module is not functioning correctly.</li> <li>3. Hardware failure.</li> </ol>	Service required, report problem at <a href="mailto:svisupport@bakerhughes.com">svisupport@bakerhughes.com</a> .
50, 6, 1	RETRAN_DATA_INTEGRITY	Terminal Mod-ule data integrity error	Retransmit Module Data Integrity Error	2	LOGONLY	<ol style="list-style-type: none"> <li>1. Data on the Retransmit Module were not written properly during manufacturing.</li> <li>2. Data on the Terminal Module are corrupted.</li> <li>3. The Data storage is not functioning correctly.</li> </ol>	Service required, report problem at <a href="mailto:svisupport@bakerhughes.com">svisupport@bakerhughes.com</a> .

# 13. Air Supply Requirements

## Air Supply Requirements

A high quality air supply greatly improves the quality of control and reduce pneumatic equipment maintenance costs. See ANSIISA-7.0.01-1996 - Quality Standard for Instrument Air. Air supply failure requires special attention to minimize process effects. Design and apply all process equipment to fail to a safe condition. This includes air supply failure. SVi1000 is designed to fail to a condition of low or no air pressure. Choose control valve actuators to move the valve to a safe condition when air pressure is low or absent. For example, a valve supplying fuel to a combustion process is normally equipped with an Air to Open valve. In other words, the fuel flow is shut off if air fails.

Additional process precautions can be taken. When the air supply recovers, the setpoint to the valve must be at a value that continues to hold the valve in its safe condition, or to move it to a known safe condition. To do so, put the control system sending the control valve position setpoint into manual mode and set to 0%. After the air supply has stabilized at its correct pressure, the setpoint can be moved to its operation point in accordance with the plant's safe start-up procedures. An additional precaution required on critical processes with an ATO control valve is to install a shut-off valve that supplements the control valve by moving to a safe condition on air failure, and remains in that condition until all necessary requirements for safe start-up have been met.



*Keep clear of moving parts. The SVi1000 can cause the valve to move when the air supply returns.*

This page intentionally left blank.

# 14. Adjusting Speed of Response

## Adjusting Speed of Response

The SVi1000 provides in its calibration software the ability to automatically tune the connected valve. The auto tune feature has robust tuning parameters designed to tolerate variations in process characteristics. You can adjust the control valve speed of response by adjusting SVi1000 parameters using ValVue tuning parameters, or using the GE DPI620. See the SVi1000 DTM help file for details.

This page intentionally left blank.



# 15. Advanced Usage

## Technology to Maximize Savings and Process Performance

This section shows examples of techniques for achieving superior process results by using ValVue with SVi1000 to simplify maintenance and to achieve the benefits of SVi1000's advanced diagnostics capabilities. It is assumed that you are using HART communications with a modem and ValVue. Refer to the ValVue SVi1000 help file for complete instructions on these and other procedures.

For ATO, the SVi 1000 may not close the valve completely, The Tight shut-off function must be employed to ensure tight shut-off.

### Tight Shutoff Application to Protect from Seat Erosion

Program the Tight Shutoff feature to prevent valve seat erosion using the full actuator force to eliminate damaging leakage. At a position setpoint of 2%, for example, this function allows full thrust to occur when the input signal is less than 2%. This solves a common cause of valve repair. Do not use tight shutoff if it is necessary to throttle the valve at very small flows.

### Tight Shutoff Application to High Pressure Liquid Letdown Valve Trim

When staged trim is used in High Pressure Liquid Letdown Valves, adjust the Tight Shutoff to move the valve from the seat to begin throttling at the minimum operable CV level. Using the tight shut-off feature in SVi1000 prevents valve seat damage that can occur when throttling at clearance flows. See recommended Tight Shutoff settings in Table 21. Adjust Tight shutoff using front panel pushbuttons, with ValVue or a HART communicator.

Table 21 - Tight Shutoff Parameters for High Pressure Liquid Letdown Trim

Masoneilan Valve Type	Valve Trim Type	Set Tight Shutoff	Positioner Characteristics
Lincoln Log	Any	15%	Linear
41000 VRT Type S	Partial Stack	6%	Linear
41000 VRT Type S	Full Stack	3.5%	Linear
41000 VRT Type C	Cage	6%	Linear
28000	Varilog	5%	Linear
Any	Class V Shutoff	2%	Linear

This page intentionally left blank.

# 16. Determining an SVI Positioner Compliance Voltage in a Control System

This discussion explains how to determine compliance voltage for an SVI positioner. It applies to the SVI II AP, SVI II ESD, SVI II APN and SVi1000.

A definition of compliance voltage is: The voltage that must be available at the control system output in order to drive the control current through the SVI II AP and all the resistive devices in series with it.

Measuring the voltage across the SVI II AP terminals doesn't give the true available system compliance voltage as the positioner self-regulates voltage as current flows through it. Additionally, it also doesn't confirm what system voltage is available under load conditions.

*Therefore, if compliance testing needs to be done, it is best done before installation.*

Use a 1K potentiometer as this is the maximum for most analog output cards and as at 20 mA this equals 20 VDC, which is a sufficient maximum.

## Compliance Test Setup

1. Configure a test setup as in Figure 44.

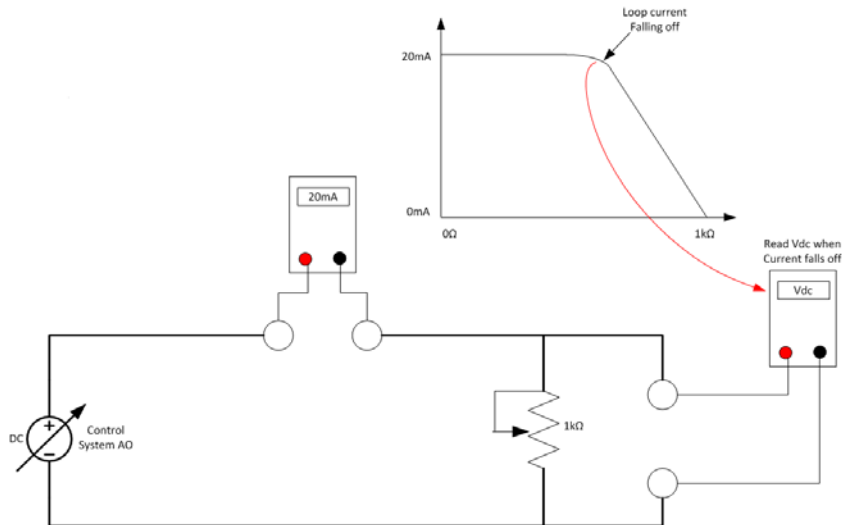

Figure 44 - Compliance Voltage Test Setup

2. Send 4 mA to the test setup.
3. Increase the potentiometer value until the loop current reaches 3.95.
4. Read the voltage across the potentiometer, which should be > 11 VDC. This is the available system voltage at the minimum output.
5. Send 20 mA to the test setup.
6. Increase the potentiometer value until the loop current reaches 19.95 mA.
7. Read the voltage across the potentiometer, which should be > 9 VDC. This is the available system voltage at the maximum output.

Table 22 lists some compliance voltage readings at positioner terminals at several currents.

**Table 22 - Expected Voltage Range at Positioner Terminals**

<b>Current</b>	<b>Compliance Voltage Requirement at Positioner Terminals</b>	<b>Expected Voltage Measured at Positioner Terminals</b>
4 mA	11 V	10 to 11 V
8 mA	10.5 V	9.5 to 10.5 V
12 mA	10 V	9 to 10 V
16 mA	9.5 V	8.5 to 9.5 V
20 mA	9 V	8 to 9 V

# 17. Glossary

Accuracy	In a control valve the position is measured between mechanical motion limits in the valve. These limits can include position variations due to actuator and valve rigidity. Therefore, accuracy is referenced to positions within normal travel of the valve independent of rigidity effects at the mechanical limits. Accuracy is the greatest deviation from the expected position within the normal travel, expressed as percent of normal travel.
Actuator Type	An actuator is a device that transforms an input signal (mainly an electrical signal) into motion. A HART compliant actuator receives a 4 - 20 mA control current signal and causes an actuation function. There are many types of HART actuators; a positioner is type of actuator. A device of type Actuator can not be connected to a circuit intended for a device of type Transmitter.
Algorithm	An algorithm is a procedure or formula for solving a problem. There are several algorithms entailed in SVi1000 operation. The SVi1000 has a position control algorithm that is a modified PID. Other algorithms embedded in SVi1000 include the STOPS method for calibrating stroke, and the autoTUNE method for establishing the best parameters for the PID algorithm.
ATC Air to Close	The combination of a single acting actuator and the control valve where the valve is closed when air pressure is applied to the actuator.
ATO Air to Open	The combination of a single acting actuator and the control valve where the valve is open when air pressure is applied to the actuator.
Characteristic	The positioner input setpoint command can be selectively modified to provide a desired relationship between setpoint and valve position. In the valve, the relationship between stroke and Cv is also called valve inherent characteristic. It is often adjusted by design, to equal percentage, for example. The positioner characteristic is applied to modify the setpoint to travel relationship of the actuator. The characteristic of the positioner must be chosen to compliment the valve. If the valve is equal percentage, set the positioner to linear. If a linear valve is installed the positioner can be set to an equal percentage characteristic to improve flow control. SVi1000 offers an eleven point custom characteristic option that can be created and edited in ValVue.
Closed	The valve position in which the flow is minimum or zero. See Tight Shutoff.

Compliance Voltage	The voltage that must be available at the control system output in order to drive the control current through the SVi1000 and all the resistive devices in series with it.
Conformity	The closeness to which the position approaches the theoretical position curve, for example equal percentage or quick opening. It is independent of effects due to valve or actuator rigidity at the mechanical limits of travel. See Accuracy.
Compliance, HART	Manufactured and tested in accordance with the Field Comm® Group standards.
Condition Monitoring	A technology for measuring the performance of process equipment and valves over a period of time to predict the need for maintenance. The technology evolved to meet NRC requirements GL 89-10, and has proven valuable to other process industries. SVi1000 and ValVue offer a suite of diagnostic tools to implement condition monitoring.
Custom	The custom characteristic in the SVi1000 has nine points to define the relationship between the setpoint and the valve position. The ValVue software allows selection of the custom characteristic that must be downloaded as pairs of data using the HART communications from a HART master. ValVue offers a graphical drag-and-drop method to define the characteristic. It includes a method to correct for geometric nonlinearity of the positioner feedback linkage.
DCS	Distributed Control System is a generic term for the common control system architecture that generally performs process control in net-worked computers and interacts with field devices through rack mounted I/O cards. A positioner is usually connected to a DCS output card which controls the 4- 20 mA current to the positioner.
Device Description, DD	The software object installed in a HART Handheld Communicator to allow it to communicate and display the custom parameters available in a field device.
EEPROM	An Electrically Erasable Programmable Read Only Memory. SVi1000 has two memories that are used for permanent storage of data that changes during operation. The micro-controller has EEPROM which permanently stores changing information such as number of actuator cycles and totalized valve travel. The program is stored in flash memory and can be upgraded.

Equal Percentage	<p>A valve characteristic designed to compensate for the loss of pressure in a pipeline as a control valve is opened. It is intended to linearize the installed flow versus lift characteristic for improved control.</p> <p>The theoretical curve is <math>y = a * e^{x \ln(1/a)}</math>, where <math>a</math> is .02, <math>1/R</math>, and <math>R=50</math> for a 50:1 equal percentage characteristic. However, the theoretical curve leaves the valve unseated by 2% at 0% input. The actual curve, shown here, is corrected to seat the valve at 0%. The corrected curve is <math>Y = (a * e^{x \ln(1/a)} - a) / (1 - a)</math>.</p>
Error Messages	The positioner stores the reasons for errors. The error messages can be read by HART or with ValVue.
Fail Safe	A mode of the positioner where the valve position is controlled to a predetermined safe position. This mode is forced by the positioner program in response to errors. If the errors are cleared then the positioner returns to the mode prior to the error.
Flash Memory	A computer memory that is not volatile. It stores all its data even when the power is off. It performs high speed reads and can be re-written many times. It is used to store programs and permanent parameters.
FSK	Frequency Shift Keying see HART protocol.
Hall Effect Sensor	A semiconductor magnetic-field sensor that measures the magnetic flux perpendicular to the sensor.
HART	HART is an acronym for Highway Addressable Remote Transducer. The HART protocol makes use of the Bell 202 Frequency Shift Keying (FSK) standard to superimpose digital signals at a low level on top of the 4-20 mA. This enables two-way communication to take place and makes it possible for additional information beyond just the normal process variable to be communicated to a smart field instrument. The HART protocol communicates without interrupting the 4-20 mA signal and allows a host application (master) to get two or more digital updates per second from a field device. As the digital FSK signal is phase continuous, there is no interference with the 4-20 mA signal.
HART Communication	<p>The Field Comm® Group is an independent, nonprofit foundation corporation specifically organized to coordinate and support the application of HART technology worldwide. Educating the industry on the capabilities and value of this important technology is a key role.</p> <p>Operating costs are offset by membership and training/support service fees. Membership is open to all suppliers, end users, and others interested in the use of HART technology.</p>

HART Filter	A filter required with certain DCS systems that are not HART compliant. It allows the 4 - 20 mA output signal to pass from control system to positioner, but blocks HART FSK tones from passing from the field wiring to the control system.
HART Master	A device, usually a PC which is controlling the communications over a HART protocol network. The HART master sends to a field device a command and requires a response.
HART Slave	A device, normally a transmitter or positioner, that communicates over a HART protocol network only in response to a command from a master.
Hazardous Area	The area of the plant where explosion hazards are present, hazards such as propane gas in a refinery, or dust in a flour mill.
Hot Swapable	The SVi1000 in combination with ValVue enables a very brief Mean Time To Repair by the following process: Upload all configuration information from installed positioner to ValVue, then replace the positioner and download the configuration file. Run STOPS, and autoTUNE, and the repair is complete.
IP Converter	The current to pressure converting device. The SVi1000 sends an analog current signal to the IP which produces a controlled pressure to the pneumatic amplifying relay.
ISA	The International Society of Automation. ISA develops and publishes international standards for use in process control. See <a href="http://www.isa.org">www.isa.org</a> .
Multidrop	A variation of the HART Communications Protocol that allows many smart field devices to draw power from and to communicate over a single pair of wires. Though most suited to multiple measurement devices, it can be used with SVi1000 to permit digital communication of setpoint as well as configuration data, to multiple positioners or a combination of positioners and measurement transmitters. Such communication may not be fast enough for flow control.
Multiplexer	Several instrument suppliers offer equipment that can be connected to multiple cables to monitor and communicate with the attached positioners and transmitters using the HART protocol. Often the multiplexer is used with a DCS that does not support HART.
NAMUR	NAMUR is a European user association of process control technology in chemical and pharmaceutical industries. "Recommendations and Worksheets are experience reports and working documents prepared by NAMUR for its members among process control users for facultative utilization". NAMUR issued a recommended accessory mounting for control valves (NE 14 Anschluß von Schwenkantrieben an Armaturen 06.08.96) which describes a method for mounting a positioner on an actuator. See at <a href="http://www.namur.de">www.namur.de</a> .



Neodymium Iron	Boron A magnet alloy which provides the highest energy magnetism available in a permanent magnet.
Non-Volatile Memory	Computer memory that is not lost when power is turned off. Used to permanently store calibration, configuration and diagnostic information in SVi1000.
NORMAL Mode	The control mode for normal use of a valve positioner. The positioner receives a setpoint from a controller or DCS and applies pressure to the actuator to move the valve to the required position.
PC	As used in this manual, a personal computer or laptop running under Windows XP or later operating system.
Position	With a reciprocating valve, the position is the distance of the plug from its seat, normally measured as a linear motion of the valve or actuator stem. With a rotary valve the position is the angle of rotation of the valve plug measured as angular rotation of the valve shaft.
Position Limit	The Actuator can be mechanically set to stop at a predetermined position by setting an adjustment, sometimes with a handwheel or screw stop. SVi1000 can be configured to provide the same limits through software control of position.
Positioner Tuning Parameters	The positioner requires six integer parameters to determine the response of the positioner to a setpoint change. Internally, the positioner uses an improved PID control algorithm to control the valve's position.
Tuning Parameters	
P	P is a dimensionless gain factor related to the proportioning action of the algorithm. It ranges from 0 to 5000. Common values for the positioner are 50 for small valves up to 4000 for large valves.
I	(0.1 sec): Integral time or reset time, is the time constant of integral control. Higher values of I cause slower integral action. Common values are 10 (1 second) to 200 (20 seconds). A value of zero disables integral action.
D	(msec): Derivative time or rate time is the time constant of derivative control expressed in milliseconds. It ranges from 0 to 200 msec. Common values are 0 to 100. A value of zero disables derivative action.
Beta	Beta is a nonlinear dimensionless gain factor, ranging from -9 to 9. When beta is 0, the controller gain is linear. Otherwise the gain is the function of error. The larger the beta, the smaller the gain for small error. Typical beta values for a valve position controller are between -9 and 0.

Padj (%) V	alves often have significantly different response when filling versus exhausting. The proportional gain is adjusted by adding Padj to P when the valve is exhausting. Padj is normally less than P.
Position Compensation Coefficient	The response of the valve is different when the valve is nearly closed than when the valve is nearly open. The position compensation coefficient, which is a number between 0 and 9, allow the control algorithm to optimize the valve response.
Damping Coefficient (Boost)	The valve response can be made slower for some applications. A value of 0 gives no damping, and a value of 9 gives maximum damping of valve motion.
Dead Zone(%)	When the valve position is within the setpoint +/- the dead zone, no additional position control is performed. This value is normally 0%, however for high friction valves (e.g. valves with graphite packing) a higher dead zone helps avoid limit cycling due to the stick/slip action of the valve. In these cases the dead zone chosen might be 0.2% to 1%.
Quick Opening	(see Characteristic)
Relay, Pneumatic	The component that amplifies the pneumatic control signals to provide a wide range of actuation pressure and to supply and vent at high flow rates for responsive control.
Safe Area	The area of a plant where there never is an explosion hazard present, such as the control room or a wire marshalling rack area.
Sig Hi	In the SVi1000 configuration, the input current setting at which the valve is fully open (ATO) or fully closed (ATC).
Sig Lo	In the SVi1000 configuration, the input current setting at which the valve is fully closed (ATO) or fully open (ATC).
Single Acting	The action of a position with a single pneumatic output for operation with a spring return actuator.
Split Range	A control configuration where a single control output is sent to two or more control valves. Each control valve positioner is calibrated to respond to a separate portion of the control signal. An example is a steam valve and a cooling water valve arranged to be both closed at 50% and the steam valve to open.
STOPS	The SVi1000 runs STOPS procedure to adjust the positioner to actual valve travel. First the output pressure is reduced to zero and the position is recorded. That position corresponds to 0%. The output pressure is raised to its maximum based on supply pressure. The position is recorded and corresponds to 100%.
Stroke	The total range of valve travel (An accumulated value of 100% travel = 1 stroke. The travel does not need to occur in one movement.) Often used as a verb to describe the process of moving the valve.

Tag	The formal designator the control valve used in control loop documentation.
Tight Shutoff (TS)	A positioner property which is selected and adjusted when it is desired to prevent operation of the valve at or near the closed position. The positioner causes all available actuator force to be applied to the valve seat at a position set point equal to or less than the TS adjustable parameter. A dead band is applied to prevent cycling in and out of this behavior.
VDE/VDI 3845 valve actuators.	A Standard common in Europe for mounting positioners and accessories on rotary

This page intentionally left blank.

# 18. SVI Physical Characteristic Identification

This guide is designed to help the user to quickly identify the different SVI product versions: SVI3, SVI II AP, SVi1000, SVI II-1, SVI II or SVI 1.

## Body Styles

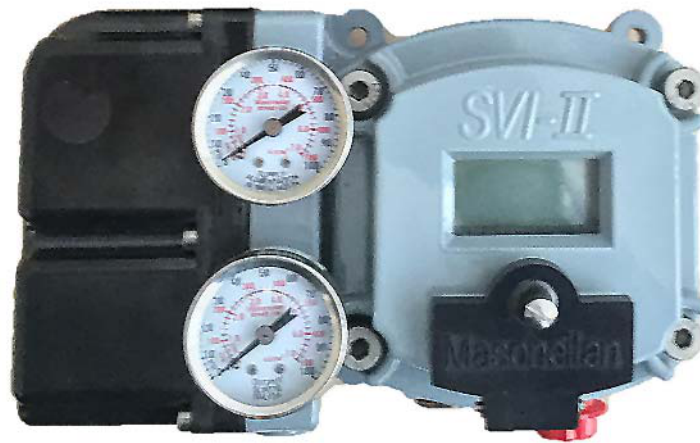

Figure 45 - SVI3 : Released July 2021



**Recognizable Feature: SVI shown on Display Cover (Only change is SVI lettering on cover)**

Figure 46 - SVI II AP: Cover Phase In Started 2015



Recognizable Feature: SVI-II (with dash) shown on Display Cover  
Figure 47 - SVI II AP: Cover Phase Out Started 2015



Figure 48 - SVI1000: Started Shipping 2011

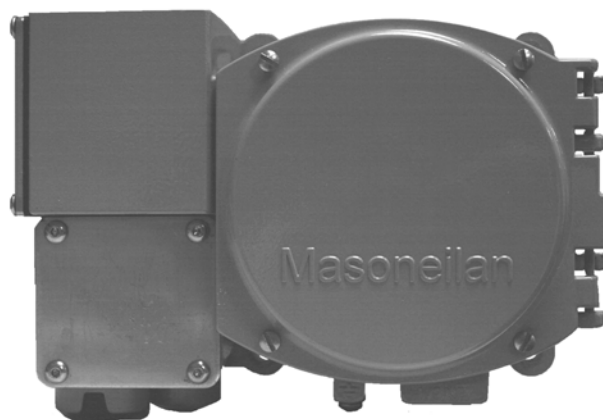

Figure 49 - SVI II-1: Obsolete



**Recognizable Feature: SVI II shown on Display Cover**

**Figure 50 - SVI II: Obsolete**



**Recognizable Feature: Round body/LCD face**

**Figure 51 - SVI I: Obsolete**

# Additional Differences Between SVI II AP and SVI II

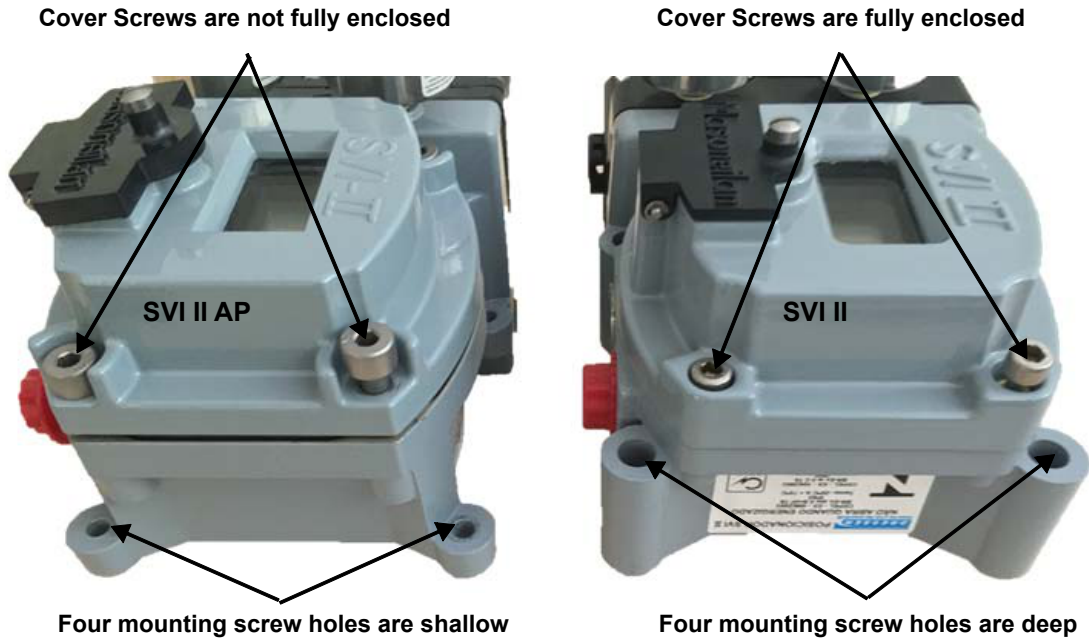

Figure 52 - Cover and Mounting Screw Configuration

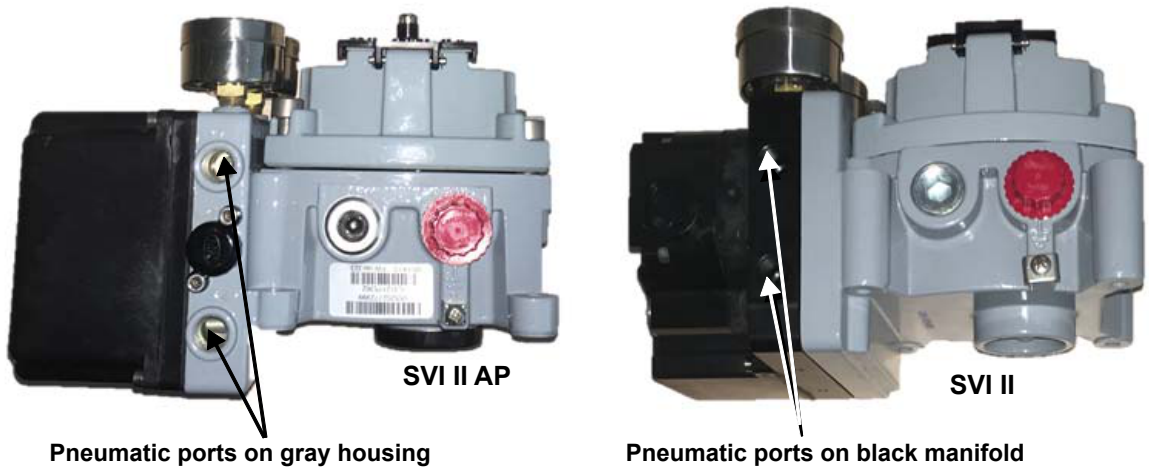

Figure 53 - Pneumatic Ports





**SVI II AP Blind Cover (New)**



**SVI II AP Blind Cover (Original)**

**Figure 54 - SVI II AP Cover Differences**

# SVi1000 Label Identification

Figure 54 shows the label without diagnostics (firmware 1.x) and Figure 55 shows the label with diagnostics. Units with diagnostics start with firmware revision 2.x. Note the differences in the label layout.



Figure 55 - SVi1000 Diagnostics Labels: No Diagnostics vs. Diagnostics



Figure 56 - SVi1000 Diagnostics Labels: With Diagnostics

# 19. How Do I?

The lists below give you an idea of what tasks you need to accomplish using the SVi1000 DTM. The tasks are split into *Getting Started Tasks* that are necessary at least the first time you configure and *Common Tasks* for tasks performed at anytime. Tasks are listed by the topic name in the SVi1000 online help or help pdf version (), downloadable at <https://valves.bakerhughes.com/resource-center>.

## Getting Started Tasks

- *ValVue Licensing* leads you through the entire registration process.
- *Full Wizard* explains how to use the wizard to do the initial setup.
- *SVi1000 HART Screen Overview* explains the operations of the screen where you view process information, change mode and change the setpoint.
- *Calibration Autotune Screen*: to run auto-tune.

## Common Tasks

- *Configuration General Screen*: to configure *Tag Information, Descriptor, Date*, etc. You can read parameters from the positioner in Setup, Manual and Normal modes and write in Setup mode.
- *Configuration Position Screen*: to set all position based limits.
- *Configuration I/O Configuration Screen*: to configure switch states, activate/deactivate digital input, configure the input signal range.
- *Configuration Options Screen*: to configure the parameters related to valve characterization and bumpless transfer.
- *Calibration Screen*: to restore the factory calibration data for all sensors.
- *Calibration Range Screen*: to automatically search for the mechanical valve travel limits.
- *Calibration Autotune Screen*: to commission a valve positioner. It includes the ability to configure PID parameters and aggressiveness while tuning.
- *Calibration Manual Tune Screen*: to enter manual tuning parameters.

- *Configuration HART Screen*: to configure and work with Burst mode.
- *Commissioning Services Configuration Screen*: to change Tag and to configure the input signal high/low.
- *Commissioning Services Position Retransmit Screen*: to configure the settings when the SVi1000 is configured to send a retransmit signal
- *Diagnostics Screen*: to perform a device reboot of the SVi1000 while in Manual, Normal and Failsafe mode.
- *Diagnostics Check Raw Data Screen*: to view the raw counts of status of signals, temperatures and I/Os. Additionally, you can monitor and Set I/P and Unset I/P.
- *Diagnostics Signature Measurement: General Discussion*: to begin using the diagnostic tests.
- *Commissioning Services Screen*: to monitor signal, position and setpoint
- *Commissioning Services Manual Position Setpoint Screen*: to fully open the valve, fully close the valve or use the Manual Setpoint feature to input a setpoint in percentage of valve position or in signal range (mA).
- *Commissioning Services Switches Screen*: to set the default operating position for the switches.
- *Continuous Data Screen*: to view data about valve operations at closing and opening, which useful in valve operation analysis
- *Diagnostics Status Screen*: to see the SVi1000 operating and internal status. You can reset the Current Faults or All Faults (Current and Historical).
- *Device Info Screen*: to view device Info data.

This page intentionally left blank.

This page intentionally left blank.

This page intentionally left blank.

# Direct Sales Office Locations

**Australia**

Brisbane  
Phone: +61-7-3001-4319

Perth  
Phone: +61-8-6595-7018

Melbourne  
Phone: +61-3-8807-6002

**Brazil**

Phone: +55-19-2104-6900

**China**

Phone: +86-10-8400-7888

**France**

Courbevoie  
Phone: +33-1-4904-9000

**India**

Mumbai  
Phone: +91-22-8354790

New Delhi

Phone: +91-11-2-6164175

**Italy**

Phone: +39-081-7892-111

**Japan**

Tokyo  
Phone: +81-03-6871-9008

**Korea**

Phone: +82-31-620-1736

**Malaysia**

Phone: +60-3-2161-03228

**Mexico**

Phone: +52-55-3640-5060

**Russia**

Veliky Novgorod  
Phone: +7-8162-55-7898

Moscow

Phone: +7-495-585-1276

**Saudi Arabia**

Phone: +966-3-341-0278

**Singapore**

Phone: +65-6861-6100

**South Africa**

Phone: +27-83-387-9300

**South & Central  
America and the Caribbean**

Phone: +55-12-2134-1201

**Spain**

Phone: +34-936-093-141

**United Arab Emirates**

Phone: +971-4-8991-777

**United Kingdom**

Phone: +44-7919-382-156

**United States**

Houston, Texas  
Phone: +1-713-966-3600

Find the nearest local Channel Partner in your area:

[valves.bakerhughes.com/contact-us](https://valves.bakerhughes.com/contact-us)

## Tech Field Support & Warranty:

Phone: +1-866-827-5378

[valvesupport@bakerhughes.com](mailto:valvesupport@bakerhughes.com)

[valves.bakerhughes.com](https://valves.bakerhughes.com)

Copyright 2022 Baker Hughes Company. All rights reserved. Baker Hughes provides this information on an "as is" basis for general information purposes. Baker Hughes does not make any representation as to the accuracy or completeness of the information and makes no warranties of any kind, specific, implied or oral, to the fullest extent permissible by law, including those of merchantability and fitness for a particular purpose or use. Baker Hughes hereby disclaims any and all liability for any direct, indirect, consequential or special damages, claims for lost profits, or third party claims arising from the use of the information, whether a claim is asserted in contract, tort, or otherwise. Baker Hughes reserves the right to make changes in specifications and features shown herein, or discontinue the product described at any time without notice or obligation. Contact your Baker Hughes representative for the most current information. The Baker Hughes logo, Masoneilan, SVI, ValVue and Camflex are trademarks of Baker Hughes Company. Other company names and product names used in this document are the registered trademarks or trademarks of their respective owners.

**Baker Hughes** 