

OPERATING AND MAINTENANCE MANUAL

Series 2200/2220 – 1.0” & 2.0”



Series 2200



Series 2220

TABLE OF CONTENTS

INTRODUCTION	1
About the Series 2200/ 2220 Valve	1
Identifying the valves	1
1.0 VALVE INSTALLATION AND START-UP	2
2.0 VALVE MAINTENANCE	3
2.1 Actuator Disassembly	3
2.2 Actuator Re-Assembly	4
2.3 Valve Disassembly	4
2.4 Trim Inspection	5
2.5 Trim Restoration	6
2.6 Valve Re-Assembly	6
3.0 REPAIR KITS	6
4.0 TROUBLE DIAGNOSIS	7
4.1 Internal Leakage Problems	7
4.2 External Leakage Problems	8
4.3 Valve Performance Problems	9
5.0 VALVE BODY STYLES AND PORT ORIENTATION MARKINGS	11
TABLES	
Table 1 — Maintenance Schedule	2
Table 2 — Lapping Compounds	5
Table 3 — Bridge Symbol and Valve Body Port Orientation	1

INTRODUCTION

CAUTION!

You will see warning boxes like this throughout the manual. Please read and strictly observe these warnings to prevent personal injury or equipment damage. Before you begin the installation, operation or repair of equipment, make sure to completely review and understand the instructions in this manual.

The information contained in this manual is about the 1.0” and 2.0” Norriseal Series 2200 and 2220 Control Valves. Please refer to separate manuals for all other controllers, positioners and their optional accessories.

About the Series 2200/ 2220 Valve

The Series 2200/ 2220 Valve is designed for general use for either liquid or gas source that require a throttle or on/off control. The Series 2200/2220 Valve has one port with three different types of plugs (or “un-

balanced trim”): quick opening, equal percent and modified percent. The pneumatic spring-diaphragm actuator is either open yoke (model 2200) or close-coupled (model 2220). The valve has a hammer nut closure.

All Norriseal valves come with spring-diaphragm pneumatic actuators that are either reverse-acting (fail-closed) or direct-acting (fail-open). Both are available in No. 9 (35 sq. in.) and No. 12 (70 sq. in.).

The Series 2200/ 2220 valves have non-adjustable, spring-loaded packing with PTFE V-rings and a spring below the packing to maintain a tight stem seal.

WARNING!

Before attempting to disassemble or repair this valve, please make sure that all pressure going through the valve has been relieved. Failure to do this will cause personal injury and/ or damage

to the device. In addition, the fluid that projects from the device after failure to comply with these warnings will cause injury to people, equipment and the environment.

Identifying the valves

The nameplate of each valve has the assembly information you need to replace the part and can be found on its upper diaphragm. It is important to use genuine Norriseal parts when repairing valves. When calling your Norriseal representative, make sure to have the serial and model numbers found on the nameplate.

WARNING!

When consulting the nameplate please pay attention and adhere to the maximum pressures and temperatures for the valve. Should you need to increase the limitations of the parts, install relief valves or other over-pressure protection devices in the pressure lines.

CAUTION!

Your valve configuration and construction materials were selected to meet specific pressure, temperature, pressure drop and fluid conditions. Some combinations of body and trim are limited in their pressure drop and temperature ranges. Please call the Norriseal sales office or your sales representative before subjecting the valve to conditions outside the specified range.

1.0 Valve Installation and Start-Up

1. Inspect the valve for any damage or residue that might have occurred during packing or shipping. Remove all protection material from the parts.
2. **Make sure to blow air into all the pipelines to rid them of any foreign material. Threaded and gasketed surfaces should also be free from residue.**
3. Be sure to install the valve so that flow direction is under the seat for throttling trim. For quick opening trim, it can be installed either under the seat or over the seat. (reference Table 3)
4. Good piping practice during installation includes using a suitable gasket in between the body and pipeline flanges. For threaded (NPT) bodies use pipe thread sealant.
5. This is a good time to inspect the nameplate on your valve. Identify the working pressure limitations of your valve (they are rated ANSI 150, 300, 600, 900, 1500, or 2500 class) and DO NOT exceed the marked pressure.
6. If you choose to insulate your valve, DO NOT insulate it above the hammer nut.

7. Connect the supply pressure to the actuator or the positioner connection. (REMINDER: refer to the nameplate for pressure limitations) Run the actuator through a couple of cycles to confirm the proper operation of the valve.

WARNING!

Do not supply pressure that exceeds the maximum on the nameplate. Under no circumstances should the actuator supply pressure exceeding 35 psig for #12 actuators or 50 psig for #9 actuators.

8. In certain operating conditions the actuator's springs may need to be adjusted. To adjust the springs:
 - A. **FOR A REVERSE ACTUATOR**
Loosen the lock nut on the adjusting screw located on the top of the actuator spring housing. To achieve a tighter shut off, increase the spring's preload and plug seating force by turning the adjusting screw CLOCKWISE. To reduce the preload, turn the

adjusting screw COUNTER-CLOCKWISE. Be sure to tighten the lock nut after making the needed adjustments.

NOTE: Don't adjust the spring past the point necessary to achieve shut off and past the maximum actuator pressure allowable to fully open the valve.

- B. **FOR A DIRECT ACTUATOR**
Remove the spring cover by first loosening the two set screws at the base of the cover. To increase the spring's pre-load, turn the adjusting nut CLOCKWISE. To reduce the pre-load, turn the adjusting nut COUNTERCLOCKWISE. Be sure to replace the spring cover and tighten the set screws after adjusting your springs.

NOTE: Only adjust the spring tension to the extent necessary to fully open the valve at operating conditions. Any additional adjustments will result in a reduction of plug seating force, possibly resulting in trim leakage.

TABLE 1 MAINTENANCE SCHEDULE *

ITEM	INSPECTION SCHEDULE
Valve Trim (Seat, Plug)	Inspect every 6 months, under normal service conditions (low-pressure drop and no sand or abrasives in fluid).
	Or inspect every 2 months, under service conditions, such as high-pressure drop, corrosion, or fluid with sand.
Stem Packing	Inspect Packing at least once a year.
Actuator	Inspect Diaphragm, Spring and Stem once a year.
Body	The body should last many years under normal conditions. However, under severe conditions of corrosion or erosion from sand in the flowing fluid, high-pressure drops, or high-fluid velocity, body life may be greatly reduced. Inspect the body each time the bonnet is removed.
Bonnet	Inspect Bonnet once a year or whenever trim inspection is performed.
Seals	Inspect O-rings each time valve is disassembled.

*Under certain operating conditions, this suggested maintenance schedule will not be adequate and shorter time intervals may be required.

2.0 Valve Maintenance

WARNING!

Before making any repairs to your valve follow the following four steps:

1. Isolate the valve from the process/ system.
2. Shut off all supply lines to the actuator.
3. Release the process pressure (both upstream and downstream).
4. Vent the actuator supply pressure.

Be aware that all valve parts are subject to normal wear and tear, and as a result, should be inspected and replaced regularly, as necessary. The frequency of your inspections will depend on the frequency and type of usage your parts are put through. During each inspection, you will be required to disassemble and re-assemble the valve. The following section will describe this process in detail. Should maintenance be necessary, it can be done while the valve body is in line as long as:

- 1) The line is not in service
- 2) The line is isolated from active process by block valves.

Refer to the parts diagrams during disassembly and re-assembly. There you will find a complete list of parts and configurations.

2.1 Actuator Disassembly

A. Direct (Fail-Open) Actuators

1. Vent and disconnect the supply pressure from the actuator.
2. Remove the spring cover by first loosening the set screws at the base of the cover.
Turn the adjusting nut COUNTER

3. CLOCKWISE until the spring's preload is completely removed (or de-energized). Remove the adjusting nut, washer, upper spring retainer and spring.
4. Remove the nuts and screws from around the diaphragm housing flange and remove the upper diaphragm housing by sliding it carefully upward and off the stem.
5. Remove the cotter pin and unscrew the upper stem from the lower stem.
6. Remove the bearing washers, O-ring, diaphragm, diaphragm plate and hex nut (2220).
7. Unscrew the lower housing from the yoke (2200) or bonnet (2220). This is the final step in disassembly of the 2220 valve actuator.
8. Loosen the two jam nuts securing the valve stem to the actuator stem and unscrew the stems. Remove the travel indicator from the valve stem (2200 only).
9. If repair warrants, unscrew the yoke (2200) from the bonnet.

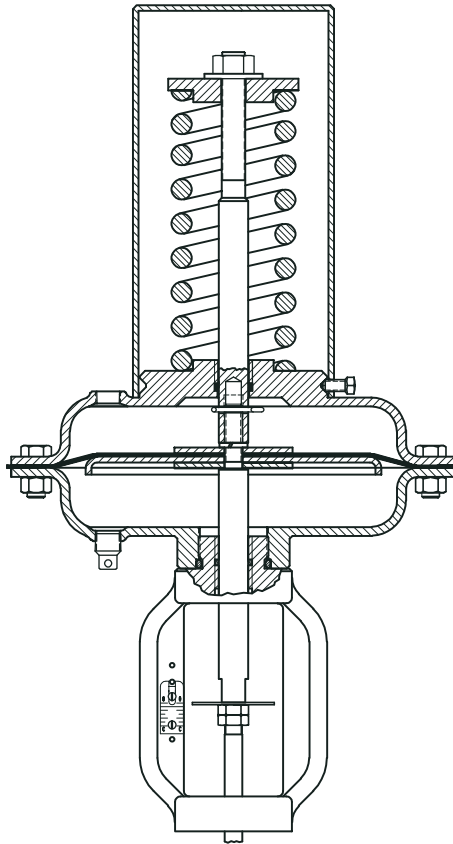

Series 2200 Yoke-Mounted
Direct-Acting

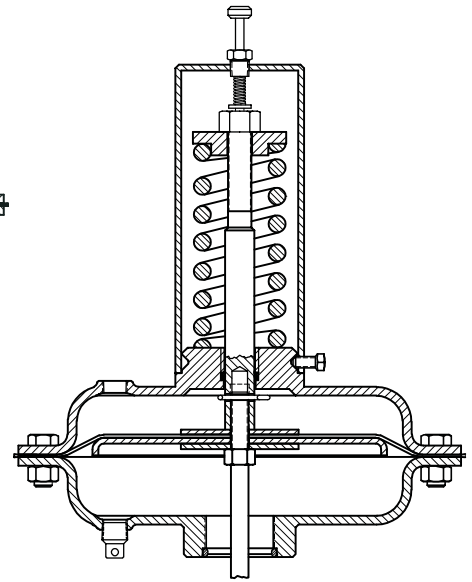

Series 2220 Close-Coupled
Direct-Acting

A. Reverse (Fail-Closed) Actuators

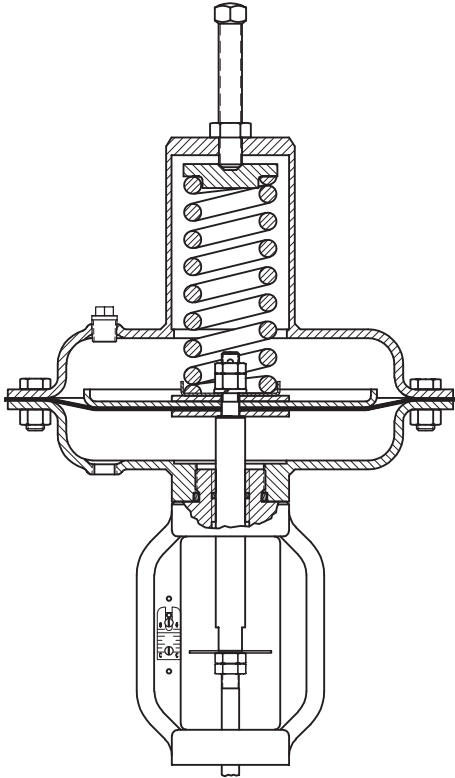

Series 2200 Yoke-Mounted
Reverse-Acting

5. Remove the lock washer, spring retainer, bearing washers, O-ring, diaphragm, diaphragm plate (and hex nut – 2220).
6. Unscrew the lower housing from the yoke (2200) or bonnet (2220). This is the final step in disassembly of 2220 valve actuator.

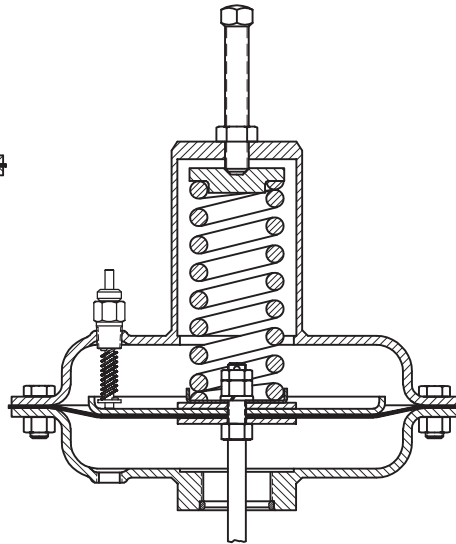

Series 2200 Close-Coupled
Reverse-Acting

1. Vent and disconnect supply pressure from the actuator.
2. Loosen the lock nut on the adjusting screw on top of the actuator spring housing. Turn the adjusting screw COUNTERCLOCKWISE until the spring's preload is completely removed (or de-energized)
3. Remove the nuts and screws from around the diaphragm housing flange and remove the upper diaphragm housing, spring and upper retainer.
4. Remove the nuts from the top of the stem.
7. Loosen the two jam nuts securing the valve stem to the actuator stem and unscrew the stems (2200 only). Remove the travel indicator from the valve stem.
8. If repair warrants, unscrew and remove the yoke (2220) from the bonnet

2.2 Actuator Re-Assembly

To re-assemble the actuator, lubricate the O-rings and simply reverse the steps of the disassembly procedure in Section 2.1 for the appropriate actuator (direct or reverse).

2.3 Valve Disassembly

A. With the Actuator Remaining Attached to the Valve Body

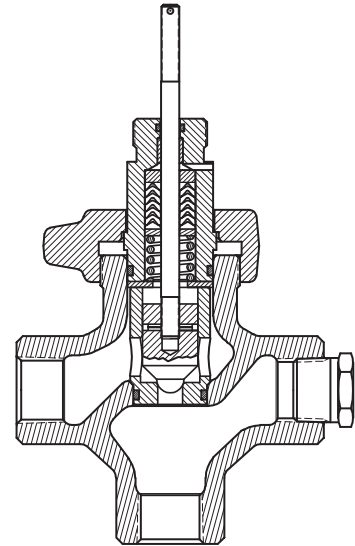

Series 2200/2220 Body

CAUTION!

Use care to avoid damaging O-ring sealing surfaces. Assume all of these parts are in good condition when disassembling the valve and protect them accordingly. The surface finish of the valve stem is critical for creating a reliable packing seal. The bore of the seat/ cage is critical for smooth operation of the valve plug. The seating surfaces of the valve plug and seat/ cage are critical for tight shutoff.

WARNING!

Before making any repairs to your valve follow the following four steps:

1. Isolate the valve from the process/ system.
2. Shut off all supply lines to the actuator.
3. Release the process pressure (both upstream and downstream).
4. Vent the actuator supply pressure.

1. Vent and disconnect supply pressure from the actuator.

2. **Remove all spring compression.**

a. **For A Direct Actuator: Loosen the two set screws, remove the spring cover and turn the adjusting nut COUNTER CLOCKWISE until all spring compression is removed from the actuator spring.**

b. **For A Reverse Actuator: Loosen the lock nut on the actuator adjusting screw and turn the adjusting screw COUNTERCLOCKWISE until all spring compression is removed from the actuator spring.**

3. Unscrew the hammer nut (turning COUNTERCLOCKWISE) from the valve body by striking the lugs with a hammer.

4. Lift all top workings (bonnet, actuator, stem and plug) from the valve body and place on a suitable work surface.

CAUTION!

When disassembling the plug, provide adequate support to avoid bending or damaging the stem or trim. Protect them by using a solid block as a backup while removing the pin from the plug.

5. Using a punch or 1/8 drift pin, drive the pin from the stem and unscrew the plug from the stem.

6. Pull the seat/ cage from the valve body. In order to remove it, it may be necessary to hook one of the cage flow openings and pull it. A seat/ cage removal tool is available from Norriseal.

B. **With the Acuator Previously Removed from the Valve**

CAUTION!

Use care to avoid damaging O-ring sealing surfaces. Assume all of these parts are in good condition when disassembling the valve and protect them accordingly. The surface finish of the valve stem is critical for creating a reliable packing seal. The bore of the seat/ cage is critical for smooth operation of the valve plug. The seating surfaces of the valve plug and seat/ cage are critical for tight shutoff.

1. Disassemble the actuator by following the procedure in Section 2.1.

2. Unscrew the hammer nut (turning COUNTERCLOCKWISE) from the valve body by striking the lugs with a hammer, and remove it from the bonnet.

3. Remove the bonnet from the valve body along with the stem and plug.

CAUTION!

When disassembling the plug, provide adequate support to avoid bending or damaging the stem or trim. Protect them by using a solid block as a backup while removing the pin from the plug.

4. Using a punch or 1/8 drift pin, drive the pin from the stem and unthread the plug from the stem.

5. Pull the seat/ cage from the valve body. In order to remove it, it may be necessary to hook one of the cage flow openings and pull it. A seat/ cage removal tool is available from Norriseal.

6. Remove the packaging washer, spring and retainer from the packing plug. Pull the valve stem out of the bonnet.

7. Use a hook-shaped tool to remove the packing and O-ring. Remove stem bushing.

CAUTION!

Use care to avoid damaging or scratching the bonnet bore.

2.4 Trim Inspection

1. While examining the valve plug and seat, use a magnifying glass to look for signs of erosion, pitting, scratches and damage from corrosion.

2. Fit the plug and the seat together. Lift the seat up to a light and look through the hole at the bottom. If any light can be seen between the plug and seat contact surfaces this is an indication of a poor fit.

3. Determine the severity of the damage. It is likely the plug and seat contact surfaces can be fully restored by re-lapping. Replace any parts that are beyond restoration.

4. Examine the stem for pitting, scratches or damage in an area adjacent to the packing and O-ring. If worn, replace the stem.

**TABLE 2
LAPPING COMPOUNDS***

TRIM MATERIAL	LAPPING MATERIAL
300 Series SST 17-4PH SST Stellite (Alloy 6)	Clover* Boron-Carbide Grade 2A
Tungsten Carbide	9U Heavy Diamond

*Equivalent products from other manufacturers may be used.

2.5 Trim Restoration

CAUTION!

Trim that has been lapped too much will widen the lap band and reduce the force of the plug seating.

Lap the plug to the seat. *NOTE: This process does not apply to plugs with soft-seat inserts.*

1. Clean plug and seat in solvent and wipe dry.
2. Select the appropriate lapping compound as shown in Table 2.
3. Using a stir stick or similar device, apply lapping compound sparingly on 3 or 4 places, approximately equidistant along the seat surface on the plug. *NOTE: The use of excess compound runs the risk of uneven lapping of the surfaces.*
4. Once the compound has been applied using the stem, fit the seat against the plug and begin

lapping the trim by pressing firmly with your hands while rotating, in a back and forth motion, against the stationary plug.

5. The seat will have a circular uninterrupted lap band not exceeding 1/32” in width at the base of the seating’s beveled edge.
6. The plug will have a definite continuous lap band that is approximately the same width as the plug without being grooved.
7. You are done when the lap areas of the seat and plug have a continuously smooth, close grained, dull appearance with no skips or tears.
8. Once finished, wash the plug and seat in solvent to remove all lapping compound and wipe the parts dry.
9. Under a bright light, visually inspect the lapped contact surfaces of the seat and plug.

2.6 Valve Re-Assembly

CAUTION!

If the packing is to be re-used and was not removed from the bonnet, use care when re-installing the valve stem to avoid damaging the packing with the stem threads.

NOTE: Install and lubricate all new O-rings prior to re-assembly

Re-assemble the valve by reversing the order of the disassembly procedure in Section 2.3.

3.0 Repair Kits

Norriseal provides four repair kits for use in valve maintenance: a valve repair kit, a valve seal kit, a trim repair kit, and an actuator repair kit. Contact the Norriseal sales office or your local sales representative to order one of these kits.

4.0 Trouble Diagnosis

WARNING!

Some of the following trouble-shooting techniques require the removal or disassembly of components normally under pressure. Before beginning any repair, be certain that all pressure(s) have been relieved from the device in accordance with the INTRODUCTION and other section references in this manual.

4.1 Internal Leakage Problems

Symptom	Probable Cause(s)	Corrective Action(s)
1. In the closed position, the valve leaks process fluid from inlet to outlet port.	<ul style="list-style-type: none"> Reverse-acting (fail-closed) actuator has insufficient spring tension Direct-acting (fail-open) actuator has excessive spring tension or insufficient actuator supply, or both 	<ul style="list-style-type: none"> Slowly increase the spring tension (refer to 1.8 A) and watch for the leak to stop. Decrease the spring tension (refer to 1.8 B) to the minimum necessary to achieve full opening at operating conditions and/or increase actuator supply pressure (refer to 1.7). Watch for the leak to stop.
	<ul style="list-style-type: none"> Direct-acting (fail-open) actuator thrust out-put diminished due to: <ol style="list-style-type: none"> failed O-ring around upper stem or, punctured actuator diaphragm. 	<ul style="list-style-type: none"> Apply supply pressure to actuator then remove the spring cover (refer to 1.8B). Check for leakage around the: 1) O-ring – where the upper stem enters the upper diaphragm house and 2) diaphragm – from the opening of the vent plug installed in lower diaphragm housing. Apply leak-detector (soapy water) if necessary. Disassemble actuator (refer to 2.1 A), inspect and replace seal component(s) as necessary.
	<ul style="list-style-type: none"> Worn or damaged valve trim (plug and seat) or failed seat/ cage-to-body O-ring. 	<ul style="list-style-type: none"> Remove the actuator assembly at its hammer nut (refer to 2.3 A) and the seat/ cage from its body. Inspect the valve trim (refer to 2.4) and O-ring seal components. Restore (by lapping) trim and/or replace component(s) as necessary.
	<ul style="list-style-type: none"> Differential pressure shut-off requirement exceeds the thrust output available from the actuator. 	<ul style="list-style-type: none"> First, record the valve serial number, model number, flow direction, current trim size and service conditions. Then call your Norriseal representative to verify actuator sizing and shut-off capability.
2. Process fluid leaks into lower diaphragm housing (Series 2220 only).	<ul style="list-style-type: none"> Bonnet-to-valve stem packing and bonnet-to-valve stem O-ring failed. The valve stem may be worn or damaged. If you cannot see the leak outside of the pipe, the bonnet weep hole is plugged. 	<ul style="list-style-type: none"> Disassemble the actuator (refer to 2.1) and valve (refer to 2.3 B). Inspect the O-ring and the sealed surfaces of the bonnet and stem. The packing must have some installation fit interference with both. Replace worn component(s) as necessary. If the bonnet weep hole is plugged than clean it out.

OPERATING AND MAINTENANCE MANUAL

Series 2200/2220 – 1.0” & 2.0”

4.2 External Leakage Problems

Symptom	Probable Cause(s)	Corrective Action(s)
1. Process fluid is leaking from the bonnet weep hole.	<ul style="list-style-type: none"> The bonnet-to-valve stem packing failed and the valve stem may be worn or damaged. 	<ul style="list-style-type: none"> Disassemble the actuator (refer to 2.1) and valve (refer to 2.3B). Inspect bonnet and stem sealing surfaces. The packing must have some installation fit interference with both. Replace the worn component(s) as necessary.
2. Process fluid is leaking from between the hammer nut and bonnet and/or valve body.	<ul style="list-style-type: none"> Bonnet-to-valve body O-ring failed. 	<ul style="list-style-type: none"> Remove the actuator assembly at the hammer nut (refer to 2.3 A). Inspect the O-ring and sealing surfaces of the bonnet and valve. Replace the worn component(s) as necessary.
3. In Reverse-acting (fail-closed) Actuators only: Supply pressure leaks from around the actuator stem at the top of the yoke window opening (Series 2200) or from the bonnet weep hole (Series 2220).	<ul style="list-style-type: none"> The actuator stem-to-yoke O-ring failed (Series 2200) or the valve stem-to-bonnet O-ring failed (Series 2220) 	<ul style="list-style-type: none"> Series 2200: Disassemble the actuator (refer to 2.1 B) and inspect the O-ring, yoke and actuator stem sealing surfaces. Series 2220: Disassemble the actuator (refer to 2.1B) and valve (refer to 2.3B) and inspect the O-ring, bonnet and valve stem sealing surfaces. For either series, replace any worn components.
4. Direct-acting (fail-open) actuator only: Supply pressure leaks from around the base of the spring cover on top of the upper diaphragm housing.	<ul style="list-style-type: none"> The actuator stem-to-upper diaphragm housing O-ring failed. 	<ul style="list-style-type: none"> Disassemble the actuator (refer to 2.1A) and inspect the O-ring, back-up ring and sealing surfaces of the stem and housing bore. Replace the worn component(s) as necessary.
4. Supply pressure is leaking from the diaphragm housing vent plug when the valve is not moving.	<ul style="list-style-type: none"> The Actuator diaphragm is punctured. 	<ul style="list-style-type: none"> Disassemble the actuator (refer to 2.1) and replace the diaphragm and diaphragm-to-diaphragm plate O-ring.

4.3 Valve Performance Problems

Symptom	Probable Cause(s)	Corrective Action(s)
1. The valve will not open completely (reverse-acting fail-closed actuator) OR the valve will not close completely (direct-acting fail-open actuator).	<ul style="list-style-type: none"> Troubleshoot to find an actuator seal leakage (refer to 4.2, Symptoms 3, 4 and 5) The actuator spring has excessive tension or the supply pressure is too weak to override the spring (or both). 	<ul style="list-style-type: none"> See the corrective actions in section 4.2. Decrease spring tension (refer to 1.8) until full flow is achieved; increase the actuator supply pressure (refer to 1.7) if required.
2. The valve is fully closed and will not open.	<ul style="list-style-type: none"> The supply pressure line is connected to the wrong side of the actuator or the reverse-acting (fail-closed) actuator spring is completely compressed resulting in the inability to lift the valve plug. 	<ul style="list-style-type: none"> Make sure the actuator's supply pressure source line is connected to the lower diaphragm housing. Then decrease the spring tension (refer to 1.8A) until valve is open far enough to allow full travel.

4.3 Valve Performance Problems (continued)

Symptom	Probable Cause(s)	Corrective Action(s)
2. The valve is fully closed and will not open. (Continued)	<ul style="list-style-type: none"> The direct-acting (fail-open) actuator cannot vent supply pressure due to a non-relieving pressure source device. Troubleshoot by following section 4.3 -2A to eliminate those items as problems. In a reverse-acting (fail-closed) actuator, the supply pressure may be the problem and in a direct-acting (fail-open) actuator, the spring tension may be insufficient to open the valve plug (the tension may not be enough to overcome the static differential pressure holding the plug closed). The static differential pressure combined with the trim size and the direction of the inlet “flow-over” may exceed the available thrust of the actuator opening. 	<ul style="list-style-type: none"> Replace the supply pressure source device with one that relieves pressure or install a 3-way vent valve at the actuator supply connection. Follow the corrective actions suggested in Section 4.3 – 2A. If you have a reverse-acting (fail-closed) actuator, increase the supply pressure. If you have a direct-acting (fail-open) actuator, increase the spring tension. For both, an increase in supply pressure may be require to re-close the valve.(refer to 1.7) Record the valve’s serial number, model number, current trim size and services conditions. Contact your Norriseal Representative to verify actuator sizing and shut-off capability.
3. The valve will not close. It is stuck fully open.	<ul style="list-style-type: none"> In a reverse-acting (fail-closed) actuator, the supply pressure cannot be vented due to a non-relieving pressure source device. The supply pressure line is connected to the wrong side of the actuator. If it’s a direct-acting (fail-open) actuator, the spring may be fully compressed and unable to create valve plug movement. 	<ul style="list-style-type: none"> Replace the supply pressure source device with one that is able to relieve pressure, or install a 3-way vent valve at the actuator supply connection. Make sure that the actuator supply pressure source line is connected to the upper diaphragm housing. Decrease the spring tension (refer to 1.8B) to the minimum necessary to achieve full opening at operating conditions.
4. The valve movement is sluggish or unusually slow.	<ul style="list-style-type: none"> There may be actuator seal leakage (refer to 4.2, symptoms 3, 4, or 5) The opening of the diaphragm housing vent plug is partially blocked. If you just installed the valve, the actuator supply pressure volume may be too low. If the valve has been in use for a while, the volume has diminished over time due to clogged openings and/or filters in control devices/ regulators. 	<ul style="list-style-type: none"> Perform the correlating (3, 4 or 5) corrective action suggested in 4.2. Remove the vent plug and unclog the opening Increase the supply pressure line size and/ or install a volume booster. Clean the openings and clean/ replace the filters of the control devices according to the manufacturers’ recommendations.

4.3 Valve Performance Problems (continued)

Symptom	Probable Cause(s)	Corrective Action(s)
<p>5. The inlet flow direction is over the seat and the trim size is ½” or larger (**this is generally applicable to throttling service only)</p> <p>On initial opening, the valve instantaneously travels to full open or near full open position (there is no valve position control over travel range).</p>	<ul style="list-style-type: none"> The actuator opening thrust required (by overcoming static differential pressure) to open the valve plug is greater than the opposing actuator spring force (tension) adjustment. The spring force (tension) requirement for the particular service conditions exceeds the capabilities of the actuator being used. 	<ul style="list-style-type: none"> Slowly increase the spring tension (refer to 1.8) and check the movement of the valve opening. Slowly increase the tension until the valve plug lift is controllable. An increase in the actuator supply pressure (refer to 1.7) may also be required. Write down the valve serial number, model number, current trip size and service conditions. Then contact your Norriseal representative to verify the actuator sizing.
<p>6. Generally applicable to throttling service only:</p> <p>The closed valve is leaking or will not open against static differential pressure even with the actuator spring tension adjusted to correspond with the control instrument signal start point (3 psig if in the 3-15 range, 6 psig if in the 6-30 range). (refer to 4.3, #5 – SYMPTOM and PROBABLE CAUSE)</p>	<ul style="list-style-type: none"> The actuator spring force (tension) necessary to achieve a tight shut-off OR overcome the static differential pressure holding the valve plug closed against the seat is more than the force coming from the actuator (3-15 psig) or the supply pressure (6-30 psig). 	<ul style="list-style-type: none"> Record the valve serial number, model number, current trim size and service conditions. Then contact your Norriseal representative to verify that the actuator has sufficient thrust capability. You may need a valve positioner to: <ol style="list-style-type: none"> Achieve accurate valve response to the control instrument signal that a simple spring tension adjustment would not fix. Make use of all available actuator thrust for shut-off up to the maximum actuator rating.

5.0 Valve Body Styles and Port Orientation Markings

The Styles

The Series 2200 and 2220 valves are available in three valve body styles:

- **THE GLOBE:** This style comes in 1” and 2” valve sizes and has two process piping connections—one on each side.
- **THE ANGLE:** This style is available in 1” (using a tee style body) and 2” valve sizes and has two process pipe connections— an upper port side connection and a lower port bottom connection.
- **THE TEE:** This style is only available in the 1” valve size.

The female threaded NPT body has

three connections—one on each side located in-line (like the globe style) and an additional bottom connection located in the center (it shares the lower port passageway) and has a pipe plug installed to permit field conversion to either a globe or angle flow pattern. The tee body is also used for 1” angle pattern flanged, socket-weld and butt-weld bodies. The unused side port is permanently plugged and welded closed.

The Body Markings and Port Orientation

On the outside of the globe and tee valve bodies you will find a **BRIDGE SYMBOL** cast. This image repre-

sents the position of the internal cast web (or bridge) separating the lower port-flow passage from the upper port-flow passage. The Series 2200/2220 valve can be installed with the **inlet** fluid flow directed into the body’s **lower port** (“**flow under seat**”) or **upper port** (“**flow over seat**”). This is the reason a bridge symbol is used instead of a direction arrow. Issues regarding your valve’s performance are often because of the direction fluid is flowing through the valve body. The illustrations below define how the bridge symbol geometry and the internal port orientation of the valve body work together.

TABLE 3—BRIDGE SYMBOL AND VALVE BODY PORT ORIENTATION

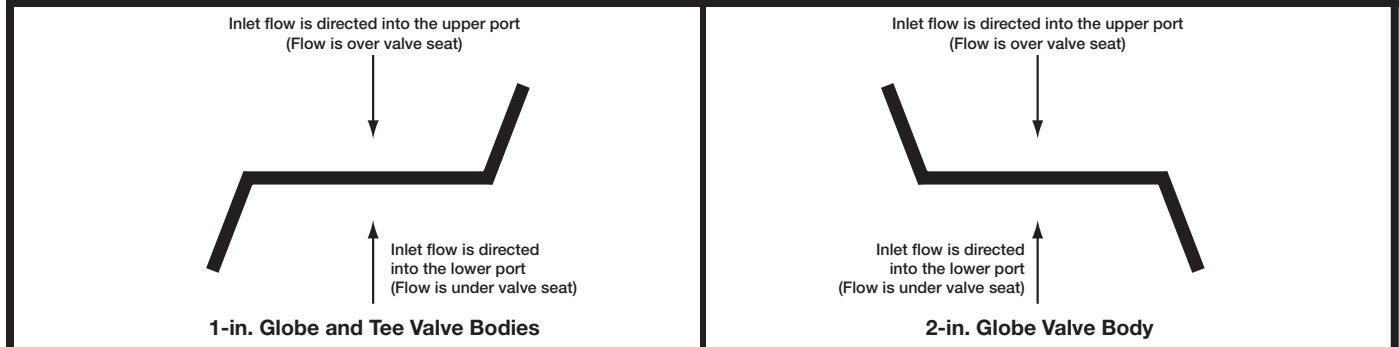

OPERATING AND MAINTENANCE MANUAL

Series 2200/2220 – 1.0” & 2.0”

This page intentionally left blank.

HEADQUARTERS, MANUFACTURING PLANT AND SALES



www.norriseal.com

11122 West Little York • Houston, Texas 77041

T: (713)466-3552 • F: (713)896-7386

*Due to the continuous improvement at Norriseal,
specifications and/or prices are subject
to change without notice or obligation.*