

OPERATING AND MAINTENANCE MANUAL

Series 1100A – Liquid Level Switches

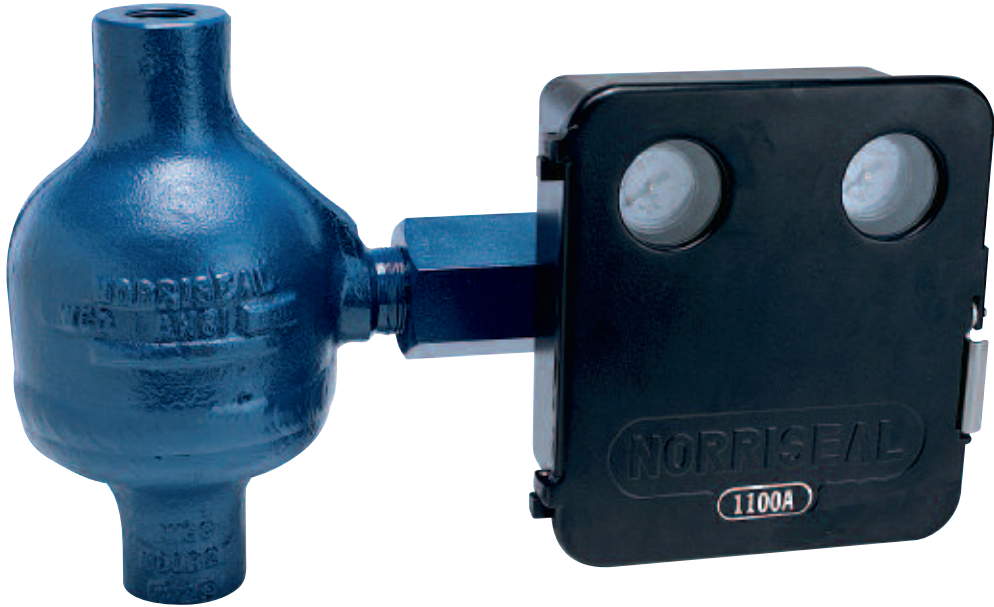

Series 1100A

TABLE OF CONTENTS

1.0 MODEL INTRODUCTION	1
1.1 Model Designation	1
1.2 Specifications	2
1.2.1 Materials of Construction	2
1.2.2 Configuration	3
2.0 INSTALLATION AND START-UP	3
2.1 Orientation	3
2.2 Configuration	4
2.3 Start-up	5
3.0 OPERATION	5
3.1 Principle Of Operation	5
3.2 Snap Pilot	6
3.3 Relief Pilot	6
3.4 Electric Pilot Switches	6
3.4.1 Circuitry	7
3.4.2 Enclosure	8
3.5 Control Adjustments	8
3.5.1 Level	8
3.5.2 Sensitivity	8
3.6 Case Mounting and Action Conversions	8
3.6.1 Pilot Action	8
3.6.2 Case Mounting	9
3.7 Dimensions	10
4.0 MAINTENANCE	14
4.1 Preventive Maintenance	14
4.2 Basic Electric Switch	14
4.3 Troubleshooting	15
5.0 PARTS LIST	16

OPERATING AND MAINTENANCE MANUAL

Series 1100A – Liquid Level Switches

CAUTION!

Before disassembly or maintenance, all pressures in this device must be relieved. Failure to relieve pressures may result in personal injury or device damage. The resulting uncontrolled venting or spilling of line fluids may cause personal injury, loss of process control or environmental contamination.

1.0 MODEL INTRODUCTION

1.1 Model Designation

Model 1 SC 14 – SRDF – A E

END CONNECTIONS	
Size	Code
1.00"	1
1.50"	15
2.00"	2

END CONNECTIONS	
Type	Code
NPT (Screwed Female)	SC
Socket Weld	SW
Butt Weld SCH 40"	B4
Butt Weld SCH 80"	B8
Butt Weld SCH 160"	B1
Flanged Raised Face	RF
Flanged Ring Type Joint	RJ

PRESSURE RATING		
ANSI	Rating	Code
150	285	2
300	740	7
600	1480	14
900	2220	21

MATERIAL			
Body/Chamber	Shaft/Bearing	Displ.	Code
A696/WCC	303	304L	–
A696/WCC (NACE)	316	A20	N
A276/CF8M (NACE)	316	A20	R
A276/CF8M	316	316	S
A276/CF3M	316	A20	T
A696/WCC	316	316	Y

PILOT MODE	
Mode Type	Code
Electric DPDT X-Proof	D
Electric SPDT X-Proof	E
Electric DPDT Splash Proof	F
Electric SPDT Hermetically Sealed	K
Electric DPDT Hermetically Sealed	L
Pneumatic Relief w/Gauges	R
Pneumatic Snap w/Gauges	S
Electric SPDT Splash Proof	O

MOUNTING CASE	
Mounting Type	Code
Left Hand	L
Right Hand	R

CASE OPTIONS	
Code	Options
A	Case Extension (Seal Material - Specify Hi Temp or Low Temp)
N	Viton Case & Pilot Seal

CLOSURE – CASE	
Code	Type
B	Sealed Case/Cover Only
C	Sealed Case/Cover and Piped Exhaust
D	Sealed Case/Cover, Piped Exhaust and Special Marine Internals
E	Sealed Case/Cover and Special Marine Internals

SERVICE CONDITION	
Code	Service
A	Standard/Standard Gauges
B	Vibration/Standard Gauges
C	Vibration/Vibration Gauges
D	Vibration/Liquid Filled Gauges

PROCESS CONNECTION ORIENTATION	
Code	Service
–	NPT – Specify Plug Placement
A	Side Top/Side Bottom
B	Side Top/Bottom
C	Top/Side Bottom
D	Top/Bottom
E	All Four Connections

SEAL BEARING MATERIAL			
Code	O-Ring	Bearing	Temp (°F)
E	EPR	303 SST	275
F	Viton	303 SST	400
L	Buna	303 SST	180
S	Aflas	316 SST	400

PILOT ACTION	
Code	Action Type
R	Reverse Acting
D	Direct Acting

Series 1100A – Liquid Level Switches

1.2 Specifications

PILOT • PNEUMATIC

Output:

Snap: 0-20 psig
0-30 psig
Relief: 0-30 psig
0-50 psig

Supply Pressure Requirement

0-20 psig: 20-30 psig (min)
0-30 psig: 35-40 psig (min)
0-50 psig: 60 psig (max)

Pilot Capacity

Snap C: 0.282
Relief C: 0.403

Air Consumption

The Snap Pilot is a metal seated “No Bleed” Force-Balance device, where steady state consumption is virtually dependent on frequency of switching operation resulting from liquid level changes.

The Relief Pilot has an elastomeric o-ring seat; thus achieving an absolute steady state “Bubble Tight” seal. Air consumption is entirely dependent on frequency of switching operation.

Proportional Band Adjustment* -

(Recommended adjustment for a full output pressure change over a percent of sensing element)

Snap: 7-35%
Relief: @30psi Supply=10-35%
@50 psi Supply =15-55%

Supply and Output Connection:

1/4 inch NPT Female

PILOT - ELECTRIC - ON/OFF

Output:

Circuitry and Rating:

See Section 3.5

Enclosure:

See Sections 3.5.1, 3.5.2, and 3.5.3

Proportional Band Adjustment (Electric - Micro Switch)

SPDT: 6-30%
DPDT: 30-700/0

(Electric - Hermetically Sealed)

SPDT: 6-30%
DPDT: 30 - 70%

Specific Gravity - Minimum

Snap or SPDT Micro or
Hermet: 0.05
Relief: 0.06
DPDT Micro:
0.07

Conduit Connection:

1/2" NPT Female

Process Pressure Rating:

See Section 1.4

Temperature Limits

Body/Chamber (dependent on material selection-See Section 1.3)
-70 to +400 °F

Instrument Case

Pneumatic Pilot Ambient
Temperature: -40 to +180 °F -40 to +275 °F (High Temp)

Electric Pilot Ambient Temperature:

-40 to +160 °F

A Case Extension is used for extreme process temperatures or when body insulation is to be used.

*The performance characteristics published are based on tests using a STD Series 1100A Model 1 SO4-SRDF-AE operating in 1.0 specific gravity liquid at 80°F temperature, and 100 psig pressure.

Performance characteristics may vary depending on application.

1.2.1 Materials of Construction

Body/Chamber

ASTM A696/A216 WCC

(-20 to +400°F) ASTM

A276/A351 CF8M

(-70 to +400 °F) ASTM

A276/A351 CF3M

(-70 to +400 °F)

Displacers

304L SST (-70 to +400°F)

316 SST (-70 to +400°F)

Alloy 20 (-70 to +400°F)

Displacer Arm

303 SST (Standard)

316 SST (Optional)

Shaft

303 SST (Std -70 to +400°F)

316 SST (Opt -70 to +400°F)

Bearing Blocks

303 SST (Std -70 to +400°F)

316 SST (Opt -70 to +400°F)

Bearings

440C SST (-70 to +400°F)

Shaft Seals

Nitrile (-50 to +180°F)

Nitrile Lo-Temp (-70 to +180°F)

Fluorocarbon (-20 to +400°F)

Aflas (-20 to +400°F)

EPR (-70 to +250°F)

Case & Cover

Die Cast Anodized Aluminum, with Enamel Paint

Pilot - Pneumatic

Relief: Aluminum w/Elastomer Seat

Snap: Aluminum Seat

Gasket/Diaphragm

Nitrile (Standard)

Fluorocarbon (Optional)

Internal Valving

303 SST

Filter Element

40 micron Phenolic Resin

Impregnated Felt

OPERATING AND MAINTENANCE MANUAL

Series 1100A – Liquid Level Switches

Screws & Nuts

SST

Supply & Output Gauges (0-60 PSIG)

Brass (Standard)

316 SST (Optional)

Brass Liquid Fill (Optional)

316 SST Liquid Fill (Optional)

Pilot - Electric

Micro-Switch Enclosure:

Cast Aluminum

Hermet Switch Enclosure:

SST

Junction Box:

Cast Aluminum

Torque Bar

303 SST Aluminum (Optional)

Flapper Bar

303 SST

Spring Adjusting Knob

303 SST

Aluminum (Optional)

Fulcrum

Nylon w/Zinc Screw (Standard)

Nylon w/SST Screw

(Optional/Marine)

Balancing Spring

SST

1.2.2 Configuration

Chamber End Connections

Sizes (Pipe):

1.0", 1.50" and 2.0"

Beveled - Butt Weld & Socket Weld:

To 2220 PSIG

NPT Threaded (1.0" ONLY):

To 2220 PSIG

Flanged (RF & RTJ):

150 thru 900 ANSI CLASS

Case Mounting - 1100A (Facing the Front Side)

Right Hand - Where the chamber is to the right of the case.

Left Hand - Where the chamber is to the left of the case.

Pilot Action: Field Reversible

Between Direct Acting:

Increasing Level

Increases Output

Opens contacts on falling level/vents on falling level.

and Reverse Acting:

Increasing Level

Decreases Output

Opens contacts on rising level/vents on rising level.

Balancing Spring

Light: Green

Medium: None

2.0 INSTALLATION AND STARTUP

2.1 Orientation

The following drawings illustrate the standard configurations of the Norriseal Level Switch.

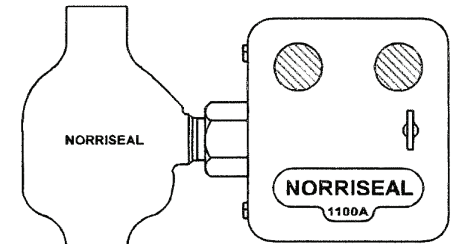

1.00" NPT Process Connections

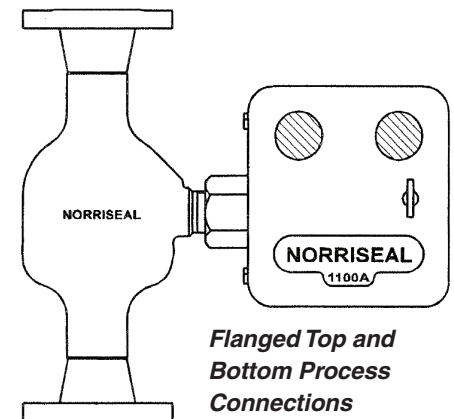

Flanged Top and Bottom Process Connections

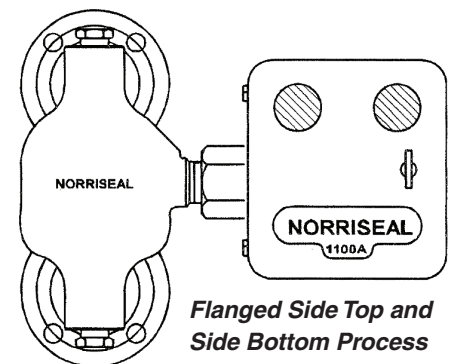

Flanged Side Top and Side Bottom Process Connections

2.2 Configuration

The following drawings illustrate some of the standard configurations of Norriseal's level switches. Utilize these drawings to verify that your level switch is properly configured.

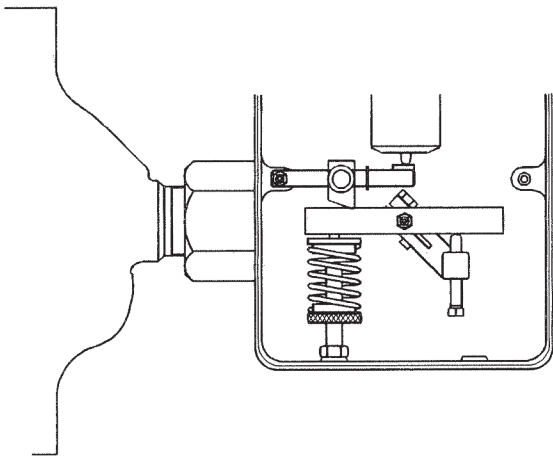

**Left Hand Mount — Direct Acting
Rising Level Increases Pilot Output**

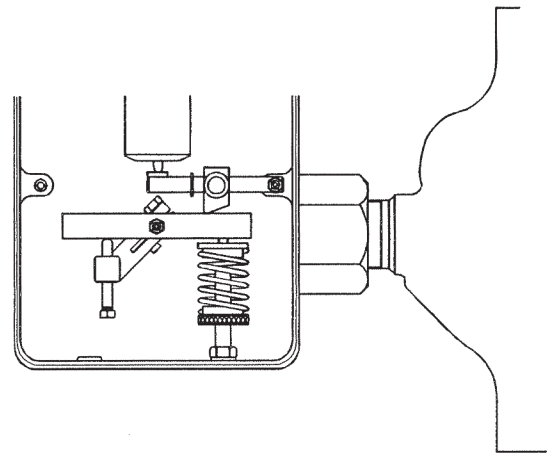

**Right Hand Mount — Direct Acting
Rising Level Increases Pilot Output**

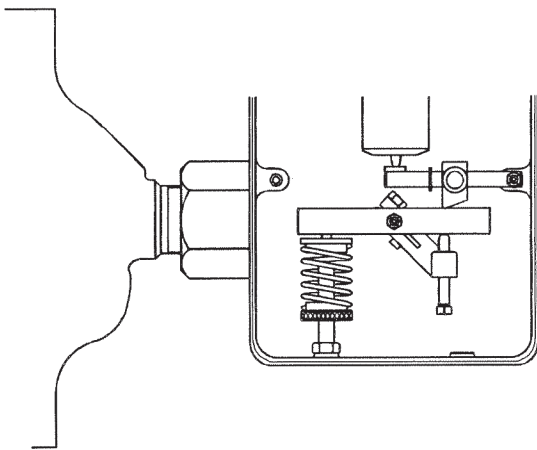

**Left Hand Mount — Reverse Acting
Rising Level Decreases Pilot Output**

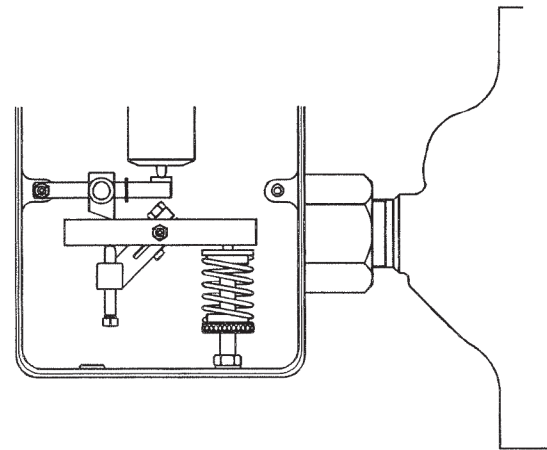

**Right Hand Mount — Reverse Acting
Rising Level Decreases Pilot Output**

2.3 Start-Up

The Series 1100A Liquid Level Switch is a combination of the Norriseal Series 1001A LLC and Vertical Cast Steel Pre-assembled Displacer Cage. The Series 1100A assembly is installed in a vertical position with NPT Threaded, Flanged, Butt-weld or Socket Weld connections. The Series 1100A Liquid Level Switch is furnished with either a pneumatic pilot (snap or relief) or an electric pilot (SPDT or DPDT).

The level switches are shipped and pre-assembled.

1. Remove the shipping plugs from the chamber before installation and connect the chamber to the vessel.
2. Rock the torque bar by hand to verify that the displacer is not bumping against the chamber bottom or top.
3. The displacer must be reasonably centered in the chamber. Turn the adjusting knob under the balance spring to lift or lower the displacer position.
4. For a pneumatic pilot, the minimum differential span of fluid level change is achieved when the sensitivity fulcrum is positioned at "1". For an electric pilot, set the sensitivity fulcrum at position "2" for minimum differential span.

TO LOWER THE LEVEL, turn the adjusting knob **CLOCKWISE** to increase compression on the balance spring.

TO RAISE THE LEVEL, turn the adjusting knob **COUNTER CLOCKWISE** to decrease compression on the balance spring.

TO ADJUST THE PROPORTIONAL BAND (SPAN), loosen the thumb screw in the fulcrum and slide the fulcrum along the flapper bar. To **DECREASE** the proportional band (**INCREASES SENSITIVITY**), slide the fulcrum toward the snap ring. To **INCREASE** the proportional band (**DECREASES SENSITIVITY**), slide the fulcrum away from the snap ring.

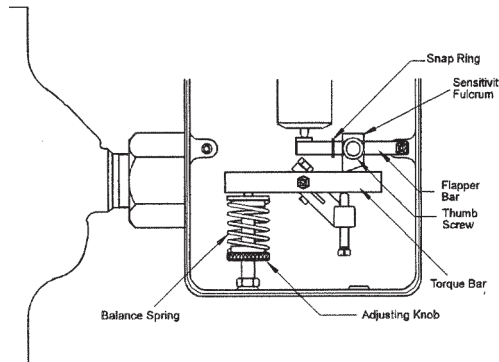

3.0 OPERATION

3.1 Principle Of Operation

A spring balances the weight of a displacement type sensing element. As liquid rises around the displacer, the amount of force made available to the pilot is proportional to the volume of liquid displaced. The higher the liquid level, the greater the force available to the pilot thrust pin. This direct-acting force is easily reversed in the field.

The force available is transmitted to the pilot thrust pin through a lever and fulcrum. The control is **direct acting** (rising level increases pilot output) when the pivot point of the lever is on the spring side of the control case.

The control is **reverse acting** when the pivot point is on the opposite side of the control case from the spring (rising level decreases pilot output).

Adjusting Proportional Band

Proportional band is the ratio of used displacer to total diameter of displacer. (ex: If 2.0 inches of level change will develop a 0-20 psi output signal with a 4.0 inch diameter displacer, the level controller is said to have a 50% proportional band. By moving the fulcrum closer to the pivot point you increase the proportional band. By moving the fulcrum toward the snap ring you decrease the proportional band. A full output signal may be obtained over any portion of the displacer by adjusting the fulcrum as described.

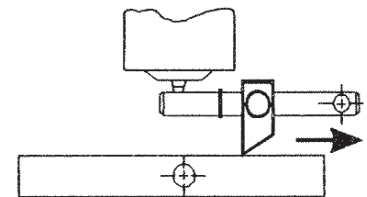

Increase Proportional Band

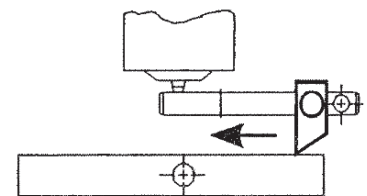

Decrease Proportional Band

Adjusting Level

Assuming the spring force is held constant, the higher the liquid level on the displacer the greater the force available to the pilot. When spring force is reduced (by decompressing the spring), a higher level on the displacer is required to produce the same force as before.

3.2 Snap Pilot

The snap pilot is comprised of two metal seated valves – one to admit (D) pilot supply pressure and one to exhaust (C) pressure.

The ball (A) controls the flow of instrument air into the pilot at the seat (D) and is held closed with force exerted by supply pressure on the seating area of the ball.

When the upward mechanical force transmitted to the thrust pin (B) is sufficient to overcome the force holding the ball (A) seated, it snaps upward allowing instrument air to flow past it and to the output port (H) of the pilot.

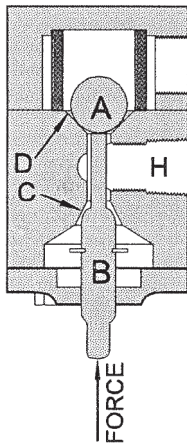

The spherical end of the thrust pin (B) closes the exhaust port (C) the instant the ball (A) snaps upward. The exhaust port seating area (C) is smaller than the seating area of the supply port; therefore, the push rod must remain seated against the supply pressure until the force on the thrust pin (B) diminishes.

As the force acting on the thrust pin (B) is reduced, the supply pressure acting downward on the ball (A) overcomes the upward force at the thrust pin (B) and reversing action occurs. The ball (A) closes the supply pressure at valve D and opens the exhaust port at valve C, thus venting gas from the port (H). The snap action results from the differences in seating areas of the two internal pilot valves.

3.3 Relief Pilot

The relief pilot used in the block & bleed system operates identically to the snap pilot, with the exception of two differences. The seat (D) has an added resilient seal (F) and the flow passage (G) is enlarged.

The seat seal (F) is an elastomeric O-ring which gives an absolute “zero leakage” seal of supply pressure at the ball (A). Just as in the snap pilot, when upward mechanical force transmitted through the thrust pin (B) exceeds the downward force of the supply pressure at the seat (D), the ball (A) snaps upward, allowing instrument air to flow past the ball (A) and to the port (H).

The flow passage (G) has a 43% larger flow capacity than the snap pilot, allowing instrument supply air to vent at a faster rate. The pilot valves will reset when the mechanical force is reduced.

The relief pilot cannot be converted into snap.

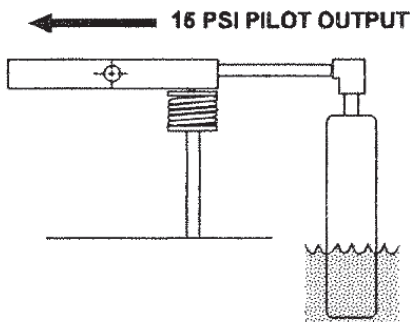
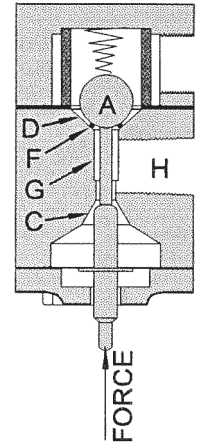

Compressing the spring lowers the level on the displacer.

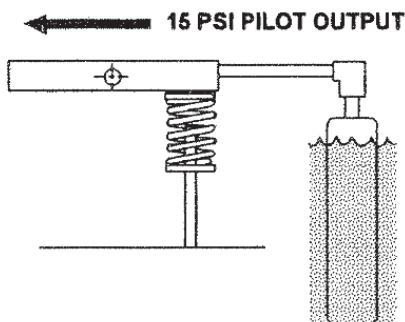

Reducing spring force raises level to provide a predetermined pilot output.

3.4 Electric Pilot Switches

Two standard switches are available, single pole double pole (SPDT) or double pole double throw (DPDT).

OPERATING AND MAINTENANCE MANUAL

Series 1100A – Liquid Level Switches

3.4.1 Circuitry

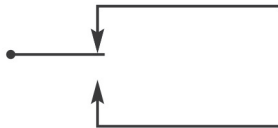
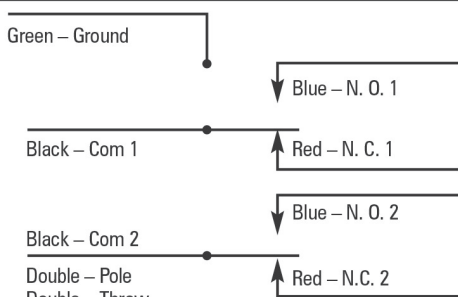
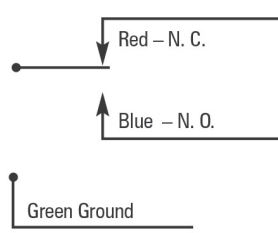
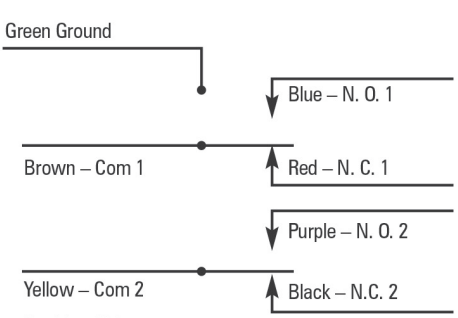
CIRCUITRY		
<i>Code</i>	<i>Micro Switch Circuitry</i>	<i>Electrical Rating</i>
"E" EX-Q or "O" OP-Q	 <p>Single - Pole Double - Throw</p>	<p>A</p> <p>UL and CSA Listed: A 15 amps, 125, 250 or 480 VAC 1/8 hp, 125 VAC; 1/4 hp, 250 VAC; 1/2 amp, 125 VDC; 1/4 amp, 250 VDC</p>
"D" EXD-Q or "F" OPD-Q	 <p>Green - Ground</p> <p>Black - Com 1</p> <p>Black - Com 2</p> <p>Blue - N. O. 1</p> <p>Red - N. C. 1</p> <p>Blue - N. O. 2</p> <p>Red - N. C. 2</p> <p>Double - Pole Double - Throw</p>	<p>B</p> <p>UL and CSA Listed: 10 amps, 125 or 250 VAC; 0.3 amp, 125 VDC; 0.15 amp, 250 VDC</p>
<i>Hermetically Sealed Switch</i>		
"K" Hermetic 030	 <p>Red - N. C.</p> <p>Blue - N. O.</p> <p>Green Ground</p> <p>Single - Pole Double - Throw</p>	<p>11 amps, 1/4 HP @ 125/250 VAC; 5 amps Res @ 28 VDC; 0.5 amps @ 125 VDC</p>
"L" Hermetic 057	 <p>Green Ground</p> <p>Brown - Com 1</p> <p>Yellow - Com 2</p> <p>Blue - N. O. 1</p> <p>Red - N. C. 1</p> <p>Purple - N. O. 2</p> <p>Black - N. C. 2</p> <p>Double - Pole Double - Throw</p>	<p>11 amps, 1/4 HP @ 125/250 VAC; 5 amps Res @ 28 VDC; 0.5 amps @ 125 VDC</p>

3.4.2 Enclosure

“EX” Explosion-Proof

Flame paths within the housings of these switches cool exploding gases below the kindling temperature before they reach explosive gases surrounding the housing.

The enclosed replaceable basic switch is accessible when the cover plate is removed. “EX” explosion-proof switches are not sealed and therefore are not recommended for use in areas where they will be subjected to liquid splash.

Micro Switch “EX” switches are listed by Underwriter’s Laboratories and CSA for use in hazardous locations Class I, Groups C&D, and Class II, Groups E, F and G. This includes vapors of ethyl ether, gasoline, petroleum, alcohol, acetone, lacquer solvent, natural gas and atmosphere charged with grain dust, metal dust, carbon black, coal or coke dust. “EX” switches also meet NEMA 1 enclosure requirements.

“OP” Splash-Proof

These switches are for use in applications where the splash of oil, water or other liquids might hamper the operation of less adequately protected switches. A gasket between the cover and housing provides the seal for “OP” switches. MICRO SWITCH “OP” switches are not explosion-proof.

“OP” switches meet the NEMA enclosure requirements of Type 1, general purpose.

Hermetically Sealed

The switches are hermetically sealed for hazardous locations listed UL & CSA Class 1, Groups A, B, C & D; Class 2, Groups E, F & G. The switch

leads are terminated in a junction box, UL listed Class 1, Groups C & D, Class 2, Group E & G.

3.5 Control Adjustments

3.5.1 Set Point – Level

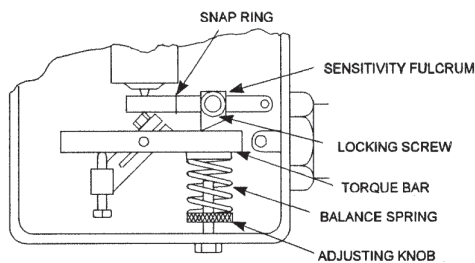

1. Compress the balance spring with adjusting knob to balance the weight of the displacer.
2. Make sure the displacer arm is not resting against the body of the chamber by rocking the torque bar.
3. To LOWER THE LEVEL, increase the spring compression. Turn the adjusting knobs to the right. To RAISE THE LEVEL, decrease the spring compression. Turn the adjusting knobs to the left.

3.5.2 Sensitivity Proportional Band

1. Loosen the locking screw on the sensitivity fulcrum.
2. TO INCREASE THE SENSITIVITY, slide the fulcrum nearer to the snap ring. TO DECREASE THE SENSITIVITY, slide the fulcrum away from the snap ring.
3. Finger tighten the locking screw.

NOTE: All switches are preset at the factory for average level and sensitivity. Normally, no further adjustment is required. The square head screw under the torque bar is used only for the fine adjustment of set points.

3.6 Case Mounting and Action Conversion

The following are instructions for the disassembly, conversion and re-assembly of all parts involved in mounting and/ or controller action of liquid level controls.

3.6.1 Pilot Action (direct to reverse or reverse to direct)

Disassembly

NOTE: location and position of parts before proceeding

1. Relax all tension on the balance spring.
2. Remove the 10-32 lock nut from the pivot pin retaining the flapper bar.
3. Slide the flapper bar from the pivot pin.
4. Remove the thumb screw from the sensitivity fulcrum.
5. Put the thumb screw in the opposite hole of the fulcrum from which it was originally removed.
6. Reverse the position of the flapper bar.
7. Slide the flapper bar on the opposite of the pivot pin from which it was originally removed. The thumb screw should be

facing outward and the fulcrum's longest side (with contact point) is closest to the snap ring on the flapper bar.

8. Install a 10-32 lock nut to retain the flapper bar. (the flapper bar must remain free to pivot)
9. Adjust the tension on the balance spring.

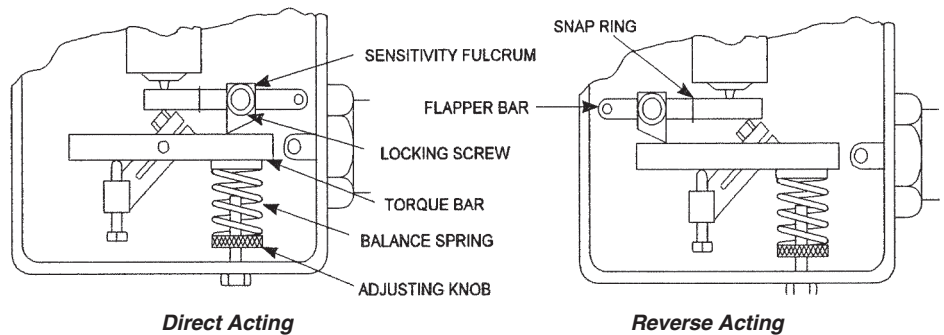

3.6.2 Procedure For Case Mounting Conversion

Disassembly

NOTE: location and position of parts before proceeding

1. Relax all tension on the balance spring.
2. Remove the balance spring and upper spring retainer from the pilot case.
3. Remove 3/8 – 24” bolt stud and lower spring retainer from the pilot case.
4. Remove the two 10-32 lock nuts. (use a 7/16 wrench)
 - a. One nut is on the end of the shaft.
 - b. One nut is on the pivot pin retaining flapper bar.
5. Slide the flapper bar from the pivot pin.
6. Slide the torque bar from the shaft.
7. Loosen the two 1/4 “ hex head cap screws in the level adjusting bar (use 1/2” box-end wrench).
 - a. Holding the level adjusting bar, loosen both screws until the level adjusting bar is free on the shaft.

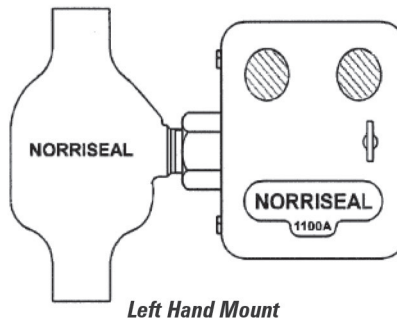

Left Hand Mount

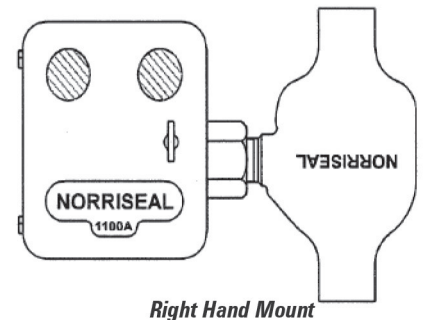

Right Hand Mount

- b. Slide the level adjusting bar from the shaft.
- c. Slide the spacer from the shaft.
8. Remove the two 1/4-28 x 3/8” hex head cap screws, (use a 1/2” socket wrench) so that the pilot case is loose.
9. Remove the case from the level control body.

Conversion and Re-Assembly (see drawings for desired mounting location)

1. Install two 1/4-28 x 3/8” hex head cap screws into case mounting holes.
 - a. Mount the case to the body with 2 screws.
 - b. Tighten the screws.

- (torque them to 6 ft./ lbs.)
2. Slide the spacer on the shaft.
3. Level the adjusting bar
 - a. Position the level adjusting screw so that there is an equal amount of thread showing above and below the bar.
 - b. Slide the level adjusting bar on the shaft against the spacer.
 - c. Snugly fasten two 1/4 - 28 x 3/8” hex head cap screws in to the bar. (Do not tighten)
 - d. Slide the torque bar on the shaft temporarily to position the level adjusting bar.
 - e. Position the level adjusting bar so that the torque bar is parallel with the displacer arm when the round tip of the level

- adjusting screw is touching the torque bar.
- f. With the level adjusting bar positioned, slide the torque bar from the shaft and tighten the two 1/4-28 x 3/8" hex head cap screws. Tighten the screw nearest the slotted end of the level adjusting bar first.
4. Slide the torque bar onto the shaft with the countersunk hole for the spring retainer facing down.
 - a. Left Hand Mount – Hole is on the left side
 - b. Right Hand Mount – Hole is on the right side.
 5. Install a 10-32 lock nut on the end of the shaft. (allow a 1/16 inch clearance between the back of the lock nut and the torque bar.)
 6. Slide the flapper bar onto the pivot pin.
 - a. Left Hand Mount – Direct Acting – use the left pivot pin.
 - b. Left Hand Mount – Reverse Acting – use the right pivot pin.
 - c. Right Hand Mount – Direct Acting – use the right pivot pin.
 - d. Right Hand Mount – Reverse Acting – use the left pivot pin.
 7. Install a 10-32 lock nut to retain the flapper bar. (Flapper bar must remain free to pivot)
 8. Install 3/8 – 24 bolt stud and lower spring retainer into the lower pilot case.
 - a. Left Hand Mount – the bolt stud is at the left side
 - b. Right Hand Mount – the bolt stud is at the right side.
 9. Install the spring and upper spring retainer, engaging the retainer with the hole in the torque bar.

3.7 Dimensions

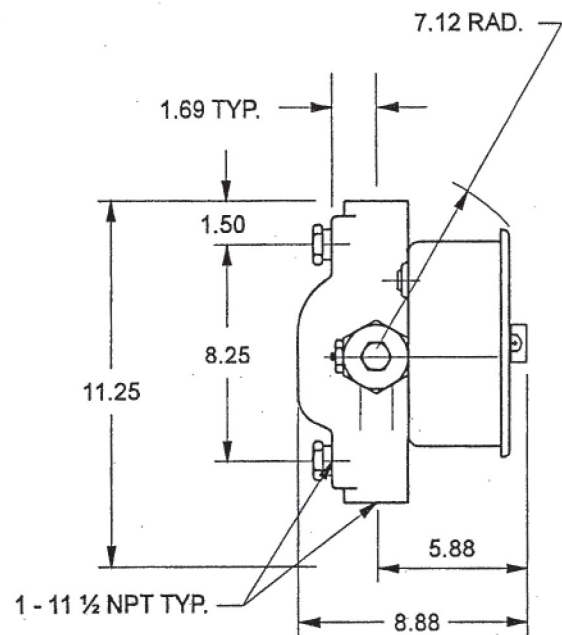
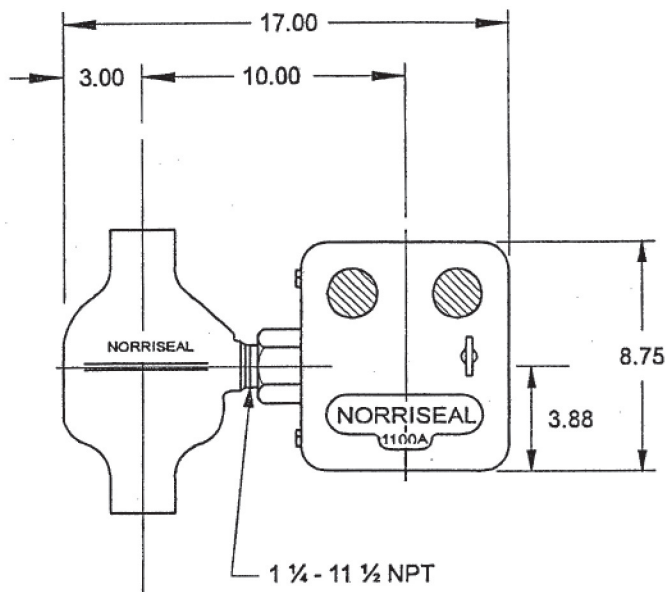

OPERATING AND MAINTENANCE MANUAL

Series 1100A – Liquid Level Switches

1/2 - 18 NPT SUPPLY & OUTPUT CONNECTIONS

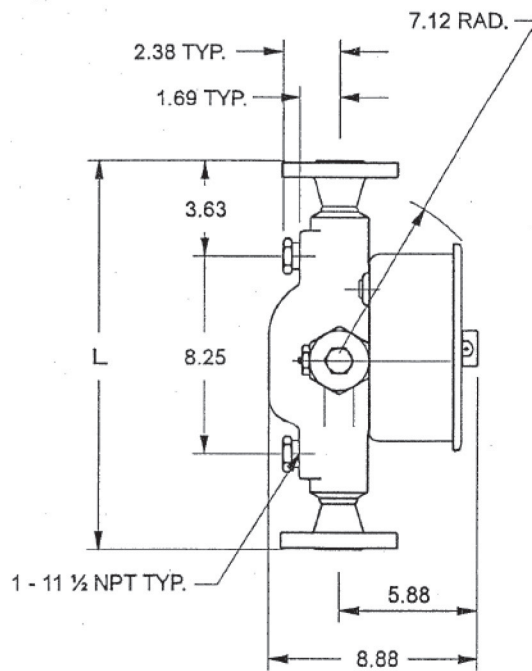
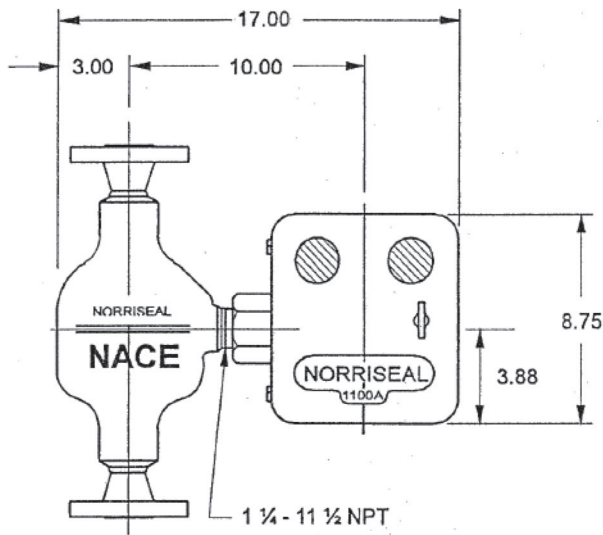
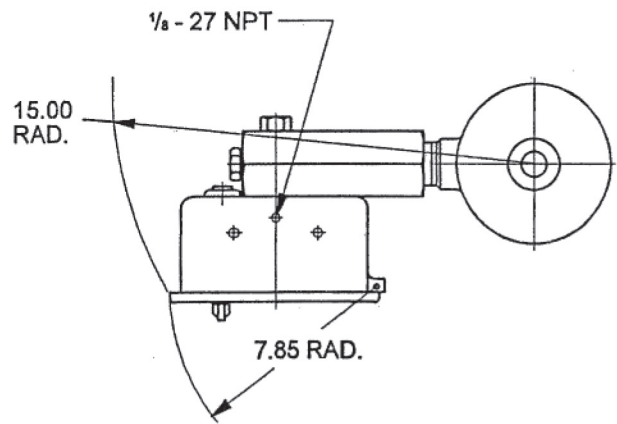
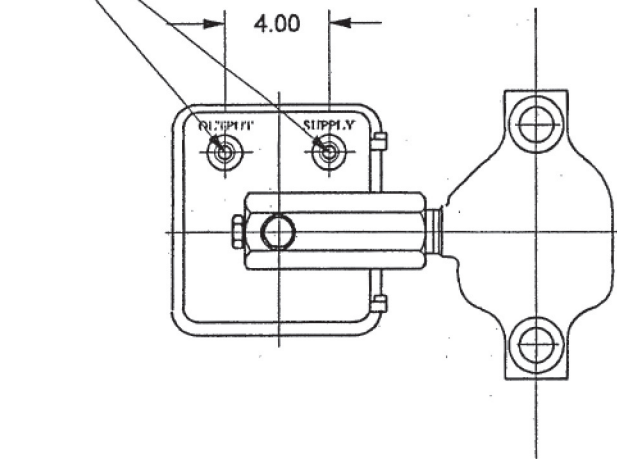

OPERATING AND MAINTENANCE MANUAL

Series 1100A – Liquid Level Switches

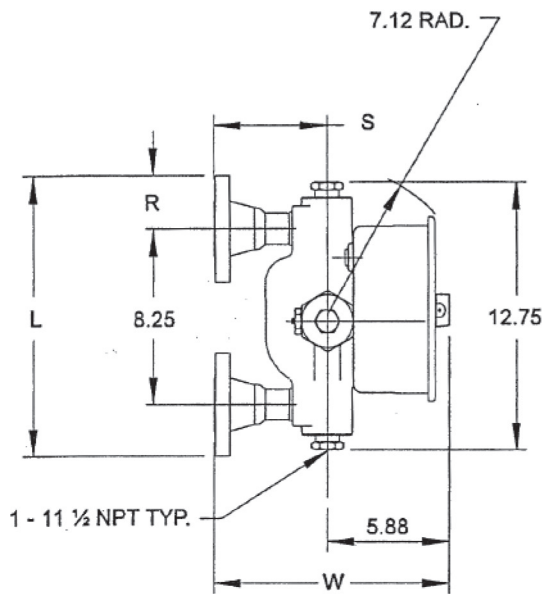
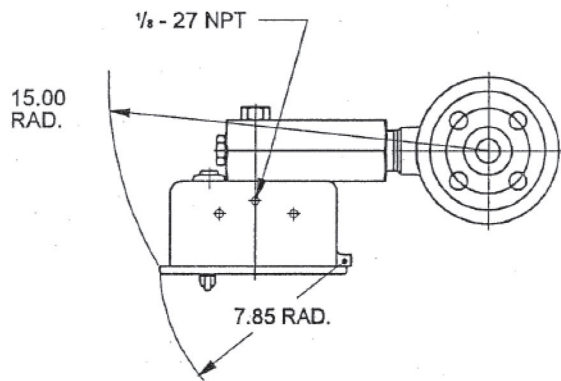
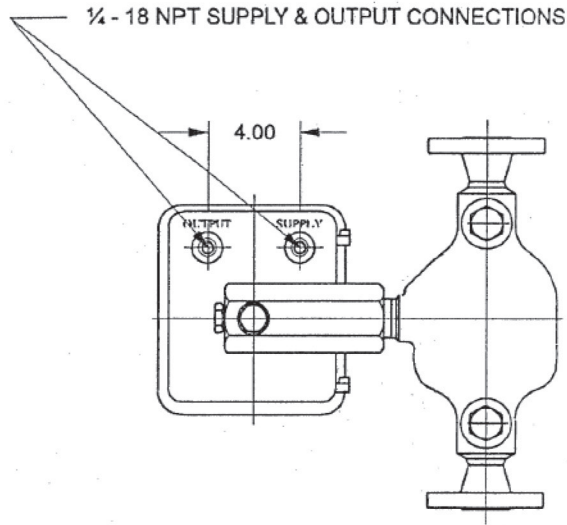

1.00			
ANSI Class		L	S
150	RF		
	RJ		
300	RF		
	RJ		
600	RF		
	RJ		

2.00			
ANSI Class		L	S
150	RF		
	RJ		
150	RF		
	RJ		
150	RF		
	RJ		

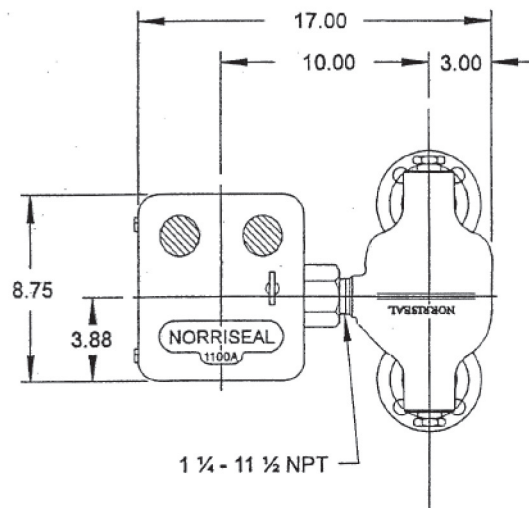

OPERATING AND MAINTENANCE MANUAL

Series 1100A – Liquid Level Switches

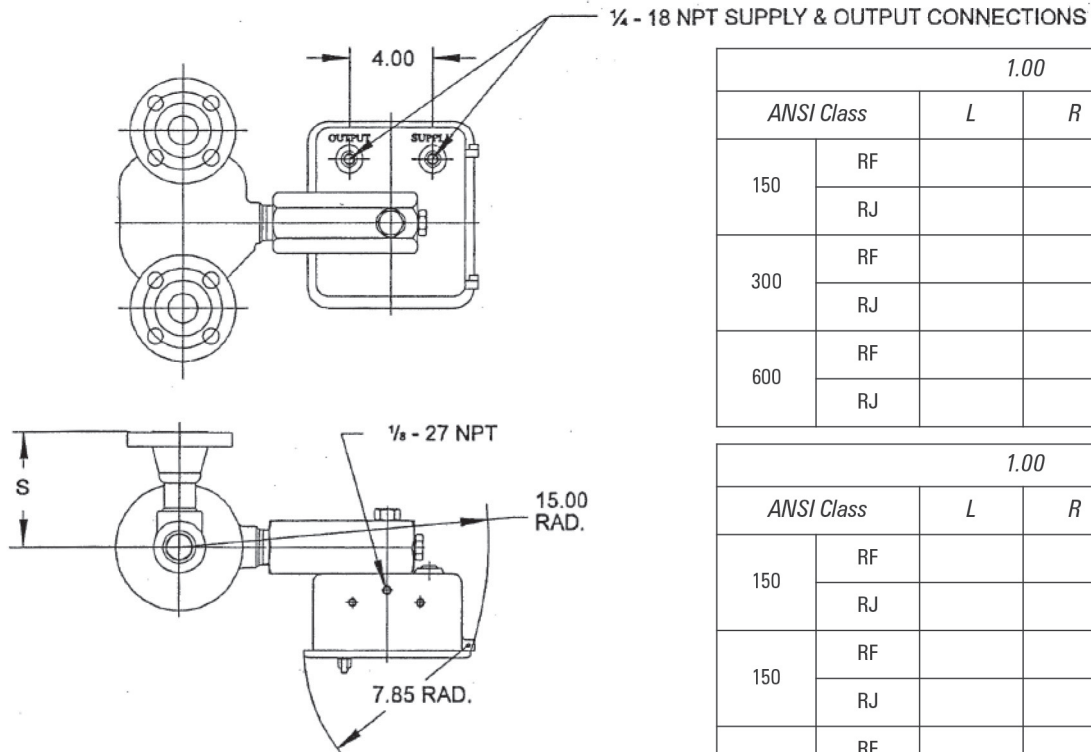

		1.00			
ANSI Class		L	R	S	W
150	RF				
	RJ				
300	RF				
	RJ				
600	RF				
	RJ				

		1.00			
ANSI Class		L	R	S	W
150	RF				
	RJ				
150	RF				
	RJ				
150	RF				
	RJ				

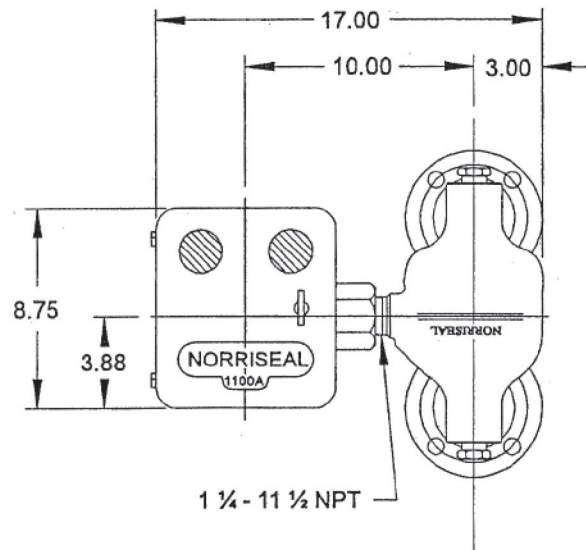
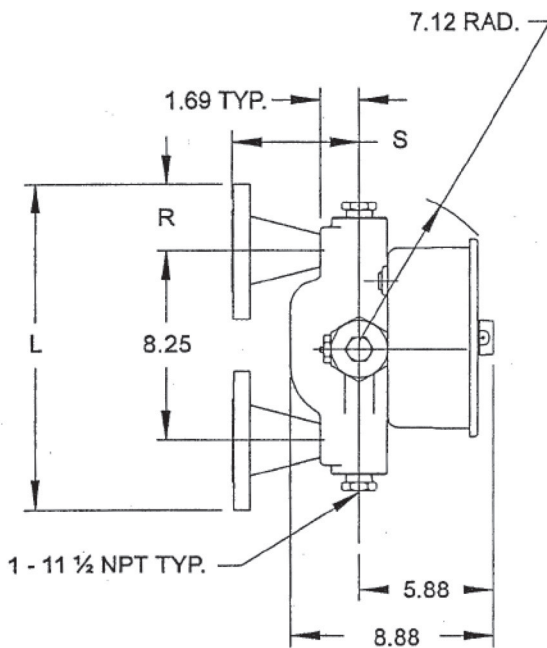

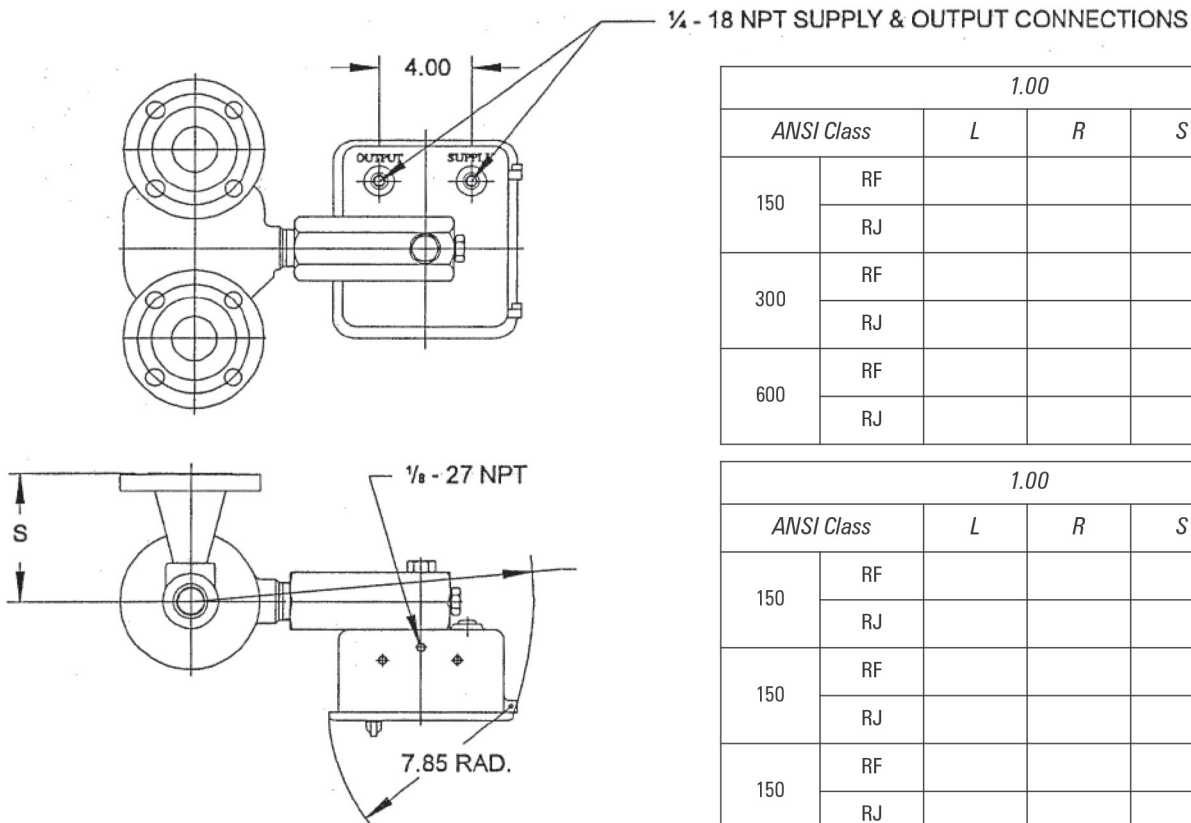

		1.00			
ANSI Class		L	R	S	W
150	RF				
	RJ				
300	RF				
	RJ				
600	RF				
	RJ				

		1.00			
ANSI Class		L	R	S	W
150	RF				
	RJ				
150	RF				
	RJ				
150	RF				
	RJ				

4.0 MAINTENANCE

4.1 Preventive Maintenance

1. In normal service, the O-ring and bearings on the main shaft should last for many years. If a leak does occur, replace the O-rings.
2. If the switch is used in the high paraffin service or interface control, remove and inspect the body of the controller three months after installation and check for debris build up. The frequency of future inspections can be determined by how much debris built up in the first three months.
3. For high temperature service consult your Norriseal Catalog. If you are unsure of the com-

patibility of your fluid with the Norriseal Level Switch, consult your Norriseal Representative

4.2 Basic Electric Switch

1. **NOTICE** – Disconnect the power supply before opening the switch.
2. Remove the cover of the housing, disconnect the lead-in wires, loosen the screws holding the basic switch, and then remove the basic switch.
3. Place the replacement switch in the insulator, insert the screw and place the basic switch in the housing.
4. Tighten the screws and connect the lead-in wires.

5. Be sure the small compression spring is returned to its position between the top of the basic switch and the internal lever.

CAUTION!

To prevent the emission of hot particles, joint surfaces must be thoroughly cleaned before closing the cover.

4.3 TROUBLESHOOTING

Symptom	Probable Cause(s)	Corrective Action(s)
The pilot output pressure gauge indicated an output pressure signal when the fluid level is below the displacer on a direct acting* controller.	<ul style="list-style-type: none"> The spring is too compressed and puts too much pressure on the torque bar. The displacer arm is set too high or the displacer is hitting inside of the chamber. 	<ul style="list-style-type: none"> Back off the spring retainer until the output pressure signal goes off. Recheck it when the fluid rises. Check the displacer arm by moving the leveling bar up and down. If the leveling bar will move in only one direction, this indicates that the displacer arm is riding at either the top or bottom of the vessel connection. By turning the thumb screw the displacer arm can be re-centered in the vessel connection.
The fluid level is above the displacer and the pressure gage indicates no output signal for a direct acting* control.	<ul style="list-style-type: none"> The spring is not compressed enough. The displacer arm is set too low. 	<ul style="list-style-type: none"> Turn the spring retainer which will compress the spring. Turn it until an output signal is indicated by showing pressure on the output pressure gage. Output pressure should go off when the fluid level drops down to the displacer's controllable range. Same as #2 under "corrective action" in the preceding scenario.
The controller does not repeat at the same fluid level after each dump and sometimes fails to either dump or shut off.	<ul style="list-style-type: none"> Paraffin or debris has built up inside of the level control body. 	<ul style="list-style-type: none"> Remove the controller from service and flush out the chamber with a solvent. You can usually tell there is a build-up of paraffin or debris by depressing the torque bar and then releasing it quickly. If the bar does not bounce fast or appears to hardly move, this is a good indication of a build-up of foreign matter in the controller body.
The pneumatic pilot bleeds air continuously.	<ul style="list-style-type: none"> There is foreign matter under the ball in the pilot seat. The snap ring on the snap pilot thrust pin could have slipped down due to some unusual happening. 	<ul style="list-style-type: none"> Remove the pilot from the case and then remove the two cap screws from the bottom of the pilot. Clean the pilot thoroughly and reassemble it. Check the snap's dimension from the bottom of the thrust pin to the bottom of the snap ring. The dimension should be 3/4". If it's not the correct dimension, tap it to the correct measurement.

*WARNING: The output signal will be reversed with the exception of the supply gauge.

OPERATING AND MAINTENANCE MANUAL

Series 1100A – Liquid Level Switches

5.0 PARTS LIST - Standard Service - Pneumatic Pilot

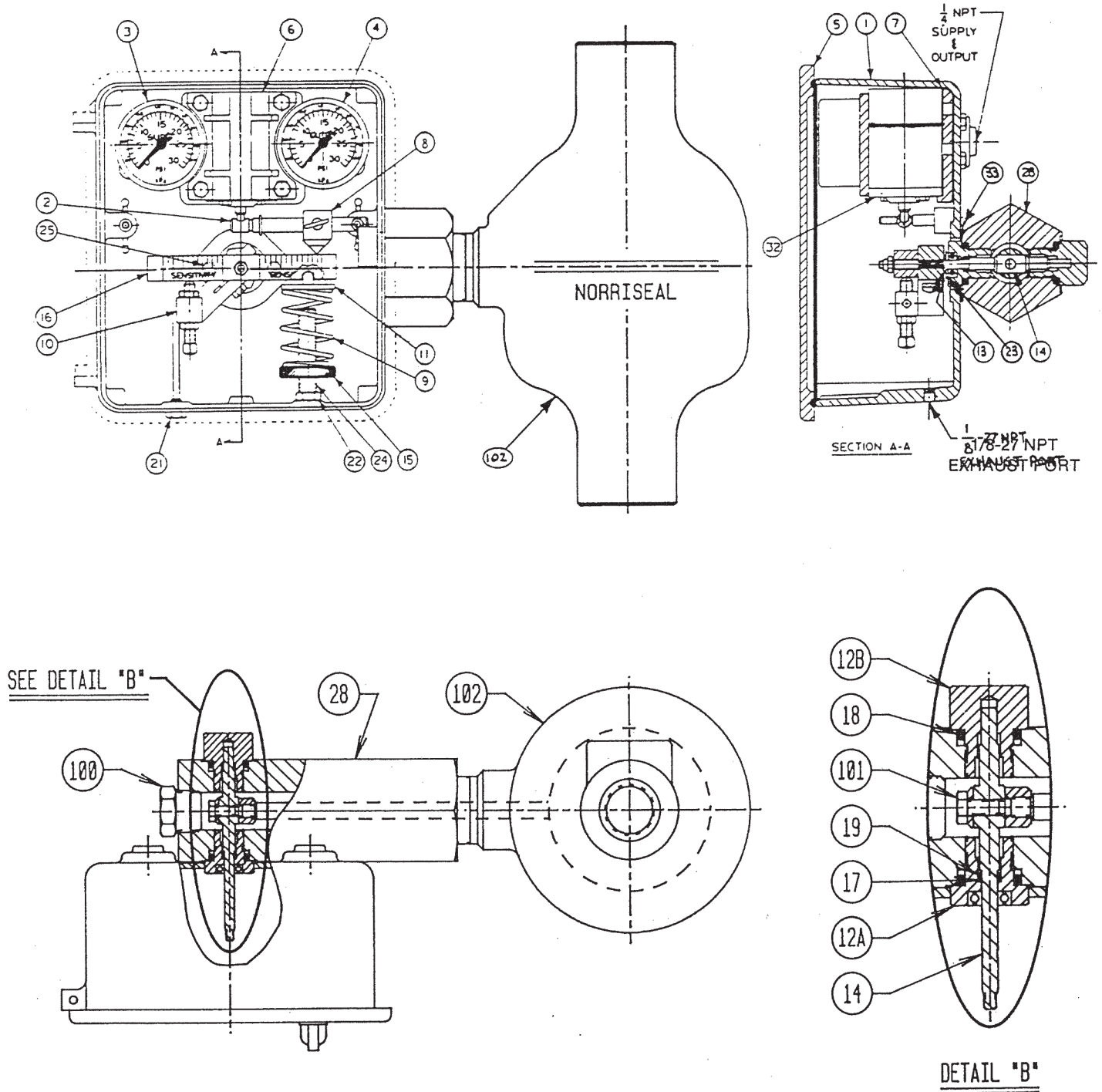

OPERATING AND MAINTENANCE MANUAL

Series 1100A – Liquid Level Switches

Item	Parts Description	Material	Stock No.	Qty.
1	Case Assembly w/Manifold	Aluminum	418907	1
2	Kit Bar Flapper Includes: *Nut Lock 10-32 (1) *Ring Retaining (1) *Bar Flapper (1)	SST SST 303 SST	430504 415053 415794 418700	1
3	Gage Pressure Supply 0-30 PSI	Bronze	415931	1
4	Gage Pressure Output 0-30 PSI	Bronze	415932	1
3&4	Gage Pressure 0-60 PSI	Bronze	416702	2
3&4	Gage Pressure 0-100 PSI	Bronze	416685	2
5	Cover LLS Pneumatic	Aluminum	420155	1
6	Kit Clamp Includes: Screw Cap Hex 1/4-20 x 2 (4) Clamp (1)	SST Aluminum	430503 416591 419714	1
*7	Gasket Manifold/Pilot	Buna-N	415937	1
8	KIT Fulcrum Marine Std. Includes: FULCRUM Sensitivity Marine (1) Screw Thumb 10-32 (1)	Nylon SST	430509 415579 416681	1
			Kit Fulcrum Marine Vib Includes: Fulcrum Sensitivity Marine (1) Nut Hex Reg 10-32 (1) Screw Set Socket 70-32 x .50 (1)	
9	Spring Light Duty (Green) Medium Duty (None) Heavy Duty (Yellow) X-Heavy Duty (Red)	302 SST	415830 415159 415874 416373	1
10	Kit Bar Adj Level Min Includes: Bar Adjusting Level Marine (1) Nut Hex Jam 1/4-28 (2) Screw Cap Hex 1/4-28 x 3/4 (2) Screw Adjusting Level 1/4-28 (1)	Aluminum SST SST SST	432805 411124 415711 416167 416741	1
11	Retainer Spring Upper	Aluminum	419386	1
12	A Block Bearing Inside	303/SST 316/SST	413095 418447	1
	B Block Bearing Outside Capped	303 SST 316 SST	413000 413001	1

Item	Parts Description	Material	Stock No.	Qty.
13	Spacer	303 SST	412763	1
14	Shaft	303 SST	410519	1
		316 SST	411202	
15	Retainer Spring lower	303 SST	411128	1
16	Kit Bar Torque Marine Includes: Bar Torque Marine (1) Nut Lock 10-32 (1) Scale Sensitivity (2)	303 SST SST Vinyl	430507 413592 415053 416184	1
*17	Ring Back-Up 010BU	TFE	415029	2
*18	O-Ring Block Bearing 210	Buna - N Viton** TFE	415111 416013 415452	2
*19	O-Ring Shaft 010	Buna - N Viton** TFE	415103 415855 415449	2
21	Screw Cap Hex 318-24 x 0.50	SST	415939	1
22	Nut Jam Hex 3/8-24	SST	416227	1
23	Washer Flat 0.25	SST	415593	1
24	Stud 3/8-24 x 2.12	SST	416235	1
25	Screw Cap Hex 1/4-28x 0.50 MRN	SST/CTD	412968	2
28	Body LLS 1.25 NPT	1018 CSTL	420156	1
32	Pilot LLS	See Chart 32, Page 22		
33	Gasket Insulator	Phenolic	415827	1
100	Plug Pipe Hex 0.75 NPT	A105/PLTD	425193	1
101	Screw Cap Hex Loc 1/4-20 x 0.50	316 SST	425192	1
102	Chamber Assembly w/Displacer	See Chart 102, Page 23		
*Recommended Spare Parts				
** VITON is Registered at U.S. Patent Office for Dupont's Fluoroelastomers.				
When ordering replacement parts, always specify LLS Serial no.				

OPERATING AND MAINTENANCE MANUAL

Series 1100A – Liquid Level Switches

1100A - Electric Pilot

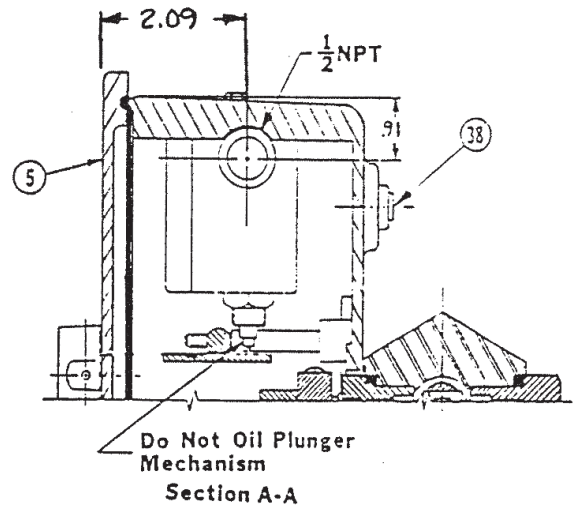
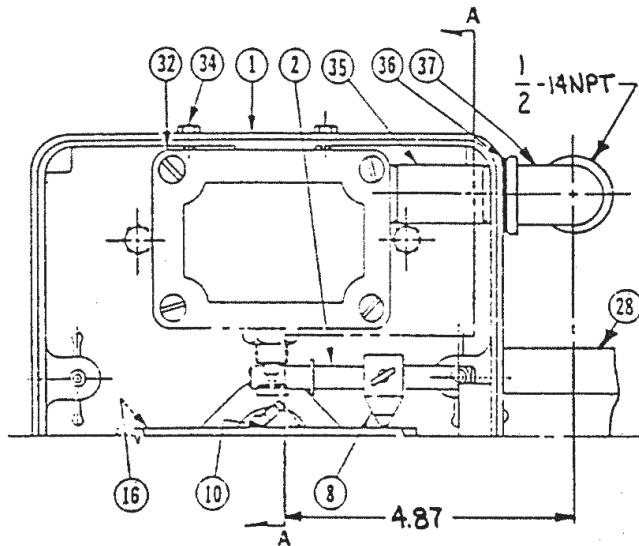

Item No.	Description	Material	Stock No.	Qty. Required
1	Case LLS	Aluminum	419554	1
1	Bar Flapper	303 SST	472840	1
32E	Switch Ex-Proof	DPDT	EXD-Q	1
		SPDT	EX-Q	
		SPDT	OP-Q	
34	SCR CAP HEX 10-32 X 0.38	SST	416213	2
35	Nipple Pipe .50NP X 2.50	CSTL/PLTD	413403	1
*36	O-Ring Size 210	BUNA-N	415111	1
37	Elbow Pipe .50 NPT	M.I./PLTD	411772	1
38	Plug Pipe .25 NPT	Aluminum	416640	2

OPERATING AND MAINTENANCE MANUAL

Series 1100A – Liquid Level Switches

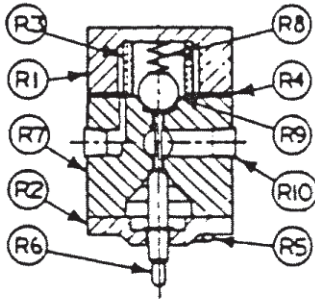

RELIEF PILOT

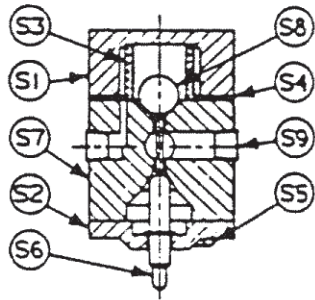

PNEUMATIC PILOT KITS

Pilot Assemblies		Pilot Repair Kits	
Snap	Relief	Snap	Relief
430002	430007	430568	430570

CHART 32 RELIEF

Item No.	Chart 32 R Relief Pilot Relief Pilot Description	Material	Stock No.	Quantity
32R	Kit Pilot Relief Parts Breakdown	See Below	430007	1
R1	Cap Pilot Top	Aluminum	412765	1
R2	Cap Pilot Bottom	Standard	Aluminum	412757
		Vibration	Aluminum/SST	412235
R3	Filter Pilot	Cellulose	416165	1
R4	Gasket Pilot Upper	Buna-N	416163	1
R5	Screw Cap Hex 10-32 x 2.00	SST	416166	2
R6	Pin Thrust w/Snap Ring	SST	410996	1
R7	Body Pilot Relief w/O-Ring	Aluminum/Viton	418975	1
R8	Spring Pilot Relief	SST	416686	1
R9	Ball 0.50	SST	415249	1
R10	Plug Pipe 1/8	Aluminum	415076	2

CHART 32 SNAP

Item No.	Chart 32 R Snap Pilot Snap Pilot Description	Material	Stock No.	Quantity
32S	Kit Pilot Snap Parts Breakdown	See Below	430002	1
S1	Cap Pilot Top	Aluminum	412765	1
S2	Cap Pilot Bottom	Standard	Aluminum	412757
		Vibration	Aluminum/SST	412235
S3	Filter Pilot	Cellulose	416165	1
S4	Gasket Pilot Upper	Buna-N	416163	1
S5	Screw Cap Hex 10-32 x 2.00	SST	416166	2
S6	Pin Thrust w/Snap Ring	SST	410996	1
S7	Body Pilot	Aluminum	412758	1
S8	Ball 0.50	SST	415249	1
S9	Plug Pipe 1/8	Aluminum	415076	2

OPERATING AND MAINTENANCE MANUAL

Series 1100A – Liquid Level Switches

1.00 NPT Process Connections
Left-hand Mount, Pneumatic Pilot

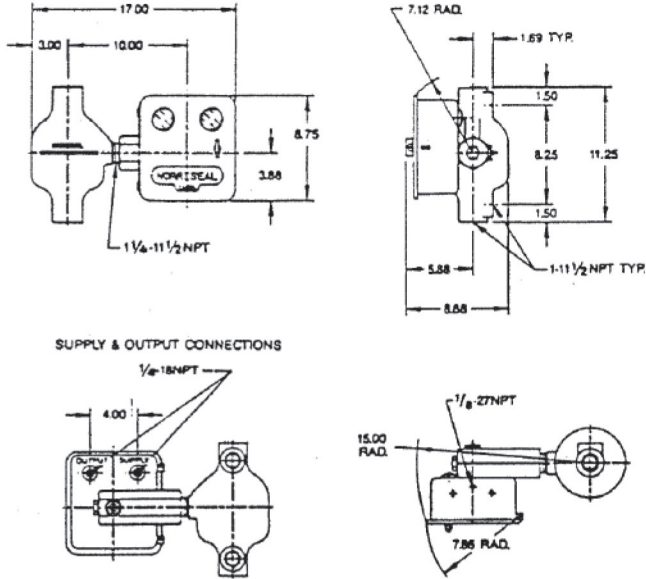

All Dimensions in inches.
All dimensions are applicable for
1.00" Socket Weld and 2.00" Butt Weld

CHART 102 CHAMBER STYLES

Process Connection Size	Process Connection Type	Pressure Rating		Stock Number
		ANSI Class	WP (psi)	
1.00 X 1.00	NPT X NPT	600	1480	420142
1.00 X 1.00	NPT X NPT	900	2220	420663
1.00 X 1.00	NPT X S/W SCH. 80	600	1480	420657
1.00 X 1.00	NPT X S/W SCH. 80	900	2220	420664
1.00 X 2.00	NPT X B/W SCH. 40	600	1480	420658
1.00 X 2.00	NPT X B/W SCH. 80	600	1480	420659
1.00 X 2.00	NPT X B/W SCH. 160	600	1480	420665
1.00 X 2.00	NPT X B/W SCH. 80	900	2220	420157
1.00 X 2.00	NPT X B/W SCH. 160	900	2220	420666
1.00 X 2.00	NPT X RF Flange	600	1480	Request
1.00 X 2.00	NPT X RJ Flange	900	2220	Request
1.00 X 2.00	NPT X RF Flange	600	1480	Request
1.00 X 2.00	NPT X RJ Flange	900	2220	Request

Materials for the Assemblies Listed Above are:

Chamber – ASTM A216

Displacer, Arm & Shaft Clamp – SST

Note: For Other Chamber Materials, Consult Factory

Flanged

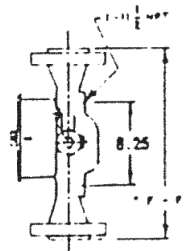

1.00		
ANSI Class	"F – F"	
150	RF	15.00
	RJ	15.19
300	RF	15.50
	RJ	15.69
600	RF	16.00
	RJ	16.19
2.00		
ANSI Class	"F – F"	
150	RF	16.38
	RJ	16.75
300	RF	16.88
	RJ	17.38
600	RF	17.62
	RJ	17.75

HEADQUARTERS, MANUFACTURING PLANT AND SALES



www.norriseal.com

11122 West Little York • Houston, Texas 77041

T: (713)466-3552 • F: (713)896-7386

*Due to the continuous improvement at Norriseal,
specifications and/or prices are subject
to change without notice or obligation.*