

Block & Bleed



Introduction

Sesto Valves specializes in custom designed ball valve solutions for the chemical, petrochemical and energy industries. Applications include cryogenics, extreme high temperatures, metal seated applications, as well as specialty double block and bleed emergency shutdown valve solutions. Headquartered in Agrate Brianza (MB) Italy, we are a premium ball valve manufacturer with over 30+ years of engineering experience. Our valves are 100% designed, manufactured, and tested in Italy with complete control of product quality and material traceability. We source only the best materials from local and global partners to ensure quality and competitive pricing.

Our philosophy is to make valves that fit your application, not the other way around. We match materials and trims to maximize performance and reliability, with ready access to special coatings and exotic or super alloys. Our engineers design valves to optimize fit and function, including special face-to-face, multiport or combination valves for cost and space savings. Our quality team inspects every component and runs extensive performance tests for design verification and production phases, and can also include your own customer specified testing. In order to provide a more complete solution, we partner directly with key valve automation industry leaders to provide actuation and automation controls in a comprehensive valve package. Contact Sesto Valves today with your most difficult valve application and we'll give you our best resources and expertise to help you reach your goals.

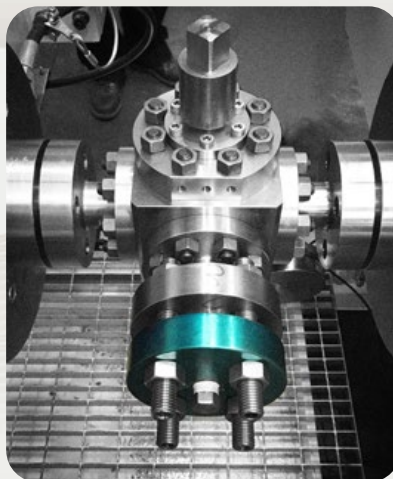
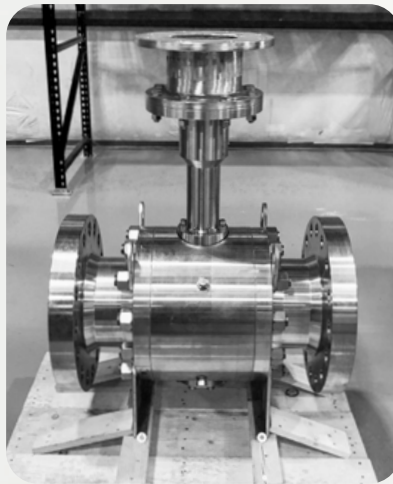

Europe
World Headquarters
Sesto SG, Italy
Via Socrate, 10
20864 Agrate Brianza (MB)
Italy
Tel: +39.039.902.0888
Fax: +39.039.902.0889



North America
Wentzville, Missouri
114 Resource Drive
Wentzville, MO 63385
United States
Tel: +1.636.856.8576
Fax: +1.636.856.8930

Features and Benefits

- Class 150 to Class 2500
- Size Range ¼" thru 16" (Class Dependent)
- Single and Double Isolation, Multi-Port Designs Available
- Floating and Trunnion, Full and Reduced Bore
- Bolted Body Facilitates Inline Maintenance
- Venting/Relief Designs in Multiple Configurations
- End Connections: RF, RTJ, BW, SW, NPT, BSP, Special
- Fugitive Emissions ISO 15848
- Fire-Safe Tested API 607
- Anti-Static Device and Live-Loaded Packing
- Guided Seat Design on Trunnion Design
- Blowout Proof, Low Torque Guided Stem Design
- Wide Range of Soft and Metal Seated Options
- Manual, Electric, or Pneumatic Operators Available
- Custom Face-to-Face Lengths Available

Certifications and Compliance

Sesto Valves are designed and manufactured to internationally recognized standards including but not limited to the following:

- Design:** API 6D, API 608
- Fire Testing:** API 607, API 6FA, BS 6755 Part II
- Testing:** API 6A, API 598, API 17D, ISO 5208, BS 6755 Part I
- Marking:** API 6A, MSS-SP-25, PED
- Certifications:** API607, SIL, NACE, MR0175, PED, Fugitive Emissions

Partial List of Applications

- Oil & Gas Pipelines
- Refineries and Petrochemical Plants
- Power Generation
- Gas and Coal Fired Turbines
- Gas Purge Credit Systems
- Floating Production Storage & Offloading
- Offshore Platforms
- Emergency Shut Down Valves
- Chemical Injection
- Gas Measurement Systems

Versatility & Reliability

The Sesto Valves double block and bleed design is engineered for critical service and can be customized for nearly any application. Integrating two ball valves into one body achieves double block and double isolation (API 6D & OSHA compliant) while minimizing leak paths and reducing footprint. Multiple valves can potentially be replaced with a single unit that can include one or more bleed valves configured to specific requirements. Both ball valves can be operated independently with manual or powered operators, and available safety lockouts. Additionally, the design allows for integrity check of seals when fail-proof isolation is critical and leakage could have catastrophic consequences. Sesto Valves DBB solutions are made to simplify piping requirements while increasing safety and reliability.

End Connections

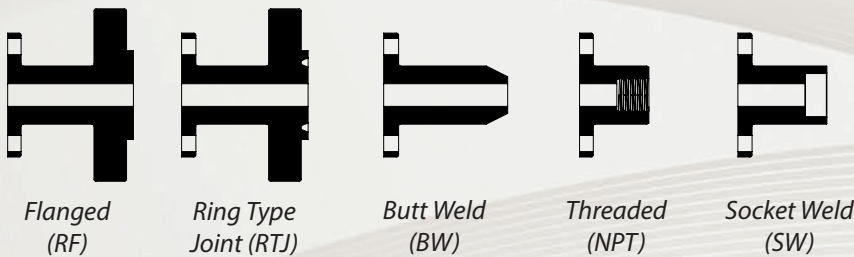

Why Sesto?

Sesto Double Block & Bleed Design	The Sesto Difference
Precision Machined Forged Body	The forged body eliminates the possibility of leakage due to poor castings. Precision finish machining keeps tight tolerances to ensure secure assembly for high pressure, critical applications.
Ball/Seat Lapping	Lapping seats to the ball ensures tight tolerances, improving shut-off sealing capability while lowering torque requirements.
Application Specific Testing Protocol	We build upon proven API 598, API 6D, and MSS-SP-61 testing standards and customize our testing protocols to simulate actual service pressure conditions, guaranteeing valve performance before field installation.
Customizable Design	The design is highly customizable so end connections, face-to-face lengths, and other features can be modified to suit application requirements.
Reliable, Redundant Critical Shutdown Valves	Where valve reliability is critical to operation the Sesto

Block & Bleed Design

- True double block & bleed isolation
- Two isolation valves in one body and one or more vent valves
- Achieve more functions in a compact package
- Reduction of leak paths increases safety, and reduces emissions
- Full port allows for minimal pressure drop
- Integrated forged body with high grade materials
- Floating or trunnion-mounted ball designs
- Field repairable design
- Manual or Automated operation with safety lockout

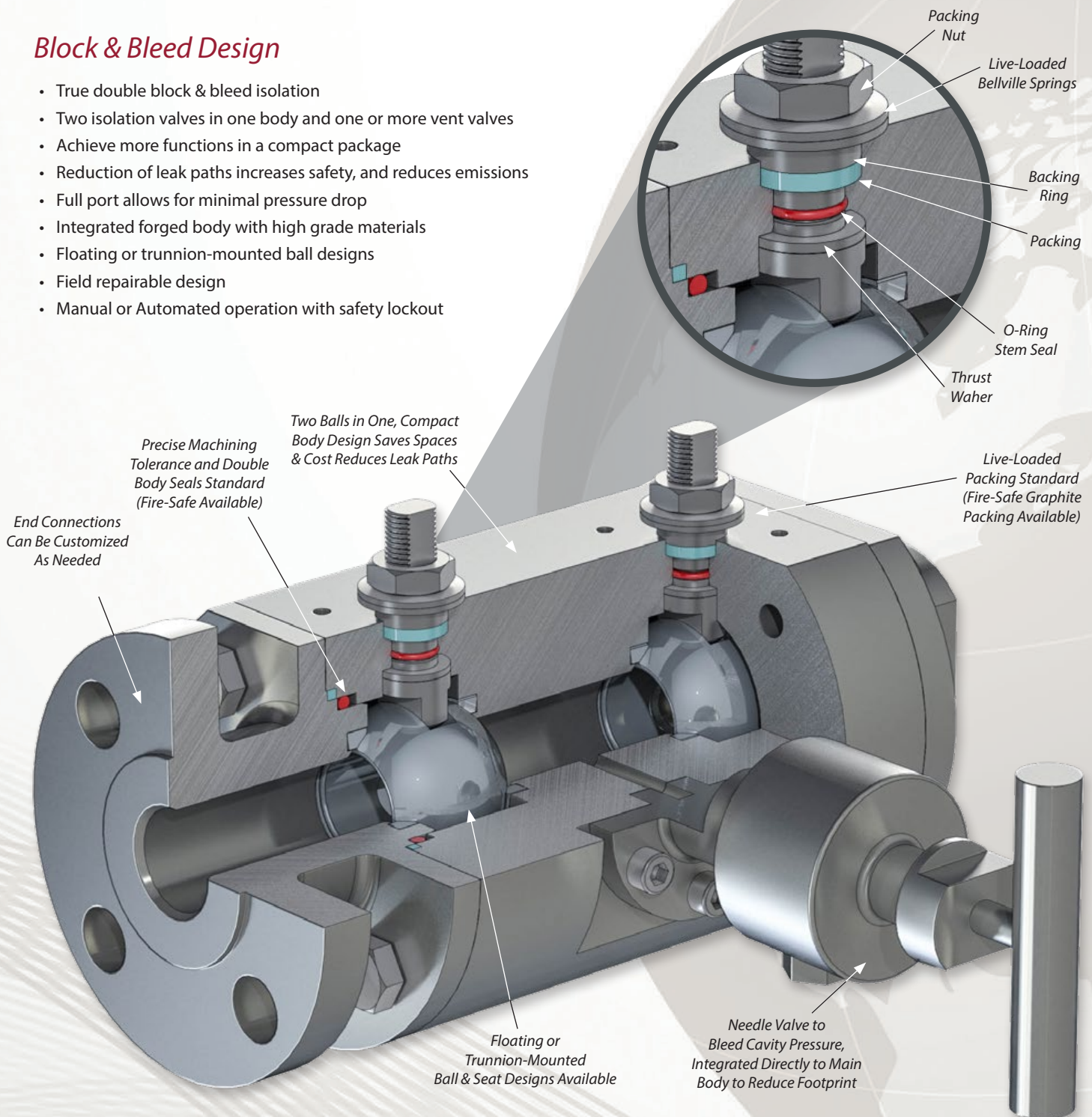

Application Specific Testing Protocol

To test the efficacy of the double block and bleed ball valve design and performance, Sesto Valves has developed detailed testing protocols that go above and beyond current industry practice. Standard production tests do not always accurately simulate the conditions for the varying scenarios of real world double block and bleed valve applications. With the API 598, API 6D, and MSS-SP-61 standards as the foundation, Sesto Valves builds upon this to customize multiport testing protocol according to an understanding of specific application requirements. Sesto Valves believes that using proven testing standards and applying them in the context of actual service conditions is the best way to accurately test double block and bleed valves.



Ball/Seat Lapping

Lapped ball and seat sets are utilized when materials and sealing requirements dictate. This precise manufacturing process ensures the lowest operating torque and the tightest possible sealing capability of the ball and seats, while at the same time providing for an exceptionally long service life for the intended application. Lapping is a surface finishing process where extremely fine polishing compounds are used as the lapping agent to achieve remarkably close mating surfaces.



Customizable Design

Sesto Valves DBB design is highly customizable, available with up to five (5) valves integrated into a single unit. Custom end connections, face-to-face lengths, and a wide range to seat options can be selected and optimized to suit application requirements.

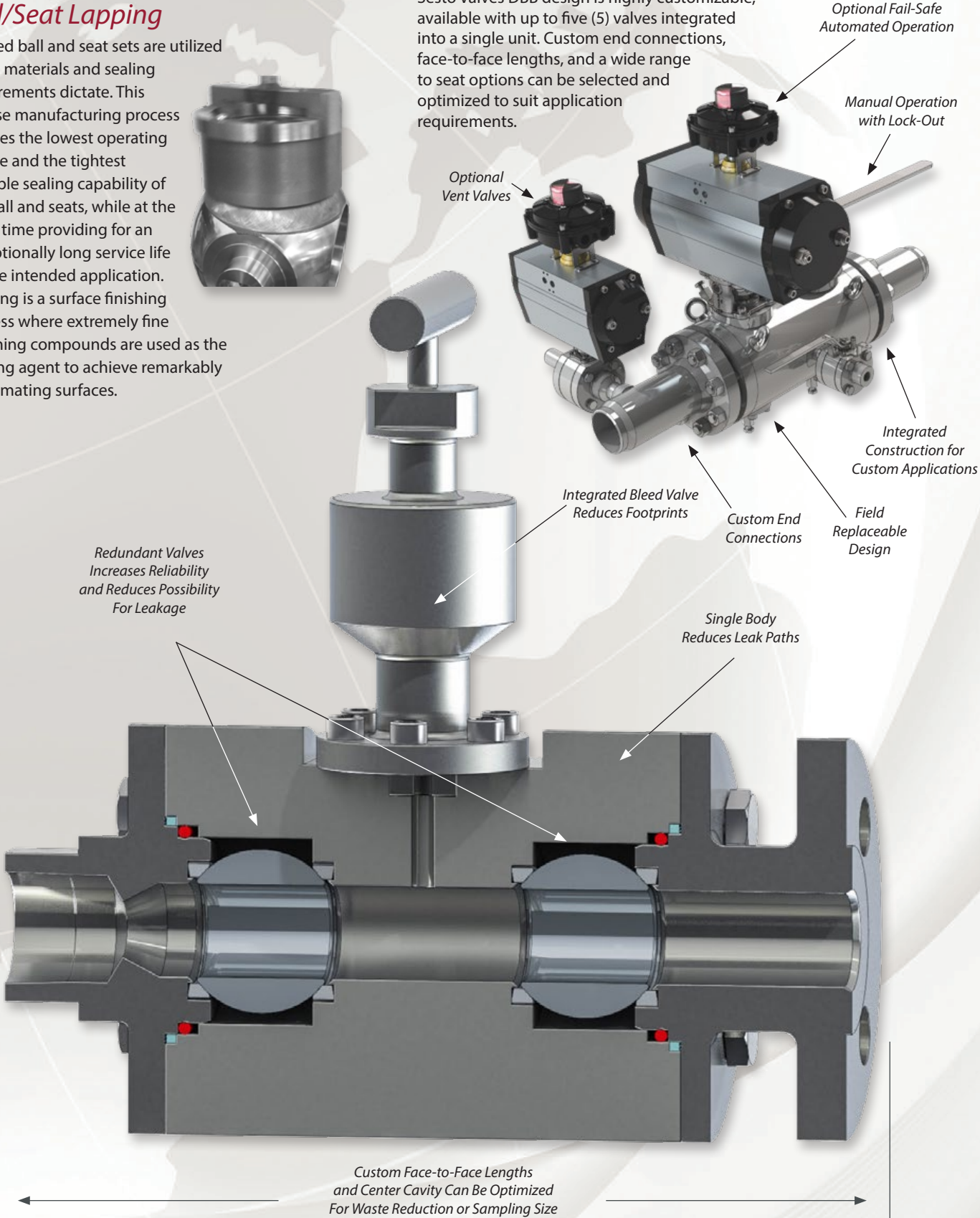

*Redundant Valves
Increases Reliability
and Reduces Possibility
For Leakage*

*Optional Fail-Safe
Automated Operation*

*Manual Operation
with Lock-Out*

*Optional
Vent Valves*

*Integrated Bleed Valve
Reduces Footprints*

*Custom End
Connections*

*Integrated
Construction for
Custom Applications*

*Field
Replaceable
Design*

*Single Body
Reduces Leak Paths*

*Custom Face-to-Face Lengths
and Center Cavity Can Be Optimized
For Waste Reduction or Sampling Size*



Worldwide Headquarters
Via Socrate, 10, 20864 Agrate Brianza (MB) Italy
Tel: +39.039.902.0888 | Fax: +39.039.902.0889

North American Headquarters
114 Resource Drive Wentzville, MO 63385 USA
Tel: +1.636.856.8576 Fax: +1.636.856.8930

Web: www.sestovalves.com | Email: sales@sestovalves.com

Rev: Jan. 26, 2022