



**DUCTILE IRON 050/051 SERIES
STAINLESS STEEL 650/651 SERIES
BUTTERFLY VALVES**
2" - 24" 200/150 PSI Bi-Directional Service, Up to 48" Available



Certifications & Warranty Details & Definitions



CE Marking

is a mandatory conformity marking for certain products sold within the European Economic Area (EEA) since 1985. The CE marking is also found on products sold outside the EEA that are manufactured in, or designed to be sold in, the EEA. This makes the CE marking recognizable worldwide even to people who are not familiar with the European Economic Area. It is in that sense similar to the FCC Declaration of Conformity used on certain electronic devices sold in the United States.

The CE marking is the manufacturer's declaration that the product meets the requirements of the applicable EC directives.



NSF/ANSI 61

NSF/ANSI Standard 61

NSF/ANSI 61 sets health effects criteria for many water system components including:

- Protective barrier materials (cements, paints, coatings)
- Joining and sealing materials (gaskets, adhesives, lubricants)
- Mechanical devices (water meters, valves, filters)
- Pipes and related products (pipe, hose, fittings)
- Plumbing devices (faucets, drinking fountains)
- Process media (filter media, ion exchange resins)
- Non-metallic potable water materials

As it relates to valves specifically, it assures that the materials in contact with the flow stream do not introduce toxins into the water in amounts that exceed allowable exposure limits. Some trims excluded. See pg. 4-5



NSF/ANSI 372

NSF/ANSI 372

is essentially equivalent to Annex G of NSF/ANSI Standard 61 and assures that the materials used in the water contact components of a water system component do not exceed 0.25% lead content. Some trims excluded. See pg. 4-5



ABS, the American Bureau of Shipping

offers several different reviews which reduce the amount of analysis required for the use of a product in a specific application related to ABS class vessels. An ABS Product Design Assessment (PDA) is the assessment of a product for use on a variety of ABS-classed ships following a technical evaluation. The PDA reduces the turnaround time for approval on a specific ship. When a specific ship is chosen, ABS technical staff verifies that the product is suitable for use after a review of the PDA. On an even higher level of approval, achieving ABS Type Approval for a product grants that the product can be selected by ship designers, builders and owners to be placed aboard an ABS-classed vessel.



USCG / Coast Guard:

Valves designed for use in ship engineering systems must comply with USCG requirements according to industry standards specified in Title 46, Code of Federal Regulations, Part 56 (46 CFR Part 56). Some applications such as pressure-vacuum relief valves for tank vessels or liquefied compressed gas safety relief valves do require additional USCG Type Approval, and must conform to requirements outlined in 46 CFR Part 162, sections 162.017 and 162.018. For equipment or materials to receive USCG Type Approval, they must be demonstrated to comply with the relevant requirements in the regulations, successfully complete the specified tests, and be enrolled in a quality control or follow up program as required.



ISO 5211:

This standard defines a standardized interface system between industrial valves and the part turn actuators used to operate them. It details the dimensional requirements for both the mounting flanges on both devices as well as the driving and driven components. This standardization simplifies the design of or eliminates the need for interface components between part turn valves and actuators.



The Canadian Registration Number (CRN)

is a number issued by each province or territory of Canada to the design of a boiler, pressure vessel or fitting. The CRN identifies the design has been accepted and registered for use in that province or territory.

3-Year Limited Warranty

Delta T Products, LLC, hereinafter referred to as "DTP", provides the following limited 3 year manufacturer's warranty regarding all quarter turn valve products manufactured by DTP. This warranty includes all valves which are manufactured by DTP and only applies to those items which are clearly identified as Delta T brand labeled products. The warranty stated herein is expressly in lieu of all other warranties and representations, expressed or implied, or statutory, including, without limitation, the implied warranty of fitness for a particular purpose.

DTP warrants its products to be free from defects in materials and workmanship when these products are used for the purpose for which they were designed and manufactured. DTP does not warrant its products against chemical or stress corrosion or against any other failure other than from defects in materials or workmanship. The warranty period is for thirty-six months from the delivery date by DTP to its customers. Any claims regarding this warranty must be in writing and received by DTP before the last effective date of the warranty period.

Upon receipt of a warranty claim, DTP reserves the right to inspect the product(s) in question at either the field location or at a DTP designated facility. If, after the inspection of the product(s) in question, DTP determines that the purchaser's claim is covered by this warranty, DTP's sole liability and the purchaser's sole remedy under this warranty is limited to the refunding of the purchase price or repair or replacement thereof, at the sole discretion of DTP.

DTP will not be liable for any repairs, labor, material, or other expenses that are not specifically authorized in writing by DTP, and in no event shall DTP be liable for any direct or consequential damages arising out of any defect from any cause whatsoever. If any DTP products are modified or altered in any way, without the expressed written consent of DTP, the products will not be covered by this warranty.

DTP shall not be liable for any incidental, consequential or other damages, costs, or economic losses, including, without limitation, any resulting from labor charges, delays, vandalism, negligence, fouling caused by foreign material damage from adverse flow conditions, chemicals, or acts of God, or circumstances that are not controllable or reasonably foreseeable by DTP.

This warranty shall be invalidated in all circumstances where DTP, acting reasonably, determines that the product(s) was subject to abuse, misuse, neglect, or improper application, installation, alteration or modification not authorized in writing by DTP. All claims received by DTP beyond the warranty period are invalid and shall not be accepted.

Except for the express written warranty contained herein, DTP does not make any other warranty, condition, guarantee, or indemnity, express or implied, statutory or otherwise, regarding the products including without limitation, to the extent permitted by law, any warranty or merchantability or fitness for a particular purpose. All other warranties, conditions, guarantees and indemnities regarding any products are hereby disclaimed, excluded and overwritten.

Contents



*Ordering Guidelines
& Trim Codes*

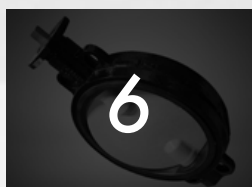

*050/051 Butterfly Valves
Ductile Iron Body Lug & Wafer Style*



*650/651 Butterfly Valves
Stainless Steel Body Lug & Wafer Style*



*Seat & Disc Guide
Options & Material Selection*



*Chemical Compatibility
& Crossover Guide*

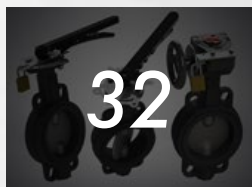

*Handles, Gear Operators,
& Lockout Devices*



Installation Guidelines

050/051 & 650/651 Butterfly Valves

Ordering Guidelines & Trim Codes

Ordering Guideline

Size	Series	Trim	Operator
<input type="text"/>	<input type="text"/>	<input type="text"/>	<input type="text"/>
015 = 1.5" (050/051 Only) 020 = 2" 025 = 2.5" 030 = 3" 040 = 4" 050 = 5" 060 = 6" 080 = 8" 100 = 10" 120 = 12" 140 = 14" 160 = 16" 180 = 18" 200 = 20" 240 = 24"	050 = Wafer Ductile Iron 051 = Lug Ductile Iron 650 = Wafer CF8M 651 = Lug CF8M	See Chart Below 	BST = Bare Stem HND = Lever Handle GOP = Manual Gear Operator ILP = Lever Handle w/ Infinite Locking Plate

Trim Codes	Body	Disc	Stem	Seat	NSF61	NSF372	Max Pressure	Temperature Range	
261	DI	DI-NP	416	NR	NO	YES	200 PSI	-55°F to 210°F	-48°C to 99°C
262	DI	DI-NP	416	EPDM	NO	YES	200 PSI	-40°F to 275°F	-40°C to 135°C
263	DI	DI-NP	416	BUNA	NO	YES	200 PSI	10°F to 180°F	-12°C to 82°C
264	DI	DI-NP	416	VITON	NO	YES	200 PSI	0°F to 392°F	-18°C to 200°C
265	DI	DI-NP	416	BEF	NO	YES	200 PSI	-40°F to 230°F	-40°C to 110°C
266	DI	DI-NP	416	WEF	NO	YES	200 PSI	-40°F to 230°F	-40°C to 110°C
267	DI	DI-NP	416	HT-EPDM	NO	YES	200 PSI	-4°F to 302°F	-20°C to 150°C
268	DI	DI-NP	416	WR-EPDM	NO	YES	200 PSI	14°F to 250°F	-10°C to 121°C
269	DI	DI-NP	416	HNBR	NO	YES	200 PSI	-30°F to 330°F	-34°C to 166°C
270	DI	DI-NP	416	SIL	NO	YES	200 PSI	-40°F to 400°F	-40°C to 204°C
360	DI/CF8M	PTFE/SS	416/431	BEF	YES	YES	200 PSI	-40°F to 230°F	-40°C to 110°C
361	DI/CF8M	PTFE/SS	316/316	BEF	YES	YES	200 PSI	-40°F to 230°F	-40°C to 110°C
371	DI	CF8M	316	BEF	YES	YES	200 PSI	-40°F to 230°F	-40°C to 110°C
380	DI/CF8M	POL CF8M	416/431	BEF	YES	YES	200 PSI	-40°F to 230°F	-40°C to 110°C
381	DI/CF8M	POL CF8M	316/316	BEF	YES	YES	200 PSI	-40°F to 230°F	-40°C to 110°C
455	DI	CF8M	316	PTFE/V	YES	YES	150 PSI	-4°F to 250°F	-20°C to 121°C
457	DI/CF8M	PTFE/SS	316/316	PTFE/V	YES	YES	150 PSI	-4°F to 250°F	-20°C to 121°C
461	DI/CF8M	PTFE/SS	316/316	VITON	NO	YES	200 PSI	0°F to 392°F	-18°C to 200°C
462	DI/CF8M	PTFE/SS	316/316	PTFE/E	YES	YES	150 PSI	-4°F to 250°F	-20°C to 121°C
463	DI/CF8M	PTFE/SS	416/431	PTFE/E	YES	YES	150 PSI	-4°F to 250°F	-20°C to 121°C
464	DI/CF8M	PTFE/SS	416/431	VITON	NO	YES	200 PSI	0°F to 392°F	-18°C to 200°C
465	CF8M	POL CF8M	431	BUNA	YES	YES	200 PSI	10°F to 180°F	-12°C to 82°C
466	CF8M	POL CF8M	316	BUNA	YES	YES	200 PSI	10°F to 180°F	-12°C to 82°C
479	CF8M	POL CF8M	431	EPDM	YES	YES	200 PSI	-40°F to 275°F	-40°C to 135°C
480	CF8M	POL CF8M	316	EPDM	YES	YES	200 PSI	-40°F to 275°F	-40°C to 135°C
482	DI/CF8M	CF8M	416/431	PTFE/E	YES	YES	150 PSI	-4°F to 250°F	-20°C to 121°C
482P	DI/CF8M	POL CF8M	416/431	PTFE/E	YES	YES	150 PSI	-4°F to 250°F	-20°C to 121°C
483	DI/CF8M	CF8M	316/316	PTFE/E	YES	YES	150 PSI	-4°F to 250°F	-20°C to 121°C
483P	DI/CF8M	POL CF8M	316/316	PTFE/E	YES	YES	150 PSI	-4°F to 250°F	-20°C to 121°C
492	CF8M	POL CF8M	431	VITON	NO	YES	200 PSI	0°F to 392°F	-18°C to 200°C
493	CF8M	POL CF8M	316	VITON	NO	YES	200 PSI	0°F to 392°F	-18°C to 200°C

Trim Codes	Body	Disc	Stem	Seat	Max Pressure	NSF61	NSF372	Temperature Range
516	DI	CF8M	416	NR	200 PSI	YES	YES	-55°F to 210°F -48°C to 99°C
517	DI	CF8M	316	NR	200 PSI	YES	YES	-55°F to 210°F -48°C to 99°C
518	DI	CF8M	416	SIL	200 PSI	YES	YES	-40°F to 400°F -40°C to 204°C
519	DI	CF8M	316	SIL	200 PSI	YES	YES	-40°F to 400°F -40°C to 204°C
520	DI	CF8M	316	WEF	200 PSI	YES	YES	-40°F to 230°F -40°C to 110°C
579	DI	CF8M	416	EPDM	200 PSI	YES	YES	-40°F to 275°F -40°C to 135°C
580	DI	CF8M	316	EDPM	200 PSI	YES	YES	-40°F to 275°F -40°C to 135°C
582	DI	CF8M	416	BUNA	200 PSI	YES	YES	10°F to 180°F -12°C to 82°C
583	DI	CF8M	316	BUNA	200 PSI	YES	YES	10°F to 180°F -12°C to 82°C
585	DI	CF8M	416	BEF	200 PSI	YES	YES	-40°F to 230°F -40°C to 110°C
586	DI	CF8M	316	BEF	200 PSI	YES	YES	-40°F to 230°F -40°C to 110°C
587	DI	CF8M	316	WBUNA	200 PSI	YES	YES	-30°F to 230°F -34°C to 110°C
588	DI	CF8M	416	WBUNA	200 PSI	YES	YES	-30°F to 230°F -34°C to 110°C
589	DI	CF8M	416	WEF	200 PSI	YES	YES	-40°F to 230°F -40°C to 110°C
590	DI	CF8M	416	HT-EPDM	200 PSI	YES	YES	-4°F to 302°F -20°C to 150°C
591	DI	CF8M	316	HT-EPDM	200 PSI	YES	YES	-4°F to 302°F -20°C to 150°C
592	DI	CF8M	416	WR-EPDM	200 PSI	YES	YES	14°F to 250°F -10°C to 121°C
593	DI	CF8M	316	WR-EPDM	200 PSI	YES	YES	14°F to 250°F -10°C to 121°C
594	DI	CF8M	416	HNBR	200 PSI	YES	YES	-30°F to 330°F -34°C to 166°C
595	DI	CF8M	316	HNBR	200 PSI	YES	YES	-30°F to 330°F -34°C to 166°C
720	DI	AL-BZ	316	BEF	200 PSI	YES	YES	-40°F to 230°F -40°C to 110°C
780	DI	AL-BZ	416	EPDM	200 PSI	YES	YES	-40°F to 275°F -40°C to 135°C
781	DI	AL-BZ	316	EPDM	200 PSI	YES	YES	-40°F to 275°F -40°C to 135°C
782	DI	AL-BZ	316	BUNA	200 PSI	YES	YES	10°F to 180°F -12°C to 82°C
783	DI	AL-BZ	416	BUNA	200 PSI	YES	YES	10°F to 180°F -12°C to 82°C
784	DI	AL-BZ	416	BEF	200 PSI	YES	YES	-40°F to 230°F -40°C to 110°C
785	DI	AL-BZ	416	WEF	200 PSI	YES	YES	-40°F to 230°F -40°C to 110°C
786	DI	AL-BZ	316	WEF	200 PSI	YES	YES	-40°F to 230°F -40°C to 110°C
788	DI	AL-BZ	416	VITON	200 PSI	NO	YES	0°F to 392°F -18°C to 200°C
789	DI	AL-BZ	316	VITON	200 PSI	NO	YES	0°F to 392°F -18°C to 200°C
790	DI	AL-BZ	416	HT-EPDM	200 PSI	YES	YES	-4°F to 302°F -20°C to 150°C
791	DI	AL-BZ	316	HT-EPDM	200 PSI	YES	YES	-4°F to 302°F -20°C to 150°C
792	DI	AL-BZ	416	WR-EPDM	200 PSI	YES	YES	14°F to 250°F -10°C to 121°C
793	DI	AL-BZ	316	WR-EPDM	200 PSI	YES	YES	14°F to 250°F -10°C to 121°C
794	DI	AL-BZ	416	HNBR	200 PSI	YES	YES	-30°F to 330°F -34°C to 166°C
795	DI	AL-BZ	316	HNBR	200 PSI	YES	YES	-30°F to 330°F -34°C to 166°C
796	DI	AL-BZ	416	NR	200 PSI	YES	YES	-55°F to 210°F -48°C to 99°C
797	DI	AL-BZ	316	NR	200 PSI	YES	YES	-55°F to 210°F -48°C to 99°C
798	DI	AL-BZ	416	SIL	200 PSI	YES	YES	-40°F to 400°F -40°C to 204°C
799	DI	AL-BZ	316	SIL	200 PSI	YES	YES	-40°F to 400°F -40°C to 204°C
897	DI	NY11	416	EPDM	200 PSI	YES	YES	-40°F to 275°F -40°C to 135°C
898	DI	NY11	416	BUNA	200 PSI	YES	YES	10°F to 180°F -12°C to 82°C
899	DI	NY11	416	VITON	200 PSI	NO	YES	0°F to 392°F -18°C to 200°C
900	DI	NY11	416	BEF	200 PSI	YES	YES	-40°F to 230°F -40°C to 110°C
901	DI	NY11	416	WEF	200 PSI	YES	YES	-40°F to 230°F -40°C to 110°C
930	DI/CF8M	PTFE/SS	416/431	WEF	200 PSI	YES	YES	-40°F to 230°F -40°C to 110°C
931	DI/CF8M	PTFE/SS	316/316	WEF	200 PSI	YES	YES	-40°F to 230°F -40°C to 110°C
940	DI/CF8M	CF8M	416/431	WEF	200 PSI	YES	YES	-40°F to 230°F -40°C to 110°C
941	DI/CF8M	CF8M	316/316	WEF	200 PSI	YES	YES	-40°F to 230°F -40°C to 110°C
950	CF8M	POL CF8M	416	WEF	200 PSI	YES	YES	-40°F to 230°F -40°C to 110°C
951	CF8M	POL CF8M	316	WEF	200 PSI	YES	YES	-40°F to 230°F -40°C to 110°C
962	DI	CF8M	416	VITON	200 PSI	NO	YES	0°F to 392°F -18°C to 200°C
963	DI	CF8M	316	VITON	200 PSI	NO	YES	0°F to 392°F -18°C to 200°C

050/051 Butterfly Valves

Features & Benefits

Ductile Iron Body - Lug & Wafer Styles

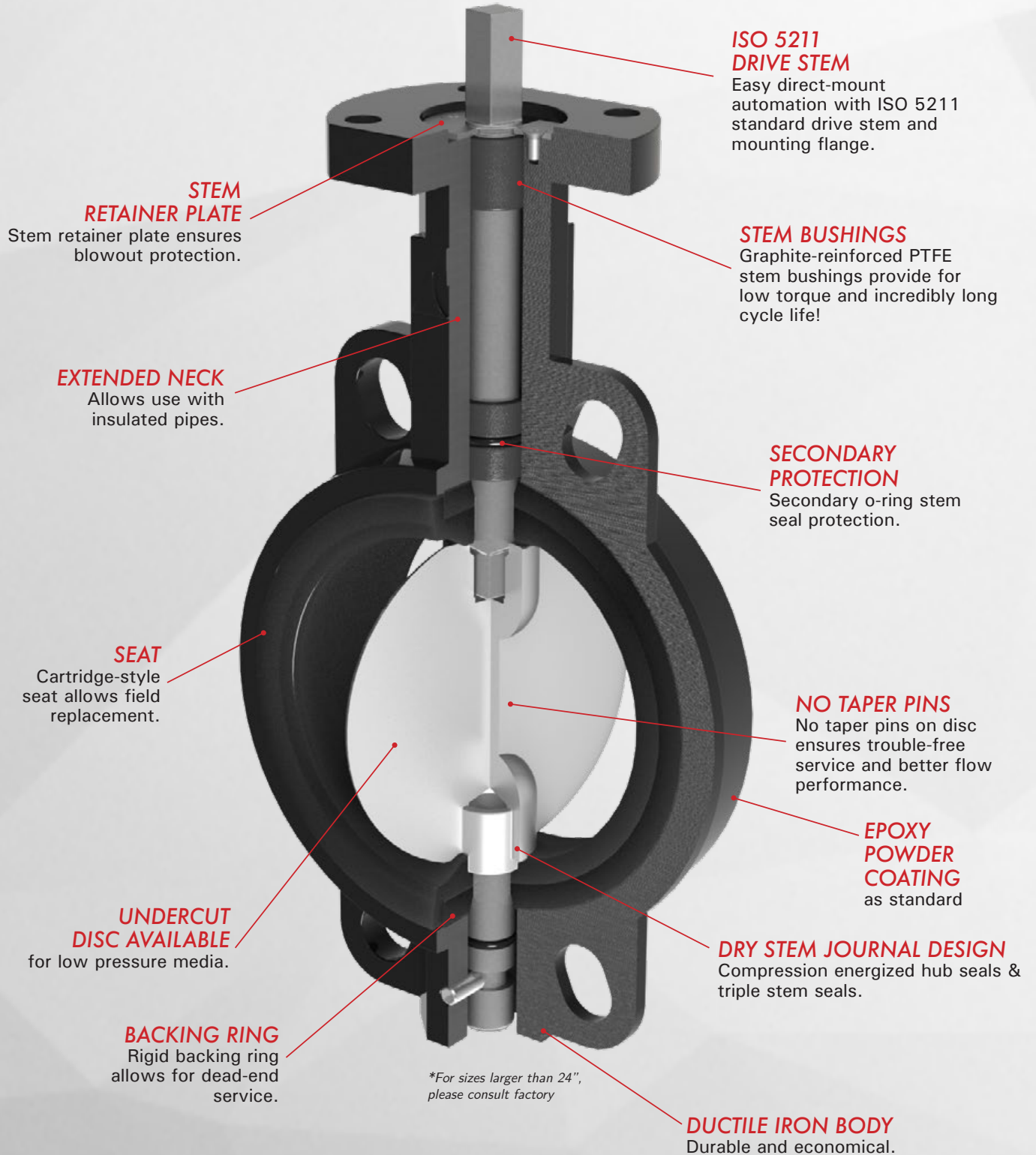

050/051 Series

- 050 Wafer Ductile Iron Body sizes 1.5" - 48"
- 051 Lug Ductile Iron Body sizes 1.5" - 48"
- Lug-style dead end service capabilities through 12":
 - 200 PSI uni-directional
 - 100 PSI bi-directional
- Install between Standard ANSI class 125/150 flanges
- 050 Wafer also compatible with PN10/PN16 flanges
- ISO 5211 square drive shaft for easy automation
- Conforms to MSS-SP-67, MSS-SP-25, API-609
- Designed for blowout-proof service
- High-Cv slim disc & 2-piece stem design 1.5"-12"
- Field repairable
- Vacuum service capable 1.5"-12" to below 10 microns
- Malleable Iron Handles available
- Cast Iron Gear Operators available



050/051 Butterfly Valves

Dimensions

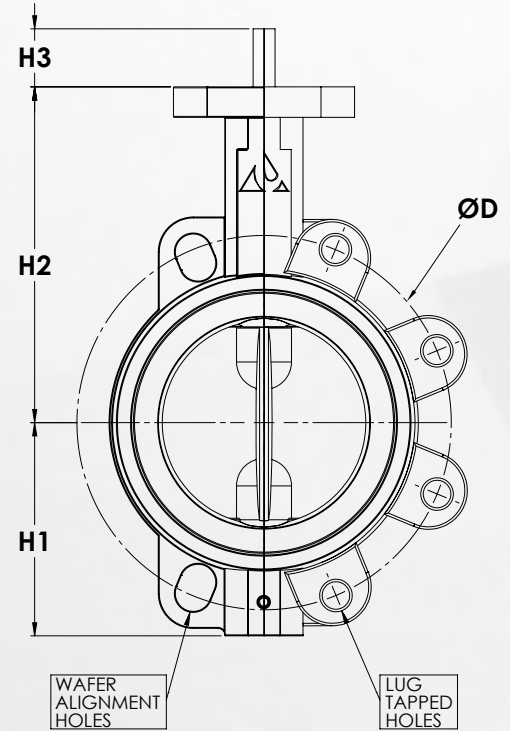
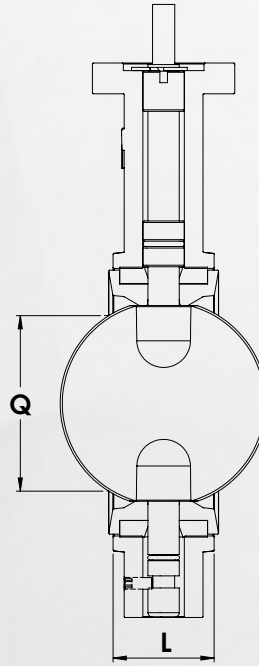
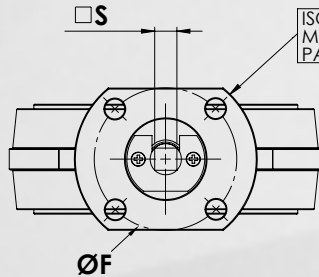

Ductile Iron Butterfly Valves

Size		L		Q		ØD		Lug Taps	Wafer Holes		H1		H2		H3		□ S		ØF		ISO
in	mm	in	mm	in	mm	in	mm	SAE Thread	in	mm	in	mm	in	mm	in	mm	in	mm	in	mm	
1½	DN40	1.3	33	0.8	21	3.88	98.5	1/2" - 13 UNC	4 x 0.7	4 x 18	2.5	64	4.9	124	1.18	30	0.354	9	1.969	50	F05
2	DN50	1.7	43	1.1	29	4.75	120.7	4 x 5/8 - 11 UNC	4 x 0.9	4 x 22	2.6	66	5.1	130	1.18	30	0.354	9	1.969	50	F05
2½	DN65	1.8	46	1.8	45	5.50	139.7	4 x 5/8 - 11 UNC	4 x 0.7	4 x 18	3.2	81	5.6	142	1.18	30	0.354	9	1.969	50	F05
3	DN75	1.8	46	2.5	62	6.00	152.4	4 x 5/8 - 11 UNC	4 x 0.7	4 x 18	3.5	89	5.8	147	1.18	30	0.354	9	1.969	50	F05
4	DN100	2.0	52	3.5	89	7.50	190.5	8 x 5/8 - 11 UNC	4 x 0.7	4 x 18	4.3	109	6.7	170	1.18	30	0.433	11	2.756	70	F07
5	DN125	2.2	56	4.6	116	8.50	215.9	8 x 3/4 - 10 UNC	4 x 0.9	4 x 22	4.8	122	7.4	188	1.18	30	0.551	14	2.756	70	F07
6	DN150	2.2	56	5.7	145	9.50	241.3	8 x 3/4 - 10 UNC	4 x 0.9	4 x 22	5.4	137	8.0	203	1.18	30	0.551	14	2.756	70	F07
8	DN200	2.4	60	7.8	197	11.75	298.5	8 x 3/4 - 10 UNC	4 x 1.0	4 x 26	6.7	170	9.4	239	1.57	40	0.669	17	4.016	102	F10
10	DN250	2.7	68	9.8	248	14.25	362.0	12 x 7/8 - 9 UNC	4 x 1.0	4 x 26	7.9	201	10.7	272	1.57	40	0.866	22	4.016	102	F10
12	DN300	3.1	78	11.7	298	17.00	431.8	12 x 7/8 - 9 UNC	4 x 1.0	4 x 26	9.3	236	12.0	305	1.57	40	0.866	22	4.016	102	F10
14	DN350	3.1	78	—	—	18.75	476.3	12 x 1 - 8 UNC	—	—	10.3	262	13.0	330	1.57	40	0.866	22	4.016	102	F10
16	DN400	4.0	102	—	—	21.25	539.8	16 x 1 - 8 UNC	—	—	11.8	300	14.2	361	2.00	51	1.063	27	5.512	140	F14
18	DN450	4.5	114	—	—	22.75	577.9	16 x 1 1/8 - 7 UNC	—	—	12.8	325	15.6	396	2.00	51	1.063	27	5.512	140	F14
20	DN500	5.0	127	—	—	25.00	635.0	20 x 1 1/8 - 7 UNC	—	—	14.2	361	17.3	439	2.52	64	1.063	27	6.496	165	F16
24	DN600	6.1	154	—	—	29.50	749.3	20 x 1 1/4 - 7 UNC	—	—	16.5	419	19.7	500	2.76	70	1.417	36	6.496	165	F16

Optional Infinite Locking Plates

Valve Sizes		ILP Plate	ILP Arm
in	mm		
1.5-3"	DN40-75	02A	07S
4"	DN100	02/02A	03/03S
5-6"	DN125-150	02/02A	04/04S
8"*	DN200*	03/03A	05/05S
10-12"*	DN250-300*	03/03A	06/06S

*Recommended operation with a gear operator or an actuator for sizes 8"-12"



Over-Travel on Infinite 2-Position Lock Option Allows Disc to Wipe Seat

Locking Arm (Included w/ Plate)



The standard 10-position throttle plate has grooves that allow the handle to snap in place for repeatability and to prevent unintentional movement of the disc.

For even more control, Infinite Lever Plates (ILP) and arms are available, which allow the valve to be fixed in place with a bolt at any position. It is important to note that the ILP plates and locking arms can be padlocked in the full open and full closed positions only, to prevent tampering or accidental operation.

050/051 Butterfly Valves Gear and Handle Options

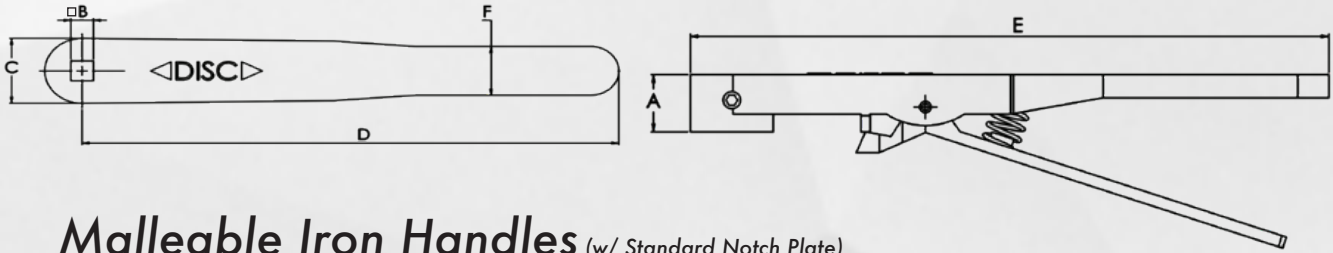

Malleable Iron Handles (w/ Standard Notch Plate)

Handle Part #	Valve Sizes		A		□B		C		D		E		F		Weight	
	in	mm	in	mm	in	mm	in	mm	in	mm	in	mm	in	mm	lbs	kg
HND-M01	1.5-3"	DN50-75	1.0	26	0.35	9.0	1.3	33	8.9	225	9.4	240	1.1	28	1.1	2.4
HND-M02	4"	DN100	1.0	26	0.43	11.0	1.4	35	10.2	260	11.0	280	1.1	28	1.2	2.6
HND-M03	5-6"	DN125-150	1.0	26	0.55	14.0	1.4	35	10.2	260	11.0	280	1.1	28	1.3	2.9
HND-M04	8"*	DN200*	1.2	30	0.67	17.0	1.9	49	14.0	355	15.2	385	1.3	32	2.6	5.7
HND-M05	10-12"*	DN250-300*	1.2	30	0.87	22.0	1.9	49	14.0	355	15.2	385	1.3	32	2.6	5.7

*Recommended operation with a gear operator or an actuator for sizes 8"-12"

Cast Iron Gear Operators

Valve Sizes		Gear Operator	A		B		ØH		Weight		Max Torque		Rim Pull @ Max DP	
in	mm		in	mm	in	mm	in	mm	lbs	kg	in-lbs	Nm	lbf	N
1.5-4	DN50-100	GO-01-ISO	1.7	43	3.2	81	6	152	2.8	1.3	1330	150	20	89
5-6	DN125-150	GO-02-ISO	2.5	64	3.6	91	6	152	5.6	2.5	1770	200	46	205
8-10	DN200-250	GO-03-ISO	2.4	61	4.7	119	10	254	11.5	5.2	4425	500	74	329
12-14	DN300-350	GO-04A-ISO	2.6	66	6.5	165	12	305	22.2	10.1	8850	1000	86	383
16-18	DN400-450	GO-05B-ISO	3.5	89	7.9	201	16	406	40.8	18.5	15900	1800	102	454
20	DN500	GO-06B-ISO	5.0	127	10.1	257	16	406	78.1	35.4	30090	3400	107	476
24	DN600	GO-07-ISO	6.1	155	12.4	315	16	406	101	45.8	39825	4500	127	565

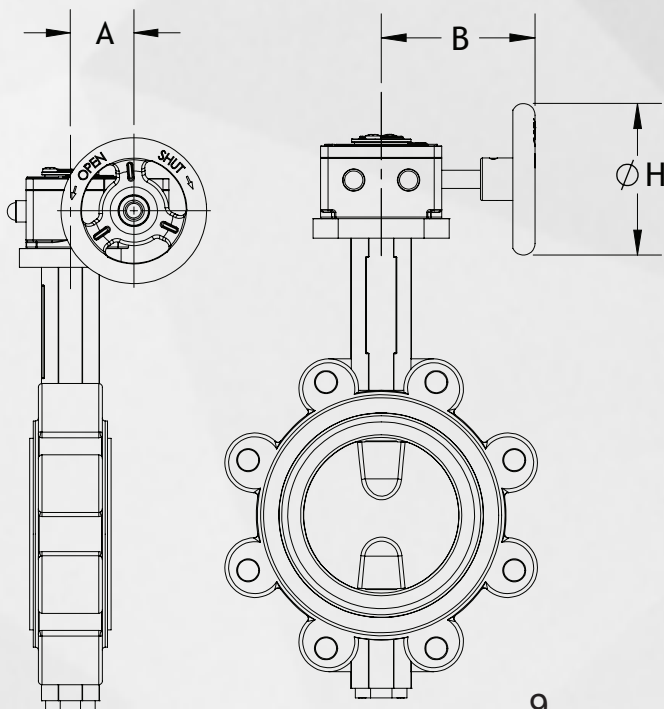

050/051 Butterfly Valves (1.5"-12") Exploded View



ALUMINUM
TAG DETAIL

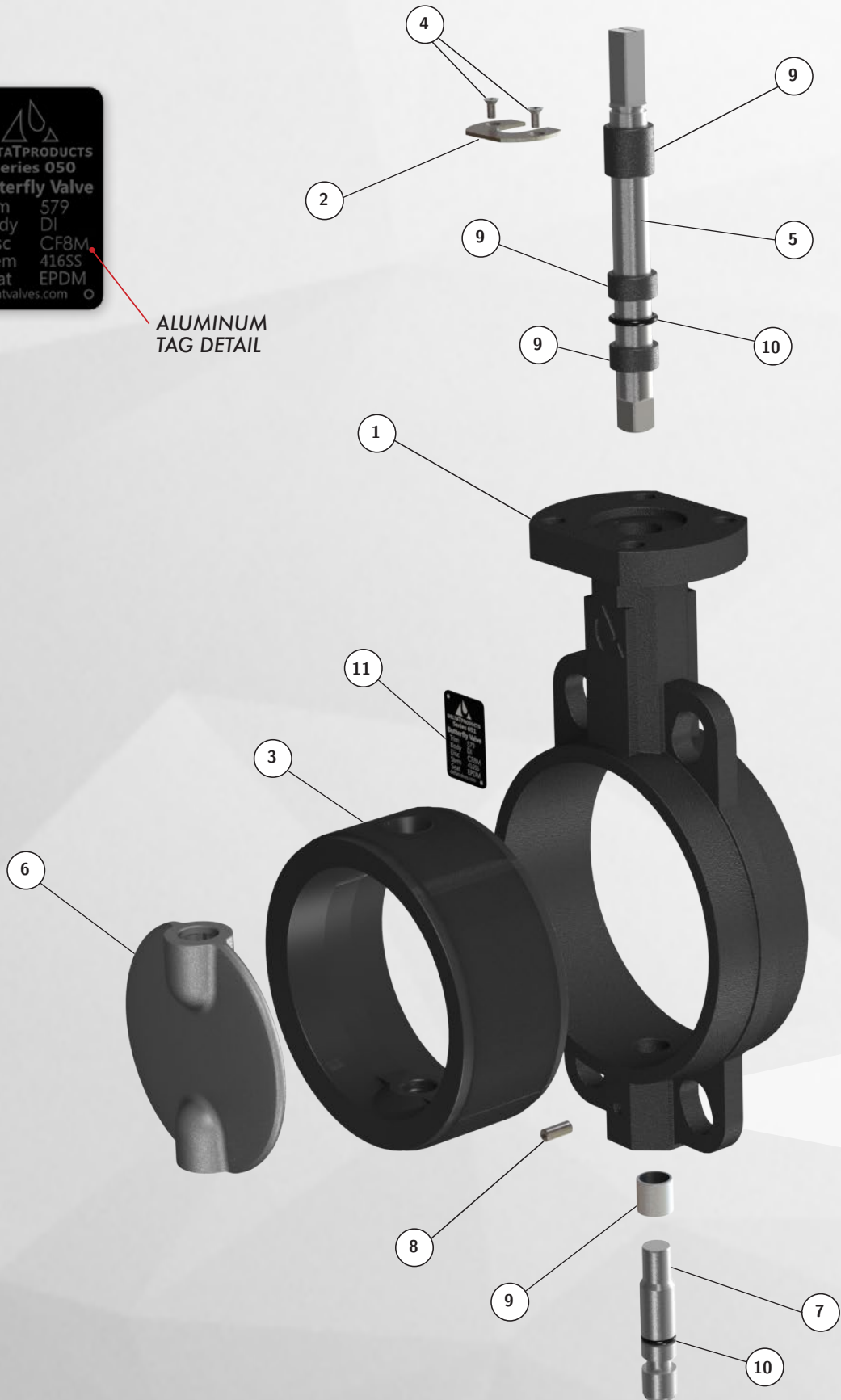

050/051 Butterfly Valves (1.5"-12") Materials and Stem Details

Bill of Materials

Item	Description	Materials
1	Body	Ductile Iron ASTM A536
2	Stem Retainer	Carbon Steel, Plated
3	Seat	See Pg 4 or 26
4	Stem Retainer Screws	Carbon Steel, Plated
5	Upper Stem	Stainless Steel ASTM A582, Alloy 416, 316SS Option
6	Disc	See Pg 4 or 28
7	Lower Stem	Stainless Steel ASTM A582, Alloy 416, 316SS Option
8	Lower Stem Retainer	Carbon Steel, Plated
9	Bushing	PTFE/Graphite
10	O-Ring	EPDM, BUNA-N, Fluoroelastomer
11	Nameplate Tag	Aluminum (see detail)



Lower Stem Detail

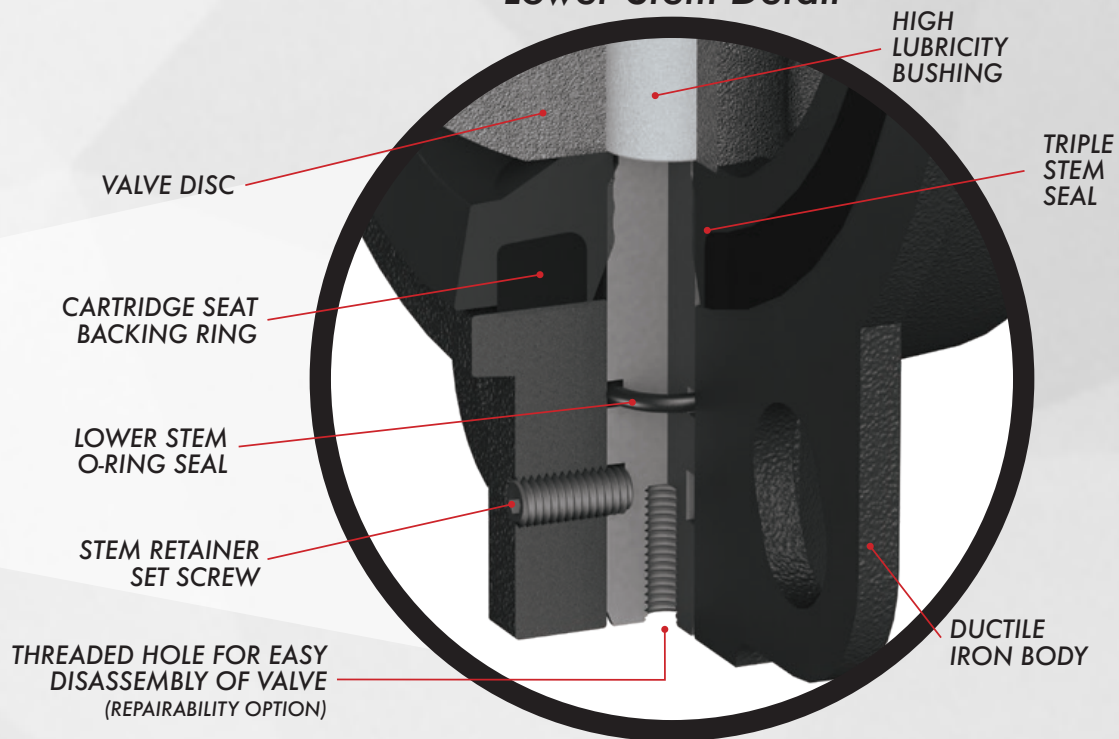

050/051 Butterfly Valves (14"-24") Exploded View



ALUMINUM
TAG DETAIL

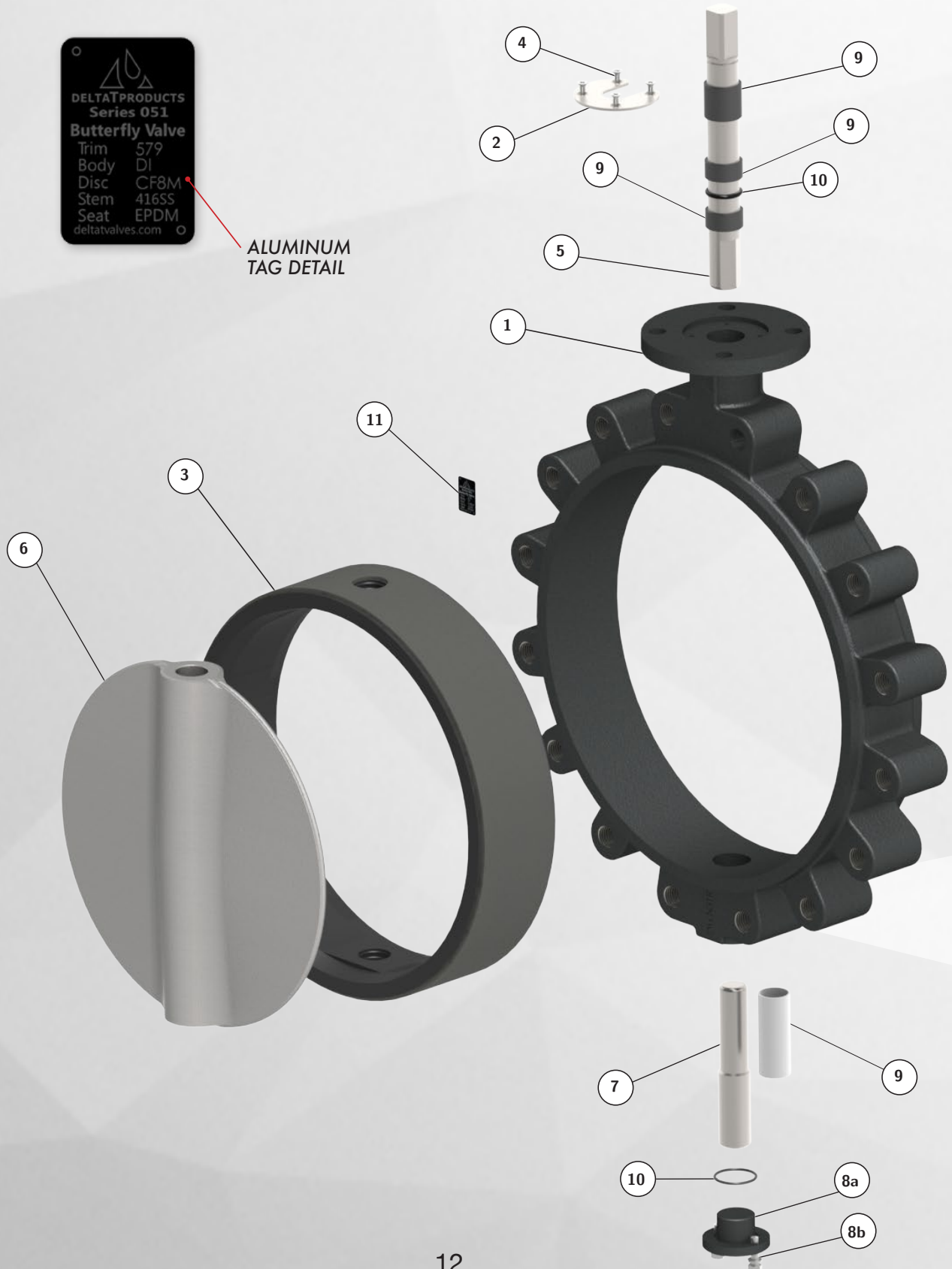

050/051 Butterfly Valves (14"-24") Materials and Stem Details

Bill of Materials

Item	Description	Materials
1	Body	Ductile Iron ASTM A536
2	Stem Retainer	Carbon Steel, Plated
3	Seat	See Pg 4 or 26
4	Stem Retainer Screws	Carbon Steel, Plated
5	Upper Stem	Stainless Steel ASTM A582, Alloy 416 or 410, 316SS Option
6	Disc	See Pg 4 or 28
7	Lower Stem	Stainless Steel ASTM A582, Alloy 416 or 410, 316SS Option
8a	Lower Stem Retainer	Ductile Iron ASTM A536
8b	Lower Stem Retainer Bolts and Washers	Carbon Steel, Plated
9	Bushing	PTFE/Graphite
10	O-Ring	EPDM, BUNA-N, Fluoroelastomer
11	Nameplate Tag	Aluminum (see detail)



Lower Stem Detail

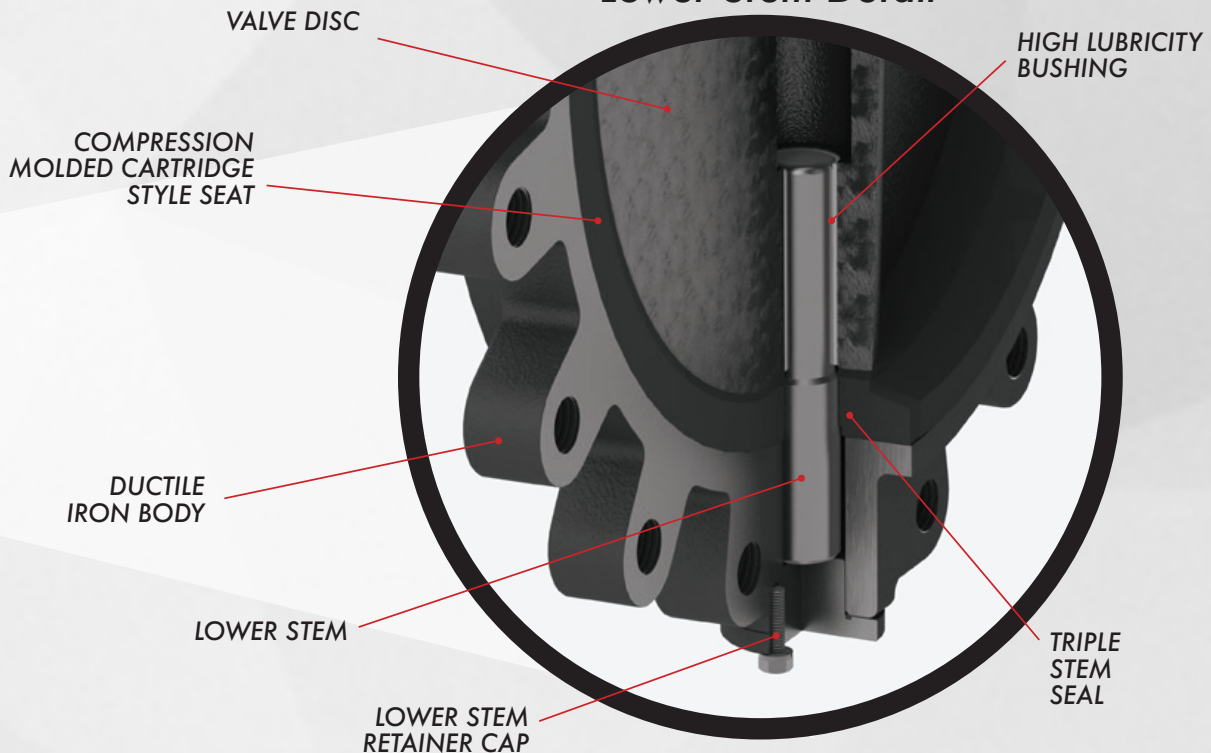

050/051 Butterfly Valves

Torques, Weights, & Service Factor Rating

Seating Torques (in-lbs)

Size (in)	STANDARD SEAT				UNDERCUT DISC		PTFE SEAT	
	Pressure Differential (ΔP in PSI)							
	50 ΔP	100 ΔP	150 ΔP	200 ΔP	50 ΔP	50 ΔP	100 ΔP	150 ΔP
1½	105	111	117	124	—	—	—	—
2	105	111	117	124	—	144	148	150
2½	133	143	159	184	—	161	165	168
3	191	203	218	247	—	299	304	310
4	283	316	343	373	200	392	409	425
5	428	479	540	631	330	771	793	814
6	636	720	799	909	440	1074	1113	1151
8	1239	1273	1411	1505	820	2106	2177	2257
10	2567	2710	2832	3105	1150	3151	3301	3452
12	3153	3307	3671	4305	2400	4186	4443	4691
14	3858	4138	4337	—	Consult Manufacturer			
16	5413	6027	7466	—				
18	6833	8121	10090	—				
20	9820	10527	13367	—				
24	15909	17005	21041	—				

The torque values listed above do not include a safety factor. It is recommended that a safety factor of 20% be added to these numbers for standard self-lubricating service. For water, dry air, solvents, abrasives, powder, and dust service, see service factor guide chart on next page.

Weights

Size		Wafer		Lug		Individual Handle		Individual Gear Operator	
in	mm	lbs	kg	lbs	kg	lbs	kg	lbs	kg
1½	DN40	4.2	1.9	—	—	1.1	2.4	2.8	1.3
2	DN50	4.2	1.9	5.2	2.4	1.1	2.4	2.8	1.3
2½	DN65	5.5	2.5	6.5	3.0	1.1	2.4	2.8	1.3
3	DN75	6.1	2.8	7.3	3.3	1.1	2.4	2.8	1.3
4	DN100	9.0	4.1	12.5	5.7	1.3	2.6	2.8	1.3
5	DN125	12.6	5.7	16.9	7.7	1.3	2.9	5.6	2.5
6	DN150	15.1	6.9	20.4	9.3	1.3	2.9	5.6	2.5
8	DN200	27.0	12.3	33.3	15.1	2.6	5.7	11.5	5.2
10	DN250	40.8	18.5	54.5	24.7	2.6	5.7	11.5	5.2
12	DN300	60.7	27.6	76.2	34.6	2.6	5.7	22.2	10.1
14	DN350	86.9	39.4	131.5	59.7	—	—	22.2	10.1
16	DN400	121.4	55.1	194.8	88.4	—	—	40.8	18.5
18	DN450	154.2	69.9	235.5	106.8	—	—	40.8	18.5
20	DN500	208.5	94.6	340.5	154.4	—	—	78.1	35.4
24	DN600	387.9	176.0	503.0	228.2	—	—	101	45.8



Cv Values Valve Sizing Coefficients (US-GPM/ ΔP)

Size (in)	Disc Position								
	90°	80°	70°	60°	50°	40°	30°	20°	10°
1½	99	76	59	41	32	16	7	1.8	0.1
2	132	120	86	58	42	22	11	2	0.1
2½	256	202	142	98	65	37	20	4	0.2
3	505	392	198	125	86	38	21	8	0.3
4	936	702	401	232	140	77	35	14	0.4
5	1109	922	625	392	232	132	62	29	0.9
6	2531	2009	1105	611	372	203	96	42	2.1
8	4812	3555	1901	1211	726	401	191	65	3.2
10	7498	6183	3740	2065	1232	695	321	151	3.9
12	9928	8805	5905	3178	1909	1065	495	234	5
14	12915	10854	7220	4560	2771	1554	712	338	5.8
16	16626	14961	9909	6289	3780	2133	980	460	8
18	23705	19743	13178	8325	5029	2822	1301	613	10
20	27915	25396	16928	10698	6468	3623	1678	790	12
24	43212	39206	26128	16550	9807	5567	2521	860	21

The valve sizing coefficient is referred to as "Cv" and is the rate of water flow in gallons per minute (GPM) through a given opening at a pressure drop (ΔP) of 1 PSI at standard room temperature. The recommended angle of opening for valve sizing is between 50° and 70° open.

Service Factor Rating

Service Condition	Service Type	Media Type	Safety Factor	Multiplier
1	Ideal	Lubricating Oil	20%	1.20
2	Normal	Water	30%	1.30
3	Severe	Dry Air, Solvents	50%	1.50
4	Extreme	Abrasives	100%	2.00

This service factor chart is a suggested guide only. Actual service conditions will vary due to dynamic flow conditions and may require adjustments to the applied safety factor.

Pressure Rating

Size	050/051 SERIES		
	1.5"-12"	14"-48"	2"-12" (PTFE)
Bidirectional Shutoff	200 PSI	150 PSI	150 PSI

650/651 Butterfly Valves

Features & Benefits

Stainless Steel Body - Lug & Wafer Styles

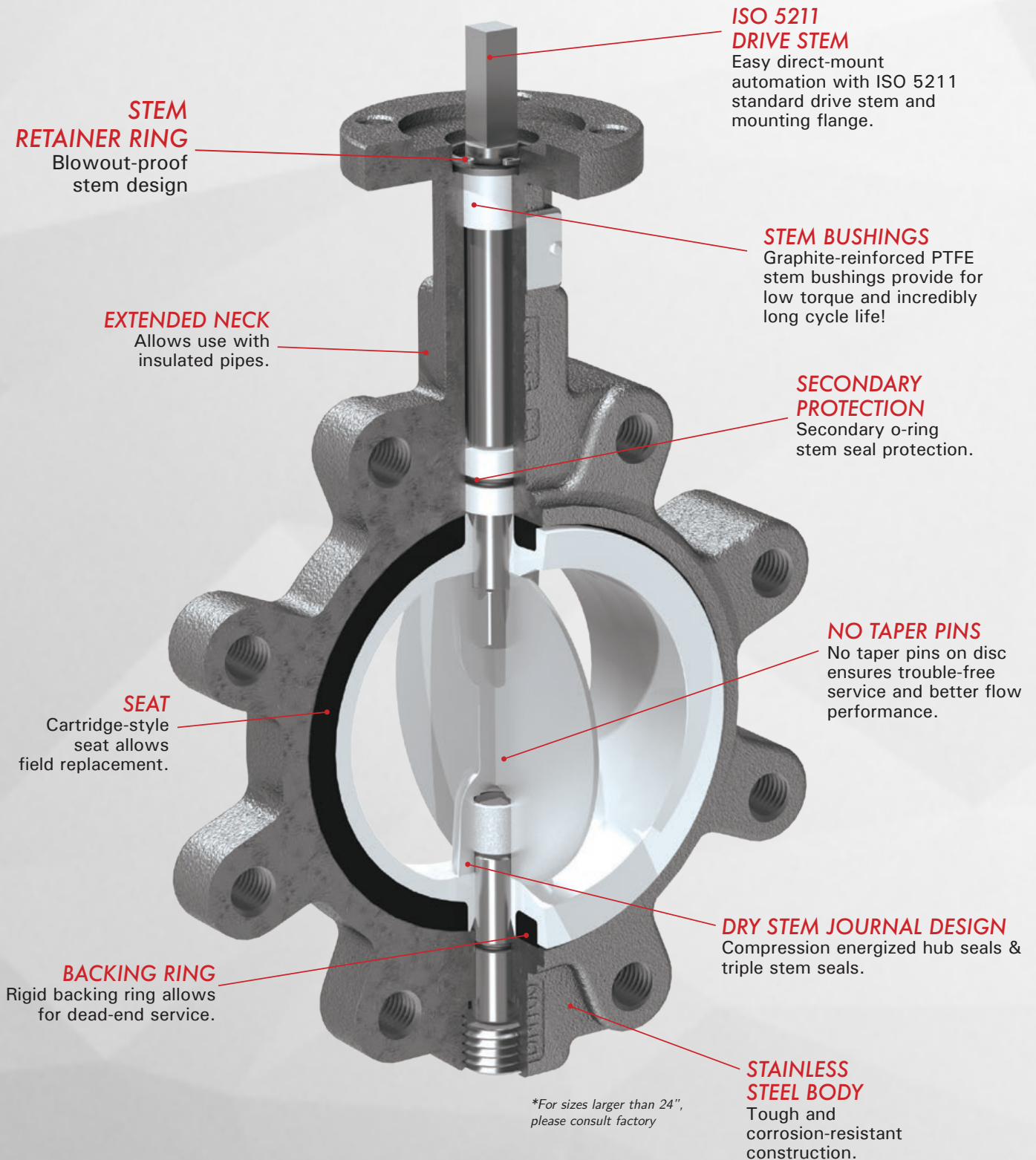

650/651 Series

- 650 Wafer Stainless Steel Body sizes 2" - 24"
- 651 Lug Stainless Steel Body sizes 2" - 24"
- Lug-style dead end service capabilities through 12"
 - 200 PSI uni-directional
 - 100 PSI bi-directional
- Install between Standard ANSI class 125/150 flanges
- ISO 5211 square drive shaft for easy automation
- Conforms to MSS-SP-67, MSS-SP-25, API-609
- Designed for blowout-proof service
- High-Cv slim disc & 2-piece stem design 2"-12"
- Field repairable
- Vacuum service capable 2" thru 12" to 10 microns
- 304 SS Handles available
- Cast Iron Gear Operators available

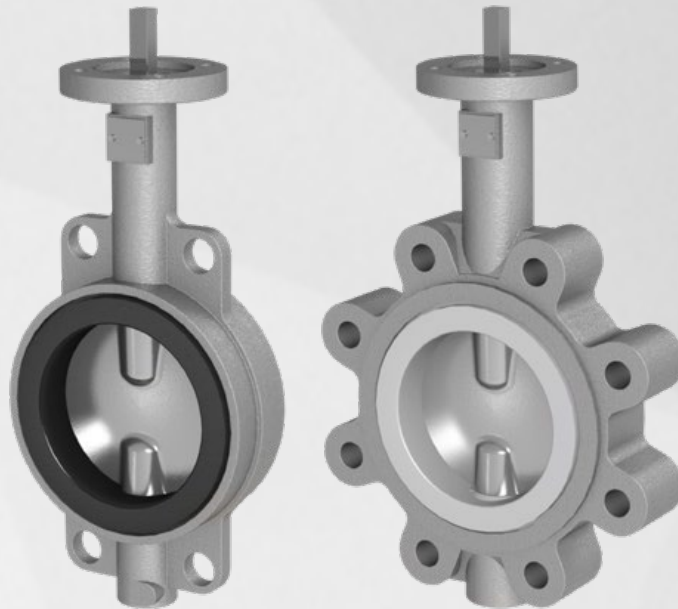

650/651 Butterfly Valves

Dimensions

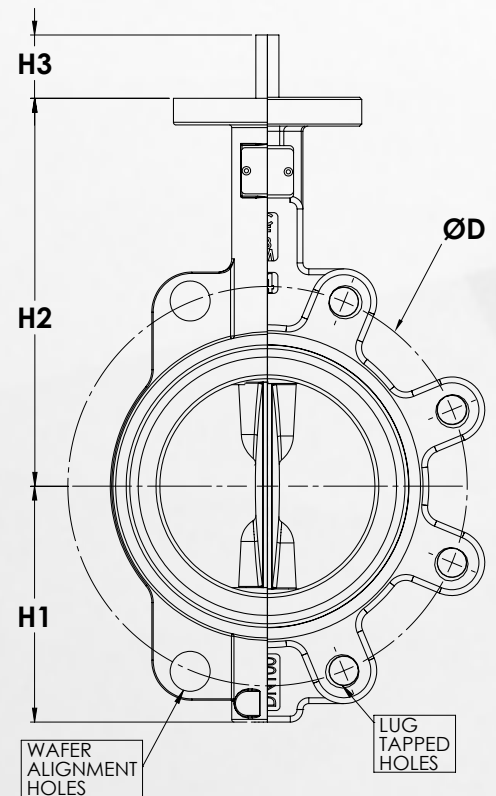
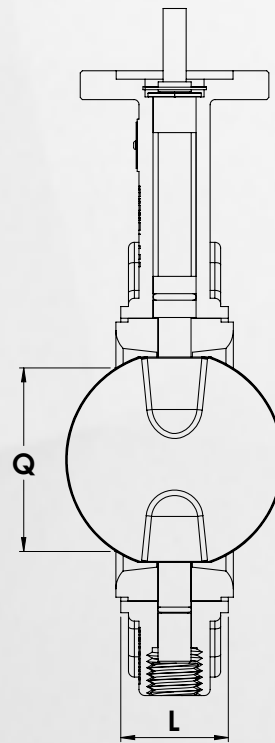
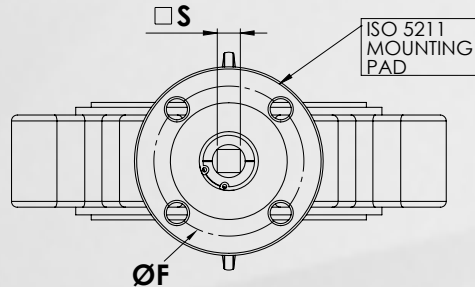

Stainless Steel Butterfly Valves

Size		L		Q		ØD		Lug Taps	Wafer Holes		H1		H2		H3		S		ØF		ISO
in	mm	in	mm	in	mm	in	mm	SAE Thread	in	mm	in	mm	in	mm	in	mm	in	mm	in	mm	
2	DN50	1.7	43	1.1	29	4.75	120.7	4 x 5/8 -11 UNC	4 x 0.9	4 x 22	2.6	66	5.1	130	1.18	30	0.354	9	1.969	50	F05
2½	DN65	1.8	46	1.8	45	5.50	139.7	4 x 5/8 -11 UNC	4 x 0.7	4 x 18	3.2	81	5.6	142	1.18	30	0.354	9	1.969	50	F05
3	DN75	1.8	46	2.5	62	6.00	152.4	4 x 5/8 -11 UNC	4 x 0.7	4 x 18	3.5	89	5.8	147	1.18	30	0.433	11	1.969	50	F05
4	DN100	2.0	52	3.5	89	7.50	190.5	8 x 5/8 -11 UNC	4 x 0.7	4 x 18	4.3	109	6.7	170	1.18	30	0.433	11	2.756	70	F07
5	DN125	2.2	56	4.6	116	8.50	215.9	8 x 3/4 -10 UNC	4 x 0.9	4 x 22	4.8	122	7.4	188	1.18	30	0.551	14	2.756	70	F07
6	DN150	2.2	56	5.7	145	9.50	241.3	8 x 3/4 -10 UNC	4 x 0.9	4 x 22	5.4	137	8.0	203	1.18	30	0.551	14	2.756	70	F07
8	DN200	2.4	60	7.8	197	11.75	298.5	8 x 3/4 -10 UNC	4 x 1.0	4 x 26	6.7	170	9.4	239	1.57	40	0.669	17	4.016	102	F10
10	DN250	2.7	68	9.8	248	14.25	362.0	12 x 7/8 -9 UNC	4 x 1.0	4 x 26	7.9	201	10.7	272	1.57	40	0.866	22	4.016	102	F10
12	DN300	3.1	78	11.7	298	17.00	431.8	12 x 7/8 -9 UNC	4 x 1.0	4 x 26	9.3	236	12.0	305	1.57	40	0.866	22	4.016	102	F10
14	DN350	3.1	78	—	—	18.75	476.3	12 x 1 -8 UNC	—	—	10.3	262	13.0	330	1.57	40	0.866	22	4.016	102	F10
16	DN400	4.0	102	—	—	21.25	539.8	16 x 1 -8 UNC	—	—	11.8	300	14.2	361	2.00	51	1.063	27	5.512	140	F14
18	DN450	4.5	114	—	—	22.75	577.9	16 x 1 1/8 -7 UNC	—	—	12.8	325	15.6	396	2.00	51	1.063	27	5.512	140	F14
20	DN500	5.0	127	—	—	25.00	635.0	20 x 1 1/8 -7 UNC	—	—	14.2	361	17.3	439	2.52	64	1.063	27	6.496	165	F16
24	DN600	6.1	154	—	—	29.50	749.3	20 x 1 1/4 -7 UNC	—	—	16.5	419	19.7	500	2.76	70	1.417	36	6.496	165	F16

Optional Infinite Locking Plates

Valve Sizes		ILP Plate	ILP Arm
in	mm		
2-2.5"	DN50-65	02A	07S
3"	DN75	02A	03S
4"	DN100	02A	03S
5-6"	DN125-150	02A	04S
8"	DN200*	03A	05S
10-12"	DN250-300*	03A	06S

*Recommended operation with a gear operator or an actuator for sizes 8"-12"

Optional Infinite Lever Plate

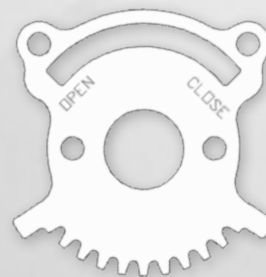

Locking Arm (Included w/ Plate)



The **standard** 10-position throttle plate has grooves that allow the handle to snap in place for repeatability and to prevent unintentional movement of the disc.

For even more control, **Infinite Lever Plates (ILP)** and arms are available, which allow the valve to be fixed in place with a bolt at any position. It is important to note that the ILP plates and locking arms can be padlocked in the full open and full closed positions only, to prevent tampering or accidental operation.

650/651 Butterfly Valves Gear and Handle Options

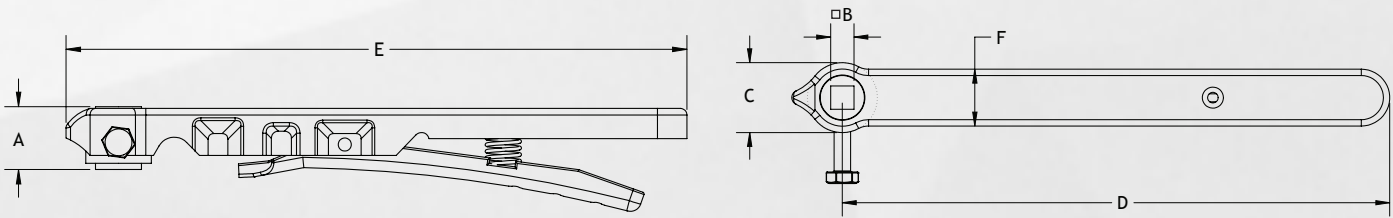

Stainless Steel Handles (w/ Standard Notch Plate)

Handle Part #	Valve Sizes		A		□B		C		D		E		F		Weight	
	in	mm	in	mm	in	mm	in	mm	in	mm	in	mm	in	mm	lbs	kg
HND-S01	2-2.5"	DN50-75	1.1	28	0.35	9.0	1.3	34	10.2	260	11.2	285	1.1	27	1.0	2.2
HND-S02	3-4"	DN100	1.1	28	0.43	11.0	1.3	34	10.2	260	11.2	285	1.1	27	1.0	2.2
HND-S03	5-6"	DN125-150	1.1	28	0.55	14.0	1.3	34	10.2	260	11.2	285	1.1	27	1.0	2.2
HND-S04	8"*	DN200*	1.2	30	0.67	17.0	1.9	49	14.7	373	15.7	400	1.3	33	2.5	5.5
HND-S05	10-12"*	DN250-300*	1.2	30	0.87	22.0	1.9	49	14.7	373	15.7	400	1.3	33	2.5	5.5

*Recommended operation with a gear operator or an actuator for sizes 8"-12"

Cast Iron Gear Operators

Valve Sizes		Gear Operator	A		B		ØH		Weight		Output Torque		Rim Pull @ Max DP	
in	mm		in	mm	in	mm	in	mm	lbs	kg	in-lbs	Nm	lbf	N
2-4	DN50-100	GO-01-ISO	1.7	43	3.2	81	6	152	2.8	1.3	1330	150	20	89
5-6	DN125-150	GO-02-ISO	2.5	64	3.6	91	6	152	5.6	2.5	1770	200	46	205
8-10	DN200-250	GO-03-ISO	2.4	61	4.7	119	10	254	11.5	5.2	4425	500	74	329
12-14	DN300-350	GO-04A-ISO	2.6	66	6.5	165	12	305	22.2	10.1	8850	1000	86	383
16-18	DN400-450	GO-05B-ISO	3.5	89	7.9	201	16	406	40.8	18.5	15900	1800	102	454
20	DN500	GO-06B-ISO	5.0	127	10.1	257	16	406	78.1	35.4	30090	3400	107	476
24	DN600	GO-07-ISO	6.1	155	12.4	315	16	406	101	45.8	39825	4500	127	565

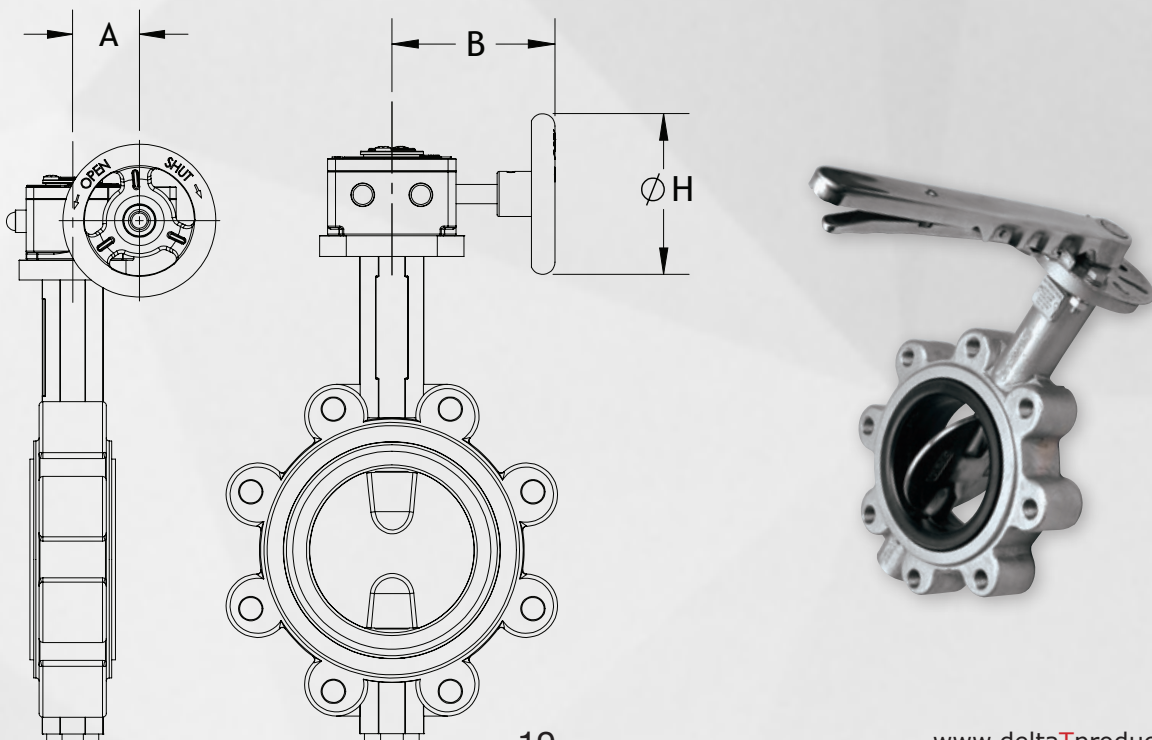

650/651 Butterfly Valves (2"-12")

Exploded View

BUTTERFLY VALVE

- BODY: CF8M
- DISC: CF8M
- SHAFT: SS431
- SEAT: PTFE
- ANSI: 150

STAINLESS STEEL
TAG DETAIL

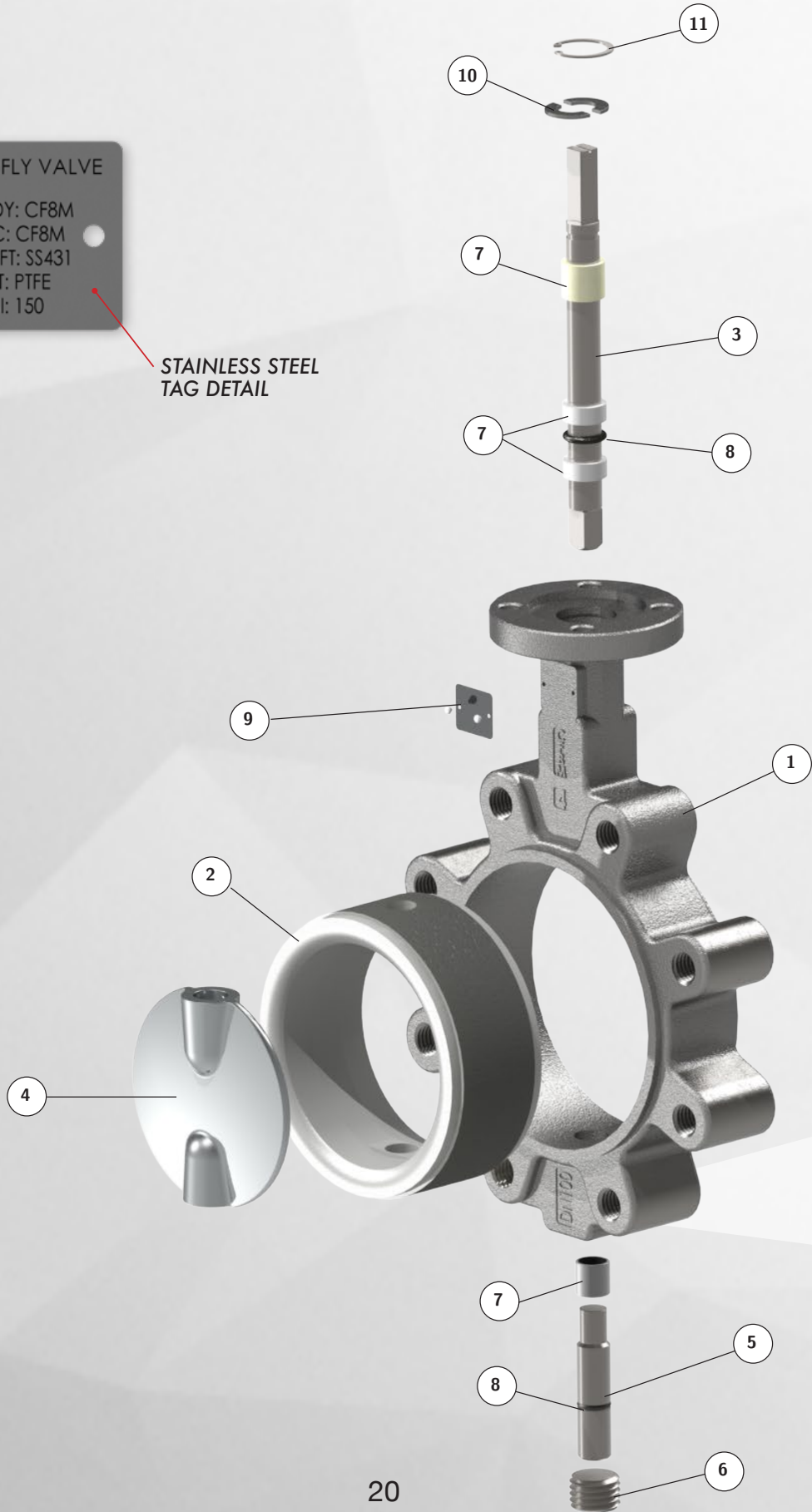

650/651 Butterfly Valves (2"-12") Materials and Stem Detail

Bill of Materials

Item	Description	Materials
1	Body	ASTM A351 grade CF8M
2	Seat	See Pg 4 or 26
3	Upper Stem	ASTM A276 431, 316SS Option
4	Disc	See Pg 4 or 28
5	Lower Stem	ASTM A276 431, 316SS Option
6	Lower Stem Retainer	304 SS
7	Stem Bushing	PTFE lined fiberglass
8	O-ring	Fluoroelastomer
9	Nameplate Tag	Stainless Steel (see detail)
10	Split Washer	1Cr13
11	Snap Ring	304 SS



Lower Stem Detail

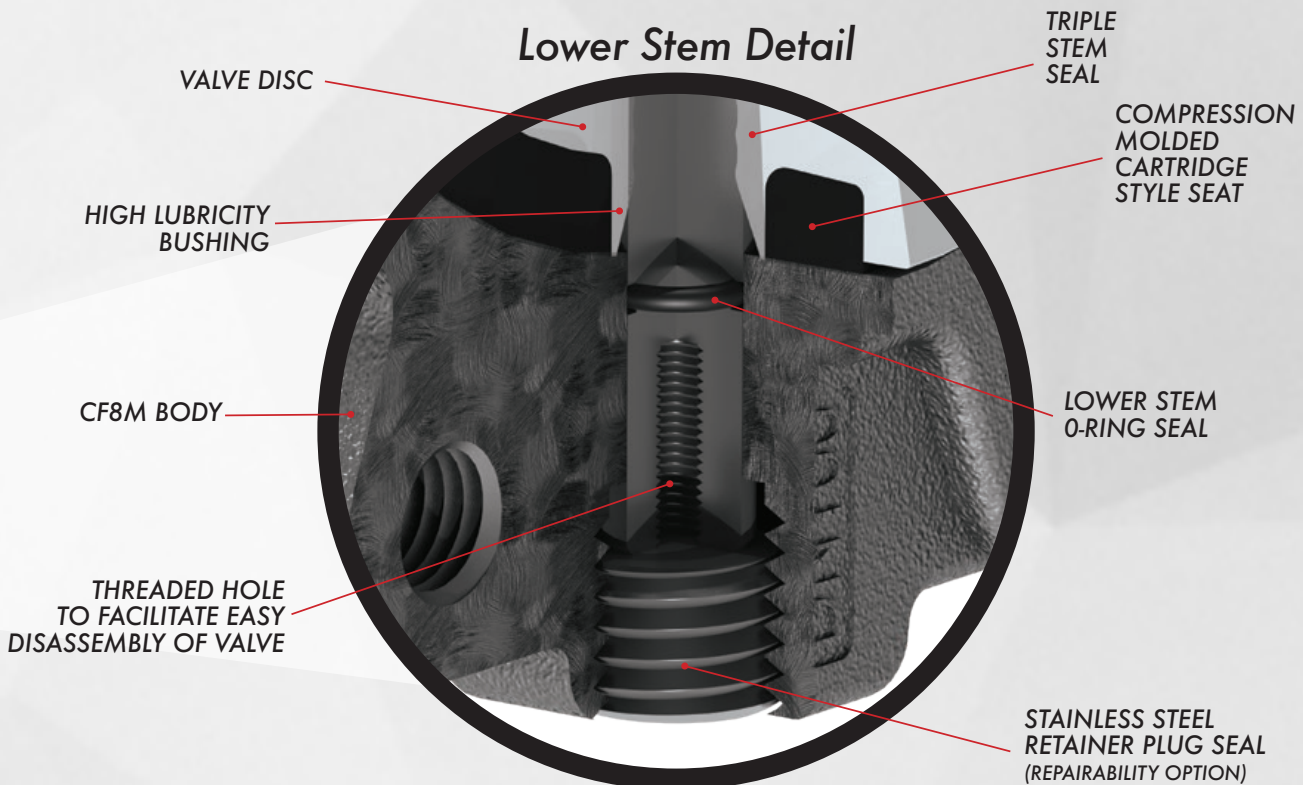

650/651 Butterfly Valves (14"-24") Exploded View

BUTTERFLY VALVE
● BODY: CF8M ●
● DISC: CF8M ●
● SHAFT: SS431 ●
● SEAT: PTFE ●
● ANSI: 150 ●

STAINLESS STEEL
TAG DETAIL

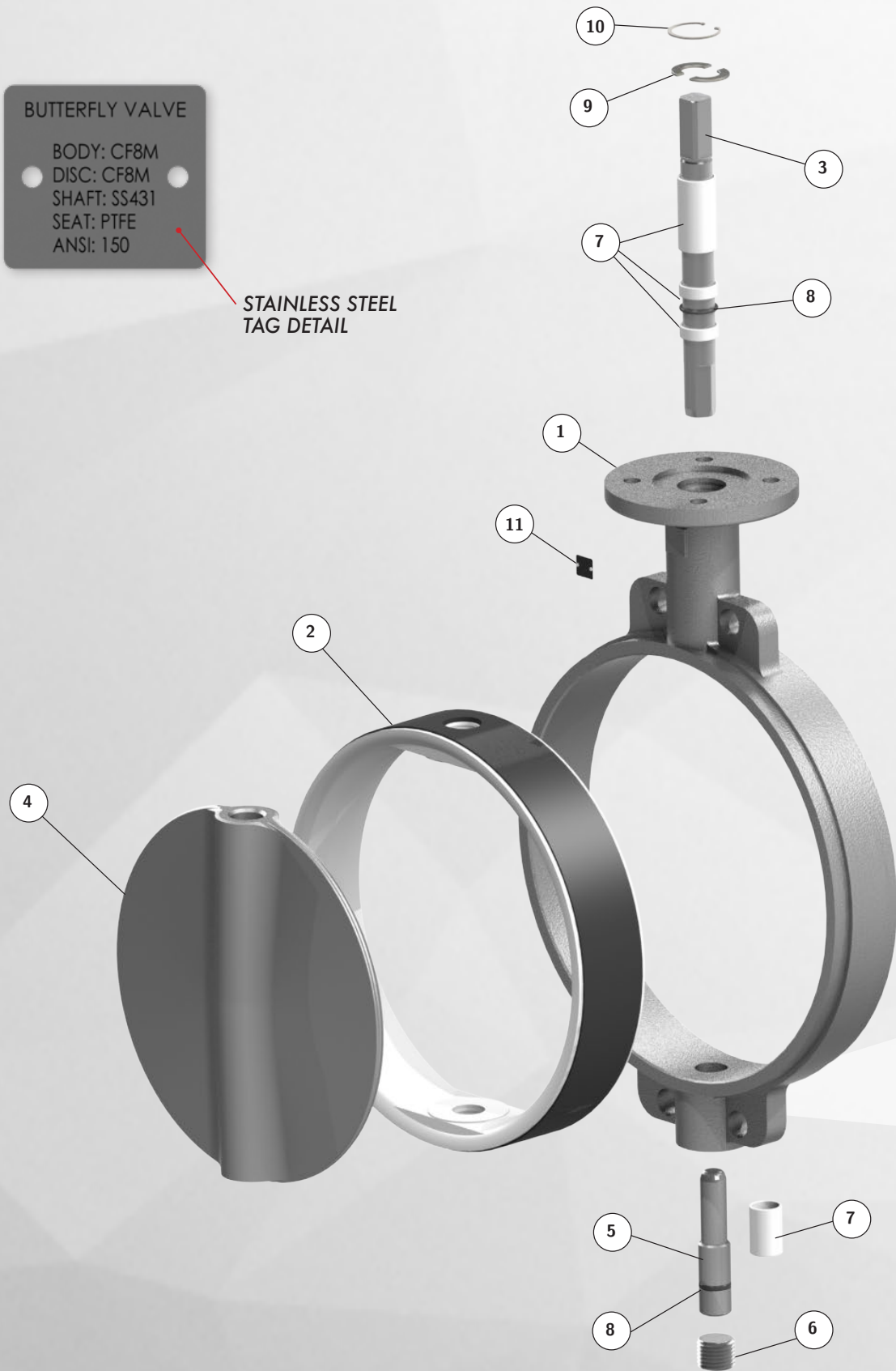

650/651 Butterfly Valves (14"-24") Materials and Stem Detail

Bill of Materials

Item	Description	Materials
1	Body	ASTM A351 grade CF8M
2	Seat	See Pg 4 or 26
3	Upper Stem	ASTM A276 431, 316SS Option
4	Disc	See Pg 4 or 28
5	Lower Stem	ASTM A276 431, 316SS Option
6	Lower Stem Retainer	304 SS
7	Stem Bushing	PTFE lined fiberglass
8	O-ring	Fluoroelastomer
9	Split Washer	1Cr13
10	Snap Ring	304 SS
11	Nameplate Tag	Stainless Steel (see detail)

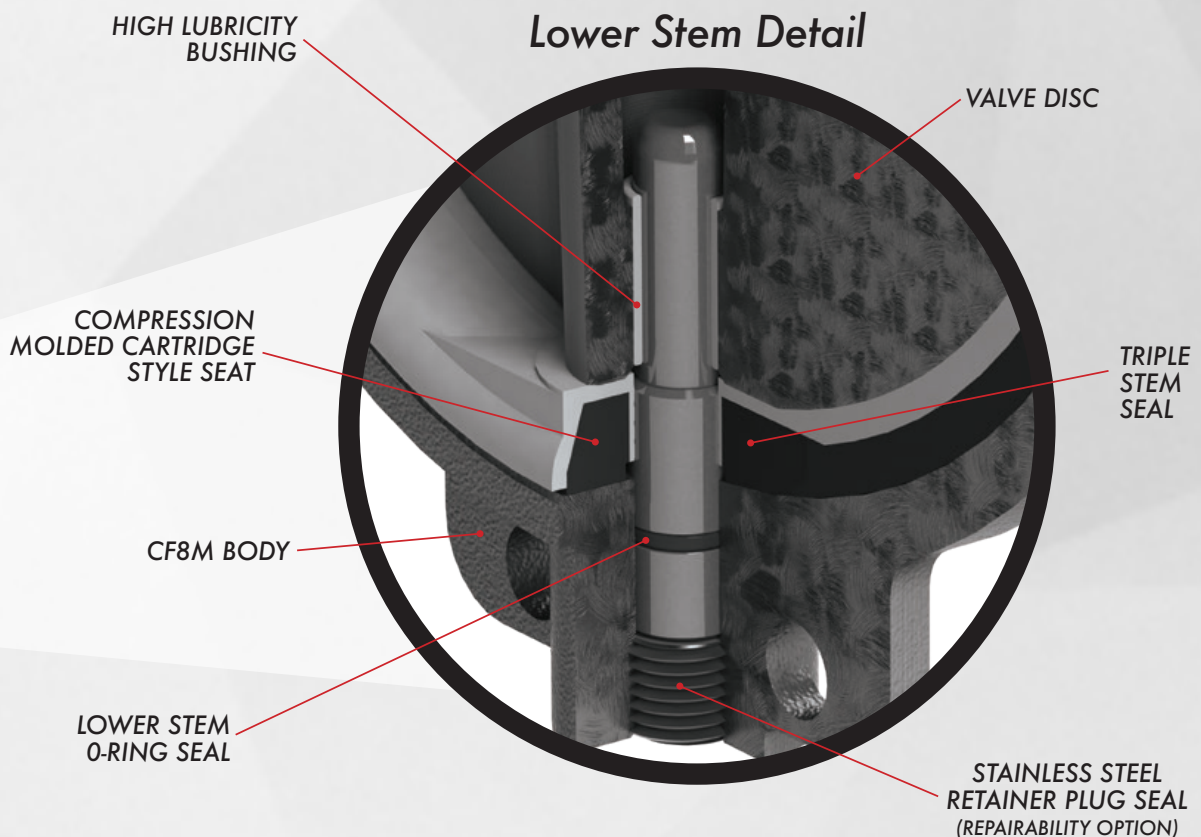

650/651 Butterfly Valves

Torque & Service Factor Ratings

Seating Torques (in-lbs)

Size (in)	STANDARD SEAT				UNDERCUT DISC	PTFE SEAT		
	Pressure Differential (ΔP in PSI)							
	50 ΔP	100 ΔP	150 ΔP	200 ΔP	50 ΔP	50 ΔP	100 ΔP	150 ΔP
2	105	111	117	124	—	144	148	150
2½	133	143	159	184	—	161	165	168
3	191	203	218	247	—	299	304	310
4	283	316	343	373	200	392	409	425
5	428	479	540	631	330	771	793	814
6	636	720	799	909	440	1074	1113	1151
8	1239	1273	1411	1505	820	2106	2177	2257
10	2567	2710	2832	3105	1150	3151	3301	3452
12	3153	3307	3671	4305	2400	4186	4443	4691
14	3858	4138	4337	—	Consult Manufacturer			
16	5413	6027	7466	—				
18	6833	8121	10090	—				
20	9820	10527	13367	—				
24	15909	17005	21041	—				

The torque values listed above do not include a safety factor. It is recommended that a safety factor of 20% be added to these numbers for standard self-lubricating service. For water, dry air, solvents, abrasives, powder, and dust service, see service factor guide chart on next page.

Weights

Size		Wafer Weight		Lug Weight		Individual Handle		Individual Gear Operator	
in	mm	lbs	kg	lbs	kg	lbs	kg	lbs	kg
2	DN50	6.0	2.7	10.4	4.7	1.0	2.4	2.8	1.3
2½	DN65	7.5	3.4	11.2	5.1	1.0	2.4	2.8	1.3
3	DN75	8.4	3.8	19.0	8.6	.9	2.4	2.8	1.3
4	DN100	11.5	5.2	21.6	9.8	.9	2.6	2.8	1.3
5	DN125	16.1	7.3	28.4	12.9	.9	2.9	5.6	2.5
6	DN150	18.3	8.3	31.3	14.2	.9	2.9	5.6	2.5
8	DN200	30.4	13.8	45.6	20.7	2.5	5.7	11.5	5.2
10	DN250	44.1	20.0	69.4	31.5	2.5	5.7	11.5	5.2
12	DN300	75.4	34.2	115.3	52.3	2.5	5.7	22.2	10.1
14	DN350	99.0	44.9	170.4	77.3	—	—	22.2	10.1
16	DN400	121.3	55.0	213.2	96.7	—	—	40.8	18.5
18	DN450	202.8	92.0	262.8	119.2	—	—	40.8	18.5
20	DN500	—	—	—	—	—	—	78.1	35.4
24	DN600	—	—	—	—	—	—	101	45.8



Cv Values Valve Sizing Coefficients (US-GPM/ ΔP)

Size (in)	Disc Position								
	90°	80°	70°	60°	50°	40°	30°	20°	10°
2	132	120	86	58	42	22	11	2	0.1
2½	256	202	142	98	65	37	20	4	0.2
3	505	392	198	125	86	38	21	8	0.3
4	936	702	401	232	140	77	35	14	0.4
5	1109	922	625	392	232	132	62	29	0.9
6	2531	2009	1105	611	372	203	96	42	2.1
8	4812	3555	1901	1211	726	401	191	65	3.2
10	7498	6183	3740	2065	1232	695	321	151	3.9
12	9928	8805	5905	3178	1909	1065	495	234	5
14	12915	10854	7220	4560	2771	1554	712	338	5.8
16	16626	14961	9909	6289	3780	2133	980	460	8
18	23705	19743	13178	8325	5029	2822	1301	613	10
20	27915	25396	16928	10698	6468	3623	1678	790	12
24	43212	39206	26128	16550	9807	5567	2521	860	21

The valve sizing coefficient is referred to as "Cv" and is the rate of water flow in gallons per minute (GPM) through a given opening at a pressure drop (ΔP) of 1 PSI at standard room temperature. The recommended angle of opening for valve sizing is between 50° and 70° open.

Service Factor Rating

Service Condition	Service Type	Media Type	Safety Factor	Multiplier
1	Ideal	Lubricating Oil	20%	1.20
2	Normal	Water	30%	1.30
3	Severe	Dry Air, Solvents	50%	1.50
4	Extreme	Abrasives	100%	2.00

This service factor chart is a suggested guide only. Actual service conditions will vary due to dynamic flow conditions and may require adjustments to the applied safety factor.

Pressure Rating

Size	650/651 SERIES		
	2"-12"	14"-48"	2"-12" (PTFE)
Bidirectional Shutoff	200 PSI	150 PSI	150 PSI

DeltaT 050/051 & 650/651 Butterfly Valves

Seat Material Guide



Seat Material (Backing Material)	Code	General Application	Temperature Range at Full Rated Pressure	Not Recommended For
EPDM (Phenolic)	EPDM	H ₂ O, Air, Brine, Abrasives, Phosphates, Esters Ketones, Alkali, Food Compounds, Liquids and Solids, Dilute Inorganic Acids, Caustic Soda	-40°F to 275°F (-40°C to 135°C)	Hydrocarbons, Oils, Fats, Dry Air
White EPDM Food Grade (Phenolic)	WEF		-40°F to 212°F (-40°C to 100°C)	
Black EPDM Food Grade (Phenolic)	BEF		-40°F to 230°F (-40°C to 110°C)	
High Temp EPDM (Phenolic)	HT-EPDM	Standard EPDM + Low Pressure Saturated Steam	-4°F to 302°F (-20°C to 150°C)	
Wear Resistant EPDM (Phenolic)	WR-EPDM	Standard EPDM + Abrasive Products	14°F to 250°F (-40°C to 121°C)	
BUNA-N (NBR) (Phenolic)	BUNA	Hydrocarbons with less than 40% of aromatics, Natural Gas, Air, H ₂ O, Sea Water, Brine, Alcohols, Glycols	10°F to 180°F (-12°C to 82°C)	Solvents, Benzene, Xylene
White BUNA Food Grade (Phenolic)	WBF		-30°F to 230°F (-30°C to 110°C)	
High Temp BUNA (Hydrogenated NBR) (Phenolic)	HT-BUNA		-30°F to 330°F (-34°C to 165°C)	
VITON (FKM) (Aluminum)	VITON	Hydrocarbons with high concentration of aromatics, Mineral and Halogenated Acids, Phosphoric Acid, Aliphatic and Aromatic Ethers	0°F to 300°F (-18°C to 149°C)	Steam, Ketones, Amines, Esters, Alkali
PTFE over EPDM (Phenolic)	PTFE/E	Corrosive Products - Solvents	-4°F to 275°F (-20°C to 135°C)	Abrasive products, Fluorine Gases, Alkaline Metals
PTFE over VITON (Aluminum)	PTFE/V		-4°F to 300°F (-20°C to 149°C)	

*Material guidelines for reference only. Actual suitability can depend on a combination of temperature, pressure, chemical concentration and other variables.



Seat Material (Backing Material)	Code	General Application	Temperature Range at Full Rated Pressure	Not Recommended For
Natural Rubber (Phenolic)	NR	Abrasive Products	-55°F to 210°F (-48°C to 99°C)	???
Silicone (Phenolic)	SIL	Beverages, Food	-40°F to 400°F (-40°C to 204°C)	Hydrocarbons, Solvents, Steam
Chlorosulfonated Synthetic Rubber (Phenolic)	CSM	Oxidizing Acids, Chromic Acid, Hydrofluoric Acid, Sulphur Based Acids, Sodium Hypochlorite, ozone	0°F to 275°F (-18°C to 135°C)	Steam, Ketones, Hot Air, Nitric Acid
Neoprene (Phenolic)	NP	Oils, Dilute Mineral Acids, Alkali, Fats	20°F to 200°F (-7°C to 93°C)	Ketones, Concentrated Acids, Solvents for Paint

Booted - Poor

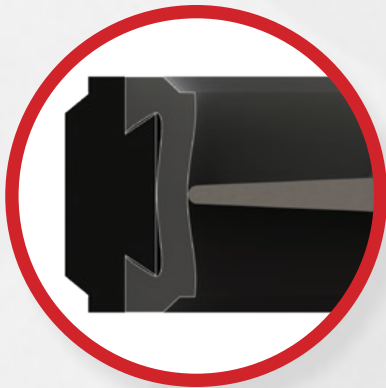

Booted seat bulging around disc contact points

Molded - OK

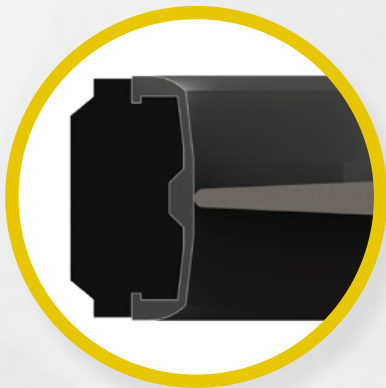

Molded seat permanently bonded to valve body

Superior Cartridge Seat Design Why a DeltaT Cartridge Seat Is the Preferred Choice:

Cartridge - Best

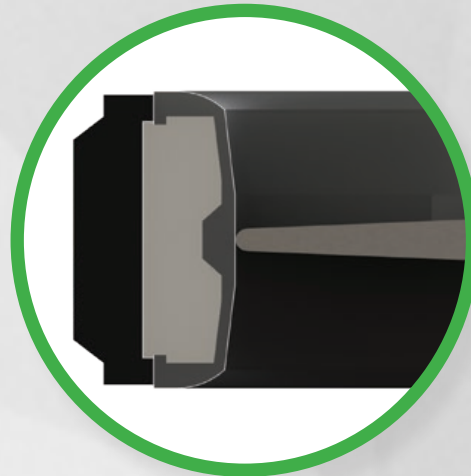

Cartridge seat with rigid phenolic backing ring

Feature	Cartridge Seat	Molded Seat	Booted Seat
Replaceable	YES	NO	YES
Consistent Torque	YES	NO	NO
Ideal for Vacuum Service	YES	YES	NO
Dead End Service Capable	YES	YES	NO
Deformation Resistant	YES	YES	NO
Flange Type Independent	YES	YES	NO

DeltaT 050/051 & 650/651 Butterfly Valves

Disc Material Guide



DI-NP

Nickel Plated Ductile Iron

Ductile iron disc for strength, coated with Nickel Plating for corrosion resistance and increased abrasion resistance.

Recommended Applications:

Air, Kerosene, Oils, Ketones, Hydrocarbons, Solvents, Detergents, Salts, Concentrated Organic Acids

Not Recommended For:

Inorganic Acids, Diluted Organic Acids



CF8M

316 Stainless Steel

Stainless steel disc is inherently strong for industrial use and corrosion resistant for a wide range of chemical and environmental applications.

Recommended Applications:

Acetic Acids, Air, Automotive Oils & Fuels, Beer, Freon, Gasoline, Ketones, Oils, Oxygen, Steam, Sea Water, Potable Water

Not Recommended For:

Acids



AL-BZ

Aluminum Bronze

Strength similar to carbon steel, but with an aluminum oxide layer on the surface for excellent corrosion resistance.

Recommended Applications:

Sea Water, Brine, Detergents, Gasoline, Alcohols, Esters, Ketones, Potable Water

Not Recommended For:

Acids

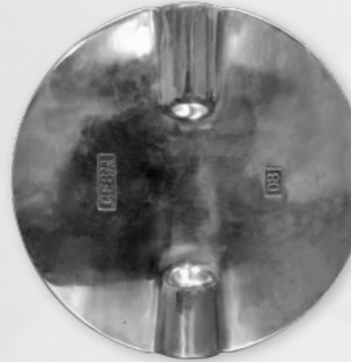

Polished

Polished 316 Stainless Steel

All the benefits of stainless steel strength and corrosion resistance, plus a highly polished surface for sanitary applications.

Recommended Applications:

Sanitary Applications, Potable Water

Not Recommended For:

Acids

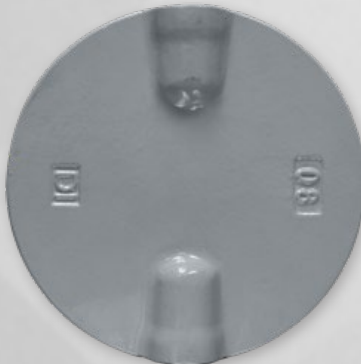

NY11

Nylon 11 Coated Ductile Iron

Ductile iron disc for strength, coated with Nylon 11 for corrosion resistance and excellent abrasion resistance.

Recommended Applications:

Inorganic Salts, Alkalis, Most Solvents, Most Organic Acids, Hydrocarbons, Oils, Kerosene, Ketones, Esters, Detergents, Sea Water, Abrasives

Not Recommended For:

Inorganic Acids, Phenols, Chlorinated Solvents



PTFE

PTFE Coated 316 Stainless Steel

Recommended Applications:

Acids, Alcohols, Solvents, Oils, Potable Water

Not Recommended For:

Fluorine

**Material guidelines for reference only. Actual suitability can depend on a combination of temperature, pressure, chemical concentration and other variables.*

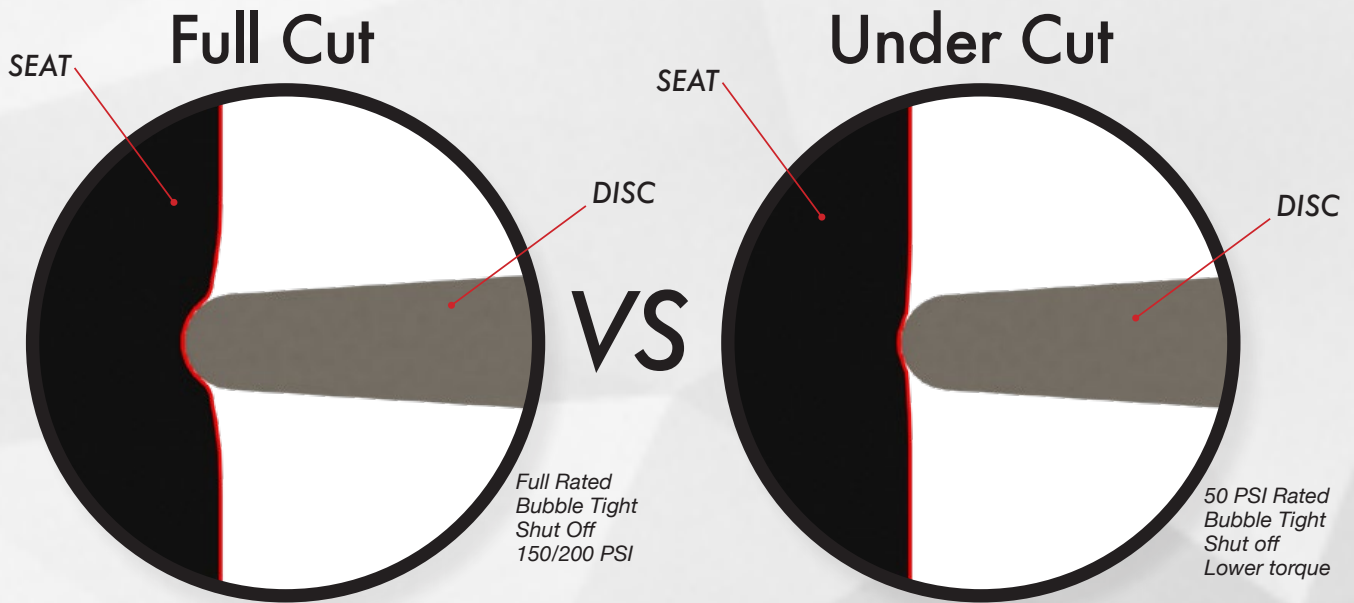

Why Full Cut?

Full cut discs provide bubble tight shut off at 150/200 PSI for a wide variety of applications, such as liquid or gas media.

Why Under Cut?

Under cut discs require less torque to operate but are only rated to 50 PSI bubble tight shutoff. common applications are solids dispensing or conveying, or any low pressure process.

Valve & Disc Treatment Options



Passivation

Why passivation treatment?

Passivation is a process by which the inherent corrosion resistance of stainless steel is maximized through a two step process of cleaning and subsequent immersion in an acid bath thereby creating a uniform oxidation layer that optimizes the corrosion resistance.

What's treated?

Disc only



Silicone Free

Why silicone free treatment?

Silicone Free cleaning is conducted on valves in order to prevent silicone contamination within processes (such as automotive painting) that are sensitive to silicone. The valves are subsequently sealed within polyethylene bags to prevent recontamination prior to installation.

What's treated?

Total Valve



Oxygen Clean

Why oxygen clean treatment?

Oxygen cleaning is conducted on valves to prevent the potentially violent oxidation (fire or explosion) of contaminants (most often hydrocarbons) on the surfaces exposed to oxygen within a process. The valves are subsequently sealed within polyethylene bags to prevent recontamination prior to installation.

What's treated?

Total Valve

Slim Disc Design

What is the advantage of the Slim Disc design?

Delta T's slim disc design minimizes the disc profile to maximize flow. This is especially important for smaller butterfly valves where the disc takes up proportionally more of the flow path. Slim disc design is standard up to 12" sizes.

Standard Disc Design
14" and up

Slim Disc High Cv Design
Up to 12"



Crossover Guide

Body	Ductile Iron						Valve Type
	Ductile Iron-Nickel Plated		Aluminum-Bronze		316 Stainless Steel		
Disc	Ductile Iron-Nickel Plated		Aluminum-Bronze		316 Stainless Steel		
Seat	EPDM	BUNA	EPDM	BUNA	EPDM	BUNA	
	050-262	050-263	050-780	050-783	050-579	050-582	Wafer
	051-262	051-263	051-780	051-783	051-579	051-582	Lug
Bray	30-11010-119	30-11010-713	30-11010-120	30-11010-684	30-11010-124	30-11010-125	Wafer
	31-11010-119	31-11010-713	31-11010-120	31-11010-684	31-11010-124	31-11010-125	Lug
Centerline	A2-021-05	A2-021-01	A2-061-05	A2-061-01	A2-044-05	A2-044-01	Wafer
	B2-021-05	B2-021-01	B2-061-05	B2-061-01	B2-044-05	B2-044-01	Lug
Demco	NE-C111535_	NE-C111531_	NE-C111435_	NE-C111431_	NE-C112235_	NE-C112231_	Wafer
	NE-C511535_	NE-C511531_	NE-C511435_	NE-C511431_	NE-C512235_	NE-C512231_	Lug
Grinnell	WD-820_-3	WD-810_-3	WD-828_-3	WD-818_-3	WD-827_-4	WD-817_-4	Wafer
	LD-820_-3	LD-810_-3	LD-828_-3	LD-818_-3	LD-827_-4	LD-817_-4	Lug
Keystone	AR1-323	AR1-285	AR1-061	AR1-064	AR1-805	AR1-723	Wafer
	AR2-323	AR2-285	AR2-061	AR2-064	AR2-805	AR2-723	Lug
Kitz	5112E	5112B	5122E	5122B	5141E	5141B	Wafer
	6112E	6112B	6122E	6122B	6141E	6141B	Lug
Mueller Steam	SERIES 51	SERIES 51	87-INB6	87-INB3	87-INH6	87-INH3	Wafer
	SERIES 52	SERIES 52	88-INB6	88-INB3	88-INH6	88-INH3	Lug
NIBCO	WD-2010	WD-2110	WD-2000	WD-2100	WD-3022	WD-3122	Wafer
	LD-2010	LD-2110	LD-2000	LD-2100	LD-3022	LD-3122	Lug



Handles & Throttle Plates

Delta T butterfly valves can be readily equipped with lever handles for easy manual operation, which come standard with a 10 position notch plate for quick open/close and throttling. Ductile iron valves are available with malleable iron handles and standard plated carbon steel notch plate. Stainless steel valves are available with 304 SS handles and matching 304 SS notch plates. Lever handles and notch plates are available up through 12" sizes. See pages 9 & 19 for more handle details.

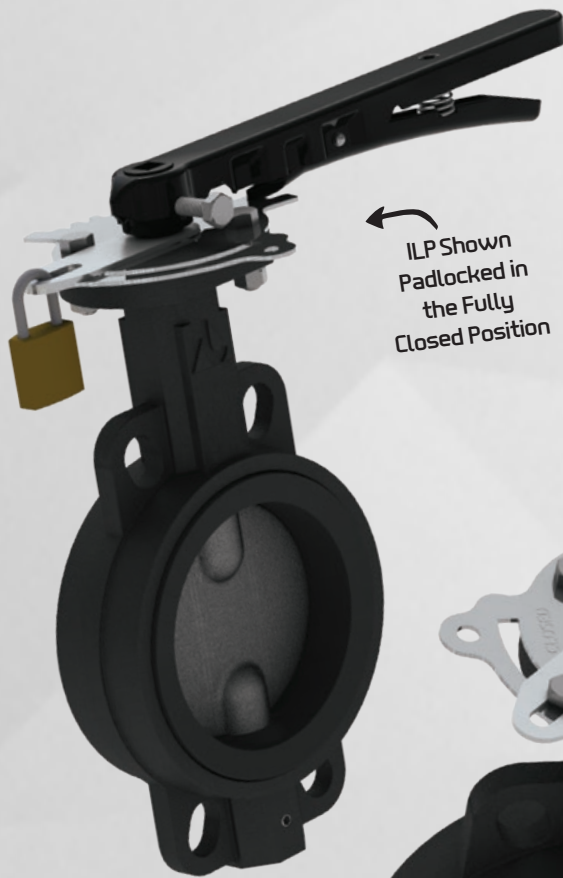
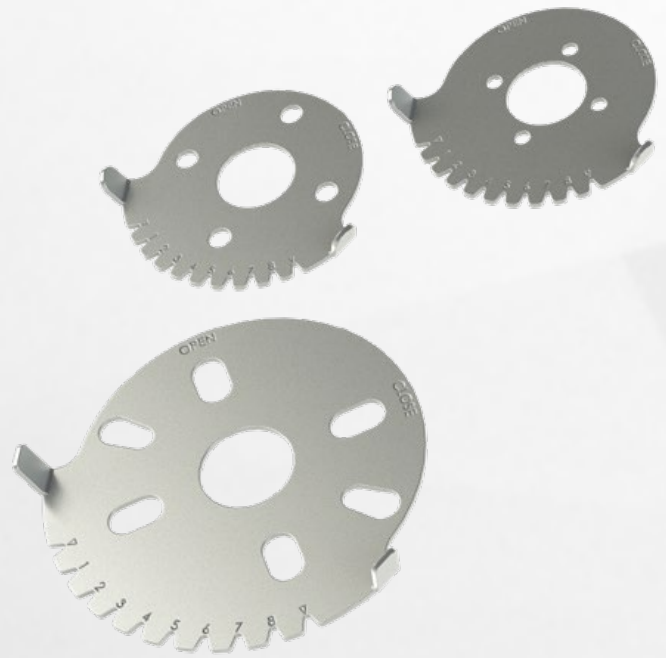

ILP Shown
Padlocked in
the Fully
Closed Position



ILP Shown
Bolted in an
Intermediate
Position

Infinite Locking Plates & Arms

For more adjustable throttling and lockout capability on lever handle operated valves, Delta T "ILP" series infinite locking plates are designed to directly replace the standard notch plates. ILP kits come with a 304 SS base plate and arm to allow throttling positions at any angle and lockout at full open or closed. Delta T infinite locking plates can be used on either ductile iron or stainless steel butterfly valves up through 12" sizes. See pages 8 & 18 for more details.

Manual Gear Operators

All butterfly valve sizes can be outfitted with a manual gear operator for low-torque operation. Delta T's GO Series gear operators are made to direct mount to keep a low profile and simplify installation. Epoxy coated ductile iron housings and malleable iron hand wheels make these gear operators very robust for industrial applications. Chain wheels can be furnished upon request. See pages 9 & 19 for more details.

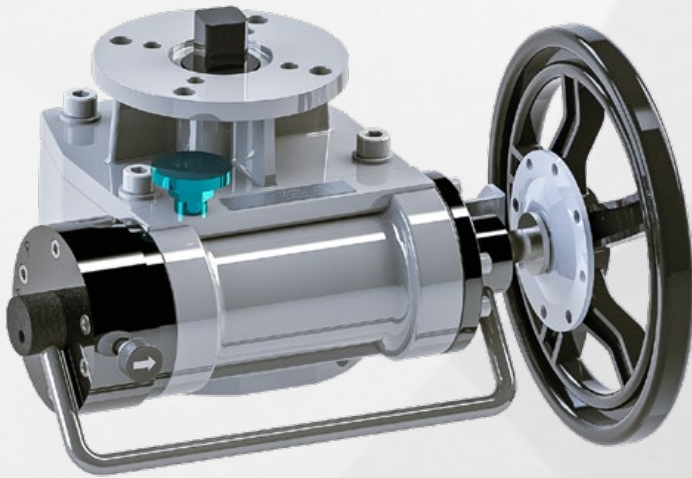

Declutch-able Gear Operators

For automated butterfly valves, declutch-able sandwich style gear operators allow for hand wheel operated manual override for maintenance or emergency situations. PV01 series declutch-able gear operators direct mount to ISO 5211 standard actuators and to all Delta T butterfly valves. Contact factory for more details.

Lockout Devices

All Delta T butterfly valves can be equipped with lockout devices, either handle operated or gear operated. Lockout kits come in plated carbon steel or 304 SS. Contact factory for more details.



Installation Guidelines

Please Contact Factory for Full Installation and Operation Manual

Figure 2

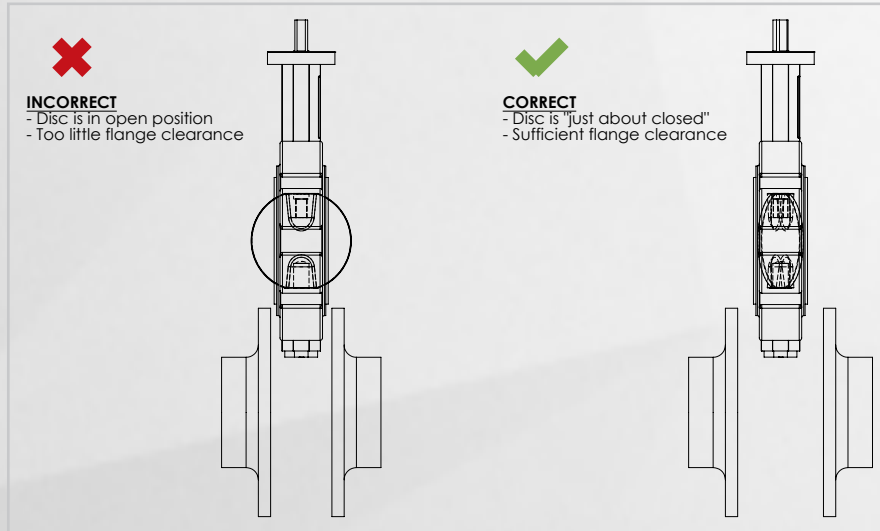

Bolting Requirements:

The required bolting information is listed on page 61 (see Table 1), and is designed to provide information regarding size, type, and quantity of bolting recommended for installation of the Delta T Series resilient seated butterfly valves. All recommendations are in accordance with ASME 125/150 specifications. Please note flange bolting is not included with shipment of any valve.



NOTE: For schedule 10 and/or thin wall pipe, extra care must be taken to align seat on flange face to avoid valve damage.

Pre-installation Checklist:

1. Remove any protective flange covers from the valve
2. Inspect the valve to ensure the flow path is free from dirt and debris
3. Be careful that the mating pipeline is also free from dirt and debris, such as rust, pipe scale, welding slag and debris, which can easily damage the seat and disc surfaces
4. Any operators, either manual or automated, should be installed PRIOR to installation, to ensure proper alignment of all connecting hardware, and also proper alignment of the disc and valve seat
5. Double check the valve identification tag to ensure that the valve materials meet the intended operating conditions. It is always critically important to double check all factors during the installation process

Valve Alignment and Flanging:

Do not install flange gaskets – the butterfly valve seat is designed to mate directly to the flange and provides the seal. Leave the disc in the “just about closed” position and center the disc with the pipeline (See Figure 3 on the right). The next step is to insert all necessary bolts to attach the valve to the flanges, which varies depending on wafer or lug style.

For wafer style valves, loosely install the four bolts that pass through the upper and lower body alignment holes as shown in Figure 4 on the right. Next, insert the remaining flange bolts until all bolts are in position, then hand tighten all bolts. For lug valves, loosely install all bolts between the flanges and the lugs and hand tighten when complete if using style C as shown in Figure 4. If using lug style B, first insert threaded studs, then hand tighten the nuts on each side.

Before tightening the bolts, the valve needs to be positioned so that disc movement is free and unobstructed. Carefully open the disc to the fully open position and verify that there is no interference between the disc and the flanges. In addition, ensure that the flanges are properly aligned during tightening to minimize uneven stress or damage on the valve body or seat (See Figure 5 on the right). It is recommended to follow the Bolt Tightening Procedure on the next page.

WARNING: PERSONAL INJURY OR PROPERTY DAMAGE MAY RESULT IF THE VALVE IS INSTALLED WHERE SERVICE CONDITIONS EXCEED VALVE RATINGS. PLEASE TAKE SPECIAL CARE TO DOUBLE CHECK ALL FACTORS DURING THE INSTALLATION PROCESS.

Initial Valve Positioning:

Before valve installation, it is important to properly align the mating pipe flanges. To install the valve, create enough space between the two flanges so that the valve body will fit without contact and carefully move the valve into position. Make sure the valve disc is in the “just about closed” position before insertion (See Figure 2 on the right).

Figure 3

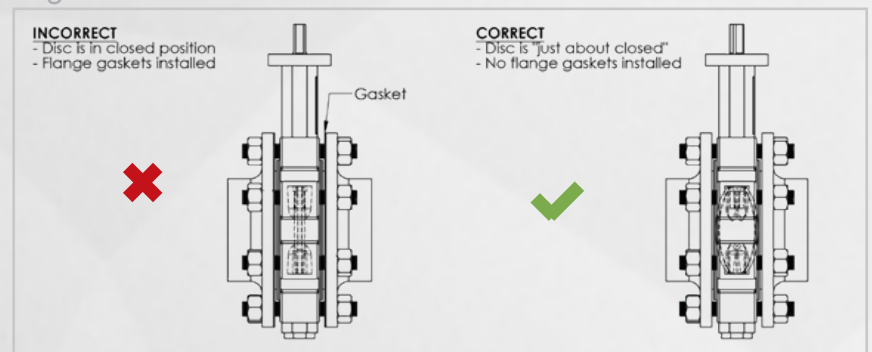

Figure 4

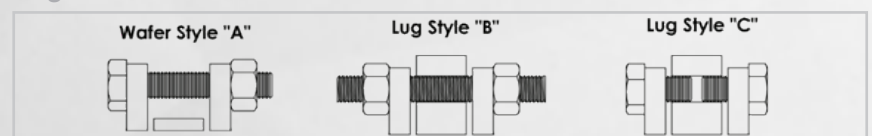
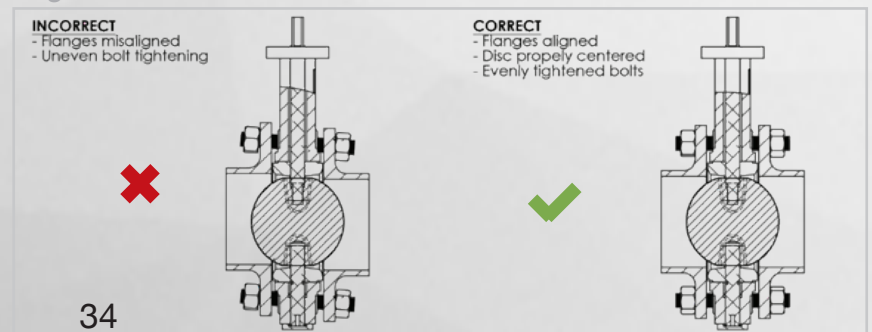

Figure 5



Bolt Tightening Sequence:

For lugged style valves (particularly important for PTFE seated valves), it is essential to tighten the flange bolting uniformly on both sides of the valve to assure that the cartridge seat is not forced out of position. Improper tightening can result in leakage through the stem seals. The proper tightening procedure is as follows (See Figure 6 on the right):

1. If using a long stud and nuts as in style "B", after positioning the valve between the mating flanges, install the nuts in all positions to hand tight or just until they contact the flange face only. If using bolts as in style "C", tighten the bolts on both sides of the valve until they are hand tight or just contacting the flange face.
2. The nuts or bolts immediately on either side of the upper stem (position 1 & 2) should be tightened first. Start with position 1 and tighten bolts/nuts in 1/2 turn increments, alternating between the front and back flanges.
3. Once that position is tight, proceed to tighten the bolt/nut pair opposite from the pair that was just tightened and tighten in the same fashion (position 2).
4. Follow the same sequence as in steps 2 and 3 above on the opposite end of the valve near the lower stem (positions 3 & 4).
5. Tighten the remaining bolts (if any) in a star pattern around the valve and then re-check all bolts/nuts for tightness in a star pattern for all bolts/nuts (position 5, 6, 7, 8, etc). Make sure to alternate sides and tighten in 1/2 turn increments.

Caution:

Note that resilient seated butterfly valves are designed around the ID for schedule 40 pipe as it is the most common wall thickness utilized. As such, there are some cautions that users must be aware of when utilizing thinner wall or heavier wall pipe. These can also apply to the use of special face rings and van stone flanges.

1. When installed with thin wall pipe, schedule 10 or lighter (common in SS pipe applications), the alignment of the valve against the flange face becomes critical. As the pipe has a larger ID than the valve, there is less gasketing surface available so the valve **MUST** be very accurately centered with the flanges on both sides. If it is not, leakage at the flange faces or through the stem bores could occur. Face rings can make this situation worse as they frequently have a radius or bevel at the face to pipe transition.
2. When installed with heavy wall pipe, most common with plastic piping systems, the ID of the pipe should be checked against the "Q" dimension of the butterfly valve. If the Q dimension is larger than the pipe ID or very close, beveled adapters may be required for the valve to be able to fully open.

Figure 6

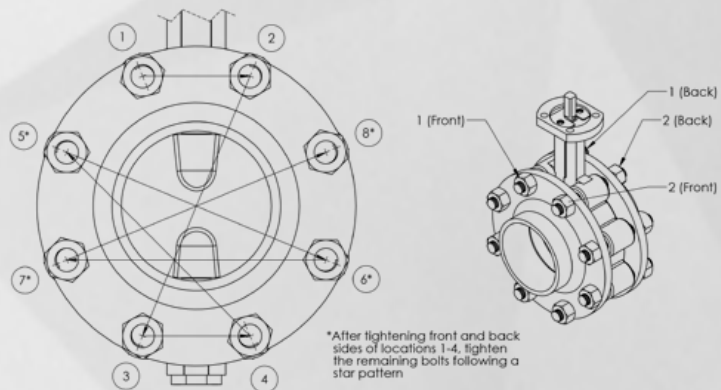

Flange Bolting Requirements:

Valve Size	Diameter	Machine & Stud #	Cap Screw #	Bolt Length A	Stud Length B	Cap Screw Length C	Thread Size	Recommended Torque in-lbs
1.5"	0.500	4	8	3.25	3.75	1.25	1/2"-13UNC	25-30
2"	0.625	4	8	4.00	5.00	1.25	5/8"-11UNC	30-35
2.5"	0.625	4	8	4.25	5.25	1.50	5/8"-11UNC	30-35
3"	0.625	4	8	4.50	5.25	1.50	5/8"-11UNC	35-40
4"	0.625	8	16	5.00	6.00	1.75	5/8"-11UNC	35-40
5"	0.750	8	16	5.50	6.50	1.75	3/4"-10-UNC	35-50
6"	0.750	8	16	5.50	6.75	2.00	3/4"-10UNC	35-65
8"	0.750	8	16	6.00	7.00	2.25	3/4"-10UNC	45-80
10"	0.875	12	24	6.75	8.00	2.25	7/8"-9UNC	55-100
12"	0.875	12	24	7.00	8.25	2.50	7/8"-9UNC	65-120
14"	1.000	12	24	7.75	9.00	2.75	1"-8UNC	75-130
16"	1.000	16	32	8.00	9.00	3.25	1"-8UNC	75-140
18"	1.125	16	32	8.75	10.00	3.50	1-1/8"-7UNC	85-170
20"	1.125	20	40	9.50	10.75	3.75	1-1/8"-7UNC	85-180
24"	1.250	20	40	10.25	12.50	4.50	1-1/4"-7UNC	100-220



NOTE: These torque values are a general recommendation ONLY for minimum tightening torques. Many factors affect tightening requirements including bolt grade, pipe alignment, flange material and others. Field engineering personnel must make final torque value decisions. Call factory for flange bolting requirements up to 48" size.



*QR Code
for Website

THE BRAND
BY WHICH
ALL OTHERS ARE
MEASURED

